

Fig.	Part No.	Qty. Used	Description	Fig.	Part No.	Qty. Used	Description
1	211087-9	1	B. BEARING 6200DDW	30	911223-4	4	P.H. SCREW M5x16
2	681630-2	1	INS. WASHER 10	31	159469-6	1	GEAR HOUSING CPL.(INCL. N. BEARING 1012: 212063-6; SLEEVE: 322513-4)
3	639501-7	1	FIELD	32	*	1	MOTOR HOUSING ASSY.(INCL. SUPPORT UNIT: 632282-2; BRUSH HOLDER: 643705-5)
4	*	1	BAFFLE PLATE	35	911691-1	2	P.H. SCREW M5x70
5	518487-7	1	ARMATURE ASSY. 115V (INCL. FIG. 1 & 2)	36	182607-5	1	HANDLE SET
7	285672-4	1	BEARING RETAINER 57	37	265016-4	1	P.H. SCREW M6x85
8	211132-0	1	B. BEARING 6301DDW	38	911148-2	4	P.H. SCREW M4x25
9	226715-3	1	SPIRAL BEVEL GEAR 12	39	664463-0	1	CORD (2x14x8 SJ)
10	961005-4	1	RETAINING RING S-9	40	682505-8	1	CORD GUARD 10
11	911263-2	4	P.H. SCREW M5x40	41	687052-4	1	STRAIN RELIEF
12	421421-7	1	TOOL REST	42	265995-6	2	TAPPING SCREW 4x18
13	414990-5	1	PIN CAP	43	651143-7	1	SWITCH
14	233031-6	1	COMP. SPRING 12	46	191957-7	1	CARBON BRUSH SET CB-204
15	265977-8	1	BOLT M5x20	47	643700-5	2	BRUSH CAP (CB-200)
16	256431-3	1	PIN 6	ACCESSORIES			
17	152492-0	1	SIDE HANDLE 37	400	741413-3	1	7" GRINDING WHEEL # 24
18	265976-0	1	BOLT M5x10	401	782412-6	1	LOCK NUT WRENCH 28
19	961057-5	1	RETAINING RING S-17	402	224317-9	1	INNER FLANGE 89
20	226714-5	1	SPIRAL BEVEL GEAR 50	403	192568-1	1	LOCK NUT 45
21	962157-4	1	RETAINING RING R-40	404	192413-0	1	7" WHEEL COVER
22	211278-2	1	B. BEARING 6203DDW				
23	316399-6	1	BEARING BOX				
24	322724-1	1	SPINDLE				
25	251383-3	1	P.H. SCREW M8x30				
29	254001-2	1	WOODRUFF KEY 4				

* SEE SERVICE CHANGE 1

SERVICE CHANGE

1. Change on Motor Housing from S/N 5,009,293.

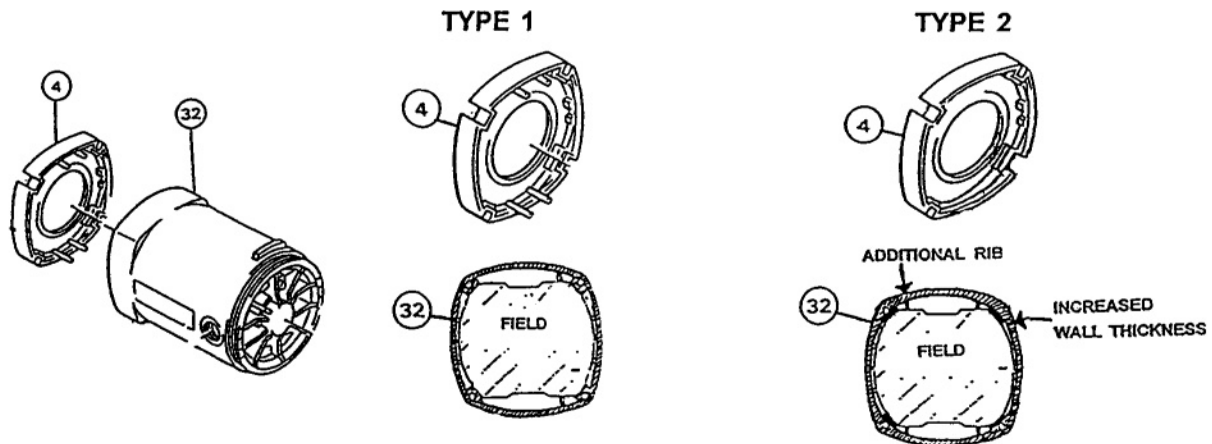

FIG.	DESCRIPTION	TYPE 1	TYPE 2
4	Baffle Plate	Part # 414989-0	Part # 415647-1
32	Motor Housing	Part # 125029-6 (Discontinued)	Part # 125036-9

The above parts are interchangeable as a set.