

Type: JMU 137-2 QW (60Hz, 120V)
Part no.: 72705812110

Item	Part no.	Designation	Quantity	Unit
20	51282002110	Stator 60Hz/110V	1	9
40	31428196000	Air guide ring	1	9
50	53281007110	Armature 50/60H110/120V	1	9
60	41701001172	Grooved ball bearing	2	9
62	41701001260	Grooved ball bearing	1	9
70	32172014010	Magnet	1	9
80	32416098005	Plate	1	9
90	41701207260	Grooved ball bearing	1	9
100	32612135000	Sealing ring	1	9
110	42639028003	Sealing ring	1	9
125	32411089000	Cover	1	9
135	30711160000	Carbon brush 110-120V, 50/60Hz	2	9
140	43072000000	Screw	2	9
150	32427157000	Cover	2	9
160	30762562990	Electronics	1	9
185	31901204070	Motor housing U 120V	1	9
191	31414072000	Protective hose	1	9
192	32429146010	Connecting piece	1	9
193	30719936010	Connecting cable	1	9
195	32217468060	Sticker	1	9
196	30719943010	Cable harness	1	9
200	30728445000	Terminal	2	9
210	30762560990	Electronics	1	9
220	32816078000	Switch insert	1	9

Type: JMU 137-2 QW (60Hz, 120V)
Part no.: 72705812110

Item	Part no.	Designation	Quantity
230	32429141000	Cover	1
250	31506412010	Intermediate gear box	1
260	41701006034	Grooved ball bearing	1
270	41701202018	Grooved ball bearing	2
290	43072006001	Screw	4
295	31508312020	Gearbox housing	1
310	40242058004	Pin	2
340	41701000015	Grooved ball bearing	1
350	42616014009	Circlip	1
360	40608000005	sealing ring	2
370	42644019001	Circlip	1
385	33403131000	Shaft	1
395	30216174000	Roller	6
397	30109230010	Draw key Set	1
400	33663177000	Gear-wheel Z=39	1
405	32408435000	Disc	3
410	42643011006	Circlip	2
420	33763064000	Shaft, toothed Z=17	1
430	33661003000	Wheel	1
440	33661002000	Gear-wheel Z=36	1
455	30504112010	Sleeve	1
470	33761002000	Shaft, toothed	1
480	33657190000	Gear-wheel	1
490	40612125002	Sealing ring	1

Type: JMU 137-2 QW (60Hz, 120V)
Part no.: 72705812110

Item	Part no.	Designation	Quantity
500	32805233020	Switch pushbutton	1
520	30235024000	Plate	1
525	30216154000	Pin	1
530	30610048000	Seal	1
550	41138025006	Hose socket	1
560	33218134000	Pressure piece	1
570	32170025000	Lever	2
580	30901404000	Spring	1
590	30216154010	Plunger	1
600	32408389000	Disc	1
615	42616033009	Circlip	1
625	30240330000	Pin	2
635	30501371000	Clamping sleeve	1
645	30501373000	Bush	1
655	30901401000	Spring	1
665	30501372000	Sleeve	1
670	42616076000	Circlip 28X1,5	1
705	31207320020	Housing	1
720	31602089009	Bush	2
730	30904047000	Leaf spring	1
740	43076001030	Screw	1
750	33216047000	Pressure piece	1
760	34300000002	Guide strip	2
770	43035076041	Cylinder head screw	10

Type: JMU 137-2 QW (60Hz, 120V)
Part no.: 72705812110

Item	Part no.	Designation	Quantity
775	30229350010	Shift fork	1
780	43058008051	Set screw	5
790	33812007004	Gear rack	1
810	43035017057	Cylinder head screw	2
820	34300000003	Guide	1
830	43041041053	Fillister head screw	2
840	33713073000	Shaft, toothed	1
850	42446003009	Disc	1
860	42616065008	Circlip	1
870	30109201010	Connecting piece	1
890	32119114014	Handle	3
900	32636046000	Scale	1
910	43035084062	Cylinder head screw	1
920	40612171000	Sealing ring	1
926	30701223005	Button	1
927	30701224003	Cap	1
930	32424036000	Cover	1
935	30719935010	Connecting cable	1
940	31413237000	Protective hose	1
950	30707528010	Cable with plug	1
960	32431043002	Cable clamping piece	1
970	43074010000	Screw	2
980	32424031000	Cover	1
990	30762561990	Electronics 110-230V 50/60Hz	1

Type: JMU 137-2 QW (60Hz, 120V)
Part no.: 72705812110

Item	Part no.	Designation	Quantity
1000	43074013000	Screw	3
1030	43064024043	Screw	2
1040	32424037000	Cover	1
1050	43074008000	Screw	11
1060	43035013058	Cylinder head screw	2
1070	43033064066	Cylinder head screw	4
1080	32172031000	Magnetic foot	1
1090	32132035010	Container	1
1091	40612112007	Sealing ring	1
1092	40612087004	Sealing ring	1
1095	30240357010	Ball cock Set	1
1096	31414070010	Flex-jointed hose	1
1100	31414073000	Hose	1
1105	30501377000	Sleeve	1
1110	42015000000	Nut	1
1260	32217513000	Information sign	1
1270	32217406002	Sticker	1
1275	32217552000	Information sign	1
1290	32217465060	Information sign	1
1310	32217466060	Information sign	1
2500	32217517000	RFID Transponder VE1	1
5000	33901175040	Tool box ass.	1
5010	30232052000	Wire clamp	2
5020	33904576000	Insert	1

Type: JMU 137-2 QW (60Hz, 120V)
Part no.: 72705812110

Item	Part no.	Designation	Quantity
5100	31810298000	Protective grille	1
5110	63134998310	Centering pin	1
5120	64201001000	Hook f. chip removal	1
5130	32174008007	STRAP, SAFETY	1
5150	63134998300	Centering pin	1
5170	30217338000	Centering pin	1
6000	32132041000	Lubricant can 1000 g	1

Type:
Part no.:

JMU 137-2 QW (60Hz, 120V)
72705812110

7 270 58 - JMU137-2QW

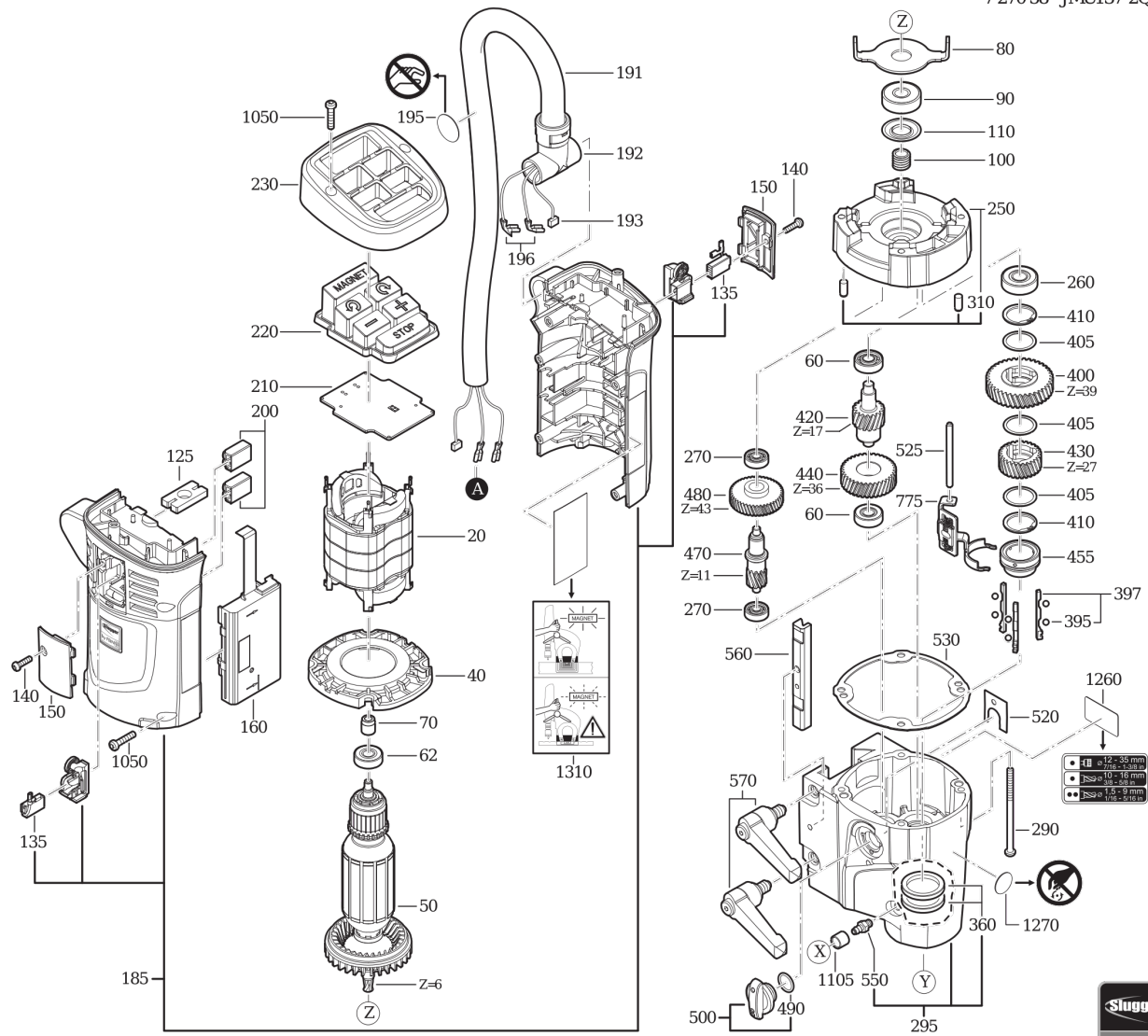

Type:
Part no.:

JMU 137-2 QW (60Hz, 120V)
72705812110

7 270 58 - JMU137-2QW

