

16.1.1 Motor and Trunnion – Exploded View

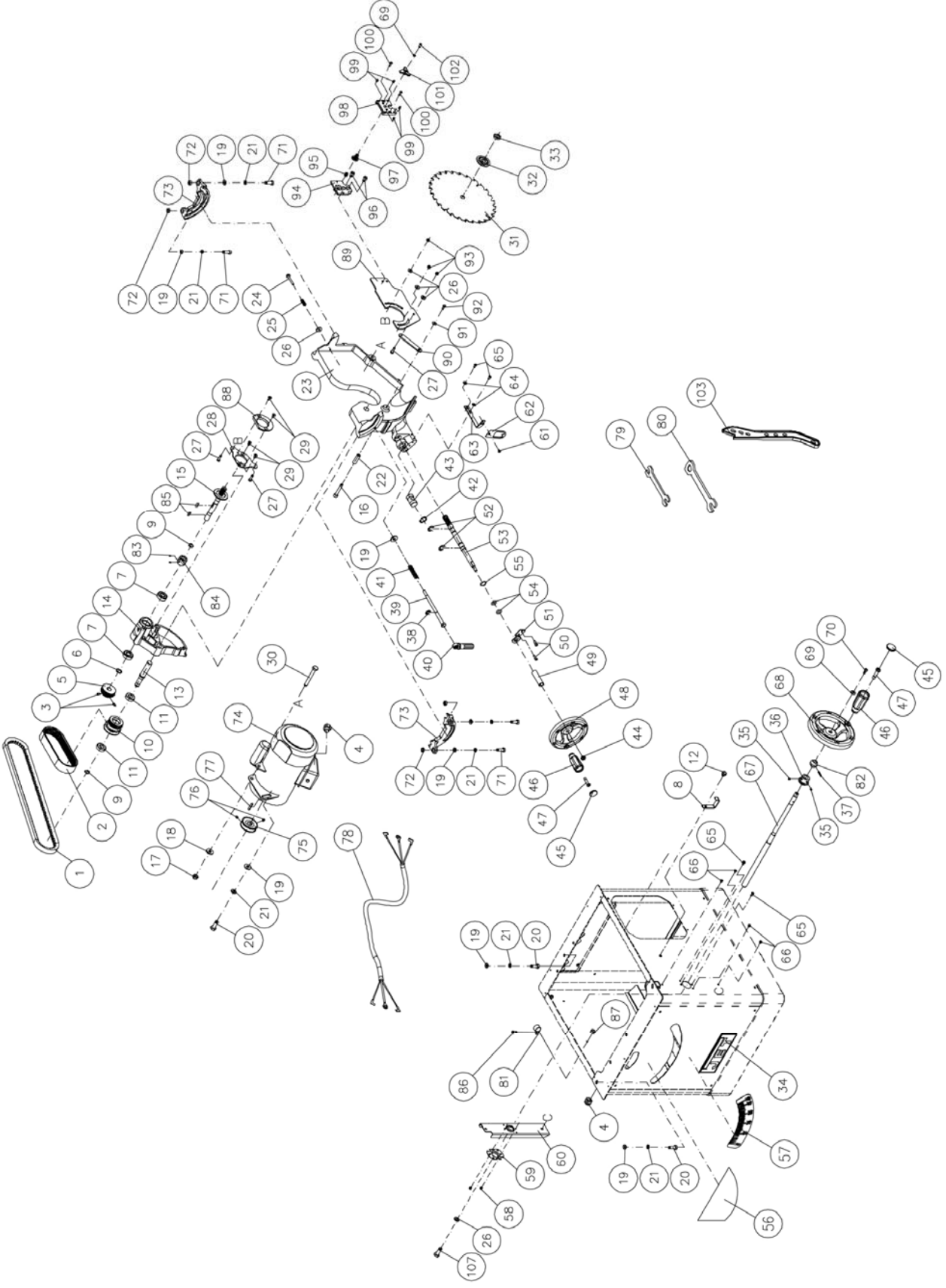

16.1.2 Motor and Trunnion – Parts List

Index No	Part No	Description	Size	Qty
1	VB-A31	V-Belt	A-31	1
2	JPS10TSR-102	Belt	125J-6	1
3	TS-1523031	Socket Set Screw	M6 -1.0Px10	2
4	JPS10TS-351	Strain Relief	SB8R-3	2
5	JPS10TSR-105	Pulley		1
6	JPS10TSR-106	Washer		1
7	BB-6202VV	Ball Bearing	6202-2NSE	2
8	JPS10TSR-108	Hook		1
9	JWTS10-109	Retaining Ring, External	STW-15	2
10	JPS10TSR-110	Pulley		1
11	BB-6002VV	Ball Bearing	6002-2NSE	2
12	TS-1490011	Hex Cap Screw	M8-1.25Px12	1
13	JPS10TSR-113	Shaft		1
14	JPS10TSR-114	Bearing Arm		1
15	JPS10TSR-115	Arbor		1
16	TS-1504101	Socket Head Cap Screw	M8-1.25Px50	1
17	TS-1541041	Nylon Lock Hex Nut	M10	1
18	TS-1550071	Flat Washer	M10	1
19	TS-1550061	Flat Washer	M8	9
20	TS-1504041	Hex Cap Screw	M8-1.25Px20	4
21	TS-2361081	Lock Washer	M8	8
22	JPS10TSR-122	Bushing		1
23	JPS10TSR-123	Center Trunnion		1
24	JWTS10-124	Hex Flange Bolt	M6x40	1
25	JWTS10-125	Spring		1
26	TS-1550041	Flat Washer	M6	6
27	TS-1482041	Hex Cap Screw	M6-1.0Px20	3
28	JPS10TSR-128	Fixing Plate		1
29	TS-2286121	Phillips Flat Head Machine Screw	M6-1.0Px12	4
30	TS-2210801	Hex Cap Screw	M10x80	1
31	JPS10TSR-131	Blade	10"x5/8"x40T	1
32	JWTS10-132	Flange		1
33	JWTS10-133	Arbor Nut	5/8"-12	1
34	JETLOGO-1	JET Logo Plate		1
35	TS-1522011	Socket Set Screw	M5x6	2
36	JPS10TS-136	Fixing Ring		1
37	JPS10TS-137	Spring Pin	Ø4x18	1
38	JWTS10-138	E-Clip	ETW-8	1
39	JPS10TSR-139	Bolt		1
40	JWTS10-140	Handle		1
41	JWTS10-141	Spring		1
42	JPS10TSR-141	Retaining Ring	RTW-24	1
43	JWTS10-143	Guide Shaft		1
44	JPS10-144	Knob		1
	JPS10TS-FHA	Front Hand Wheel Assembly (#45 thru #48)		1
45	JWTS10-145	Handle Cap		2
46	JWTS10-146	Handle		2
47	JWTS10-147	Shaft		2
48	JPS10TS-148	Hand Wheel		1
49	JPS10TSR-149	Bushing		1
50	TS-1502031	Socket Head Cap Screw	M5x12	3
51	JWTS10-151	Plate		1
52	JWTS10-152	E-Clip	ETW-12	2
53	JPS10TSR-153	Shaft		1
54	JWTS10-154	O-Ring	P12	2

Index No	Part No	Description	Size	Qty
55	JWTS10-155	Wave Washer	WW-16	1
56	LM000636	Warning Label		1
57	JPS10TSR-157	Angle Scale		1
58	TS-1541011	Nylon Lock Hex Nut	M5	2
59	JWTS10-159	Collar		1
60	JPS10TSR-160	Support Bracket		1
61	TS-2284082	Phillips Pan Head Machine Screw	M4x8	1
62	JPS10TS-162	Pointer		1
63	JPS10TSR-163	Bracket		1
64	TS-1550031	Flat Washer	M5	2
65	TS-1533042	Phillips Pan Head Machine Screw	M5x12	4
66	990805	Self Tapping Screw	M4x10	4
67	JPS10TS-167	Shaft		1
	JPS10TS-SHA	Side Hand Wheel Assembly (#68, #45 thru #47)		1
68	JPS10TS-168	Hand Wheel		1
69	TS-1551031	Lock Washer	M5	2
70	TS-1502031	Socket Head Cap Screw	M5x12	2
71	TS-1490041	Hex Cap Screw	M8x25	4
72	TS-1540061	Hex Nut	M8	4
73	JPS10TSR-173	Front & Rear Trunnion		2
74	JPS10TSR-174	Motor	1-3/4HP, 1Ph, 115/230V	1
	JPS10TSR -174MF	Motor Fan (not shown)		1
	JPS10TSR-174MFC	Motor Fan Cover (not shown)		1
	JPS10TSR -174CS	Centrifugal Switch (not shown)		1
	JPS10TSR -174SCC	Starting Capacitor Cover (not shown)		1
	JPS10TSR-174RCC	Running Capacitor Cover (not shown)		1
	JPS10TSR-174SC	Starting Capacitor (not shown)	200MFD, 125VAC	1
	JPS10TSR-174RC	Running Capacitor (not shown)	35µF, 300VAC	1
	JPS10TSR-174JB	Junction Box (not shown)		1
	JPS10TSR-174JBC	Junction Box Cover (not shown)		1
	JPS10TS-174OL	Overload		1
	JPS10TSR-174DC	Dust Cover		1
75	JPS10TSR-175	Pulley		1
76	TS-1523041	Socket Set Screw	M6x12	2
77	JPS10TSR-177	Key	5x5x22	1
78	JPS10TSR-178	Motor Wire		1
79	JBOS5-106	Open end Wrench	#10 - #12	1
80	JPS10TSR-180	Blade Open End Wrench	#23	1
81	JPS10TS-181	Motor Cord Clamp		2
82	JPS10TS-182	Turning Ball		1
83	TS-1521011	Socket Set Screw	M4x4	2
84	JPS10TS-184	Stop Collar		1
85	JPS10TS-185	Key	5x5x18	2
86	TS-1532042	Phillips Pan Head Machine Screw	M4x12	2
87	TS-1540021	Hex Nut	M4	3
88	JPS10TSR-188	Plate		1
89	JPS10TSR-189	Extension Plate		1
90	JPS10TSR-190	Bar		1
91	JPS10TSR-191	Washer		1
92	TS-1481031	Hex Cap Screw	M5-0.8x12	1
93	TS-1541021	Nylon Lock Hex Nut	M6-1.0P	3
94	JPS10TSR-194	Riving Knife Clamp Base		1
95	JPS10TSR-195	Spring		1
96	TS-1504021	Socket Head Cap Screw	M8-1.25Px12	2
97	JPS10TSR-197	Bolt		1
98	JPS10TSR-198	Riving Knife Clamp Plate		1
99	JPS10TSR-199	Nylon Set Screw	M6-1.0Px8	4
100	TS-1533052	Phillips Pan Head Machine Screw	M5-0.8Px16	2
101	JPS10TSR-101	Lock Knob		1

Index No	Part No	Description	Size	Qty
102	TS-2245122	Socket Head Button Screw	M5-0.8Px12	1
103	JPS10TSR-103	Push Block		1
104	JPS10TSR-104	Open End Wrench (not shown)	#11 - #13	1
105	JPS10TSR-105	Angle Wrench (not shown)	2.5mm	1
106	TS-152705	Angle Wrench (not shown)	4mm	1
107	JPS10TSR-107	Nylon Socket Head Cap Screw	M6x15	1
	STRIPE-1-3/4	JET Stripe (not shown)	1-3/4" w.	per ft.
	JPS10TSR-HP	Hardware Package (see section 8.1 for included items)		1

16.2.1 Table and Cabinet – Exploded View

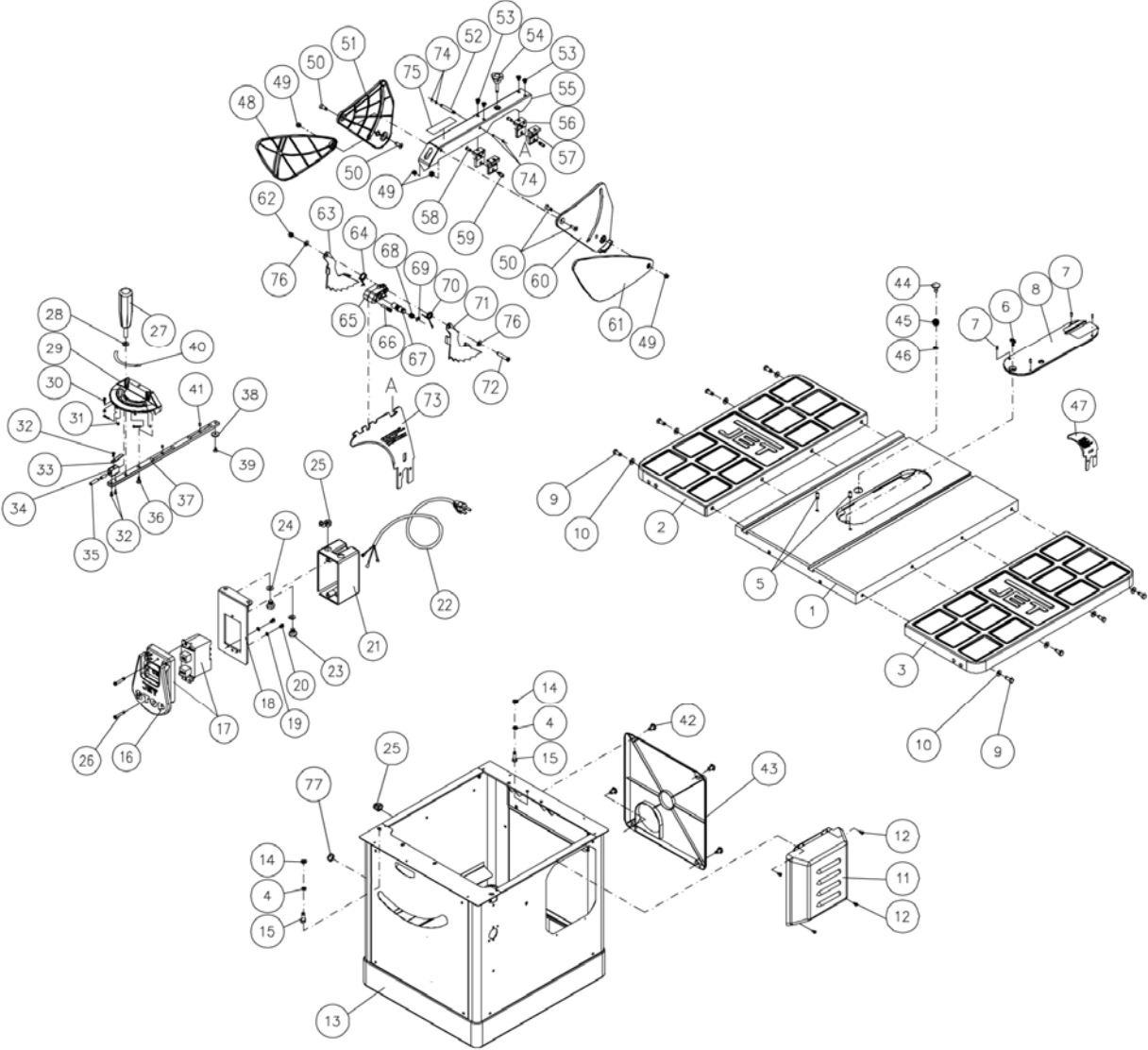

16.2.2 Table and Cabinet – Parts List

Index No	Part No	Description	Size	Qty
1	JPS10TSR-301	Table		1
2	JPS10TS-302	Left Steel Extension Wing		1
3	JPS10TS-303	Right Steel Extension Wing		1
4	TS-2361081	Lock Washer	M8	3
5	TS-1524051	Socket Set Screw	M8x20	2
	JPS10TSR-TIA	Table Insert Assembly (#6 thru #8)		1
6	JPS10TSR-306	Lock Knob		1
7	TS-1522041	Socket Set Screw	M5-0.8Px12	4
8	JPS10TSR-308	Table Insert		1
9	TS-1490031	Hex Cap Screw	M8x20	8
10	TS-1550061	Flat Washer	M8	8
11	JPS10TS-311	Cover		1
12	TS-1532032	Phillips Pan Head Machine Screw	M4x10	4
13	JPS10TSR-313	Cabinet		1
14	TS-1550061	Flat Washer	M8	3
15	TS-1490031	Hex Cap Screw	M8x20	3
16	JPS10TS-342	STOP Switch Paddle		1
17	JPS10TS-343	Main Switch w/ Face Plate		1
18	JPS10TS-344	Switch Plate		1
19	JPS10TS-345	External Tooth Lock Washer	M4	2
20	TS-2171012	Phillips Pan Head Machine Screw	M4x6	2
21	JPS10TS-347	Switch Box		1
22	JPS10TS-348	Power Cord		1
23	TS-1490011	Hex Cap Screw	M8x10	2
24	TS-1550061	Flat Washer	M8	2
25	JPS10TS-351	Strain Relief	SBRS-3	3
26	TS-2284302	Phillips Pan Head Machine Screw	M4x30	2
	JPS10TS-MG	Miter Gauge Assembly (#27 thru #41)		1
27	JPS10TS-327	Handle		1
28	TS-0680041	Flat Washer	3/8"	1
29	JWTS10-329	Miter Gauge Body		1
30	TS-2284202	Phillips Pan Head Machine Screw	M4x20	3
31	TS-1540021	Hex Nut	M4	3
32	TS-1533032	Phillips Pan Head Machine Screw	M5x10	3
33	JWTS10-333	Pointer		1
34	JWTS10-334	Bracket		1
35	JWTS10-335	Stop Pin		1
36	JWTS10-336	Screw		1
37	JPS10TS-337	Miter Bar		1
38	JWTS10-338	Guide Washer		1
39	JWTS10-339	Flat Head Screw	M6x8	1
40	JPS10TS-340	Scale		1
41	TS-0270011	Socket Set Screw	5/16"-18x1/4"	2
42	JPS10TS-357	Lock Knob		4
43	JPS10TS-358	Dust Chute Cover		1
44	JPS10TSR-344	Lock Plunger		1
45	JPS10TS-360	Spring		1
45	JPS10TS-361	E-Clip	ETW-7	1
47	JPS10TSR-347	Low Profile Riving Knife		1
	JPS10TSR-BGA	Blade Guard Assembly (#48 thru #76)		1
	JPS10TSR-UGA	Upper Guard Assembly (#48 thru #61,74,75)		1
48	JPS10TSR-348	Left Side outer Blade Guard		1
49	TS-1541011	Nylon Lock Hex Nut	M5	4
50	JPS10TSR-350	Flat Head Screw	M5-0.8Px15	4
51	JPS10TSR-351	Left Side Inner Blade Guard		1
52	JPS10TSR-352	Shaft		1
53	JPS10TSR-353	Pan Head Screw	M5-0.8Px6	4

Index No	Part No	Description	Size	Qty
54	JPS10TSR-354	Lock Knob		1
55	JPS10TSR-355	Support Arm		1
56	JPS10TSR-356	Left Fixing Bracket		2
57	JPS10TSR-357	Right Fixing Bracket		2
58	TS-1532032	Phillips Pan Head Machine Screw	M4-0.7Px10	2
59	JPS10TSR-359	Lock Pin		2
60	JPS10TSR-360	Right Side Inner Blade Guard		1
61	JPS10TSR-361	Right Side Outer Blade Guard		1
	JPS10TSR-AKPA	Anti-Kickback Pawl Assembly (#62 thru #72,76)		1
62	TS-1541011	Nylon Lock Hex Nut	M5-0.8P	1
63	JPS10TSR-363	Left Side Anti-kickback Pawl		1
64	JPS10TSR-364	Left Side Spring		1
65	JPS10TSR-365	Anti-Kickback Pawl Bracket		1
66	JPS10TSR-366	Lock Pin		1
67	JPS10TSR-367	Lock Shaft		1
68	JPS10TSR-368	Spring		1
69	JPS10TS-361	E-Clip	ETW-7	1
70	JPS10TSR-370	Right Side Spring		1
71	JPS10TSR-371	Right Side Anti-kickback Pawl		1
72	TS-2285302	Phillips Pan Head Machine Screw	M5-0.8Px30	1
73	JPS10TSR-373	Riving Knife		1
74	JPS10TSR-374	O-Ring	P3	4
75	JPS10TSR-375	Warning Label		1
76	TS-1550031	Flat Washer	M5	2
77	JPS10TSR-377	Cap		1

16.3.1 Stand Assembly – Exploded View

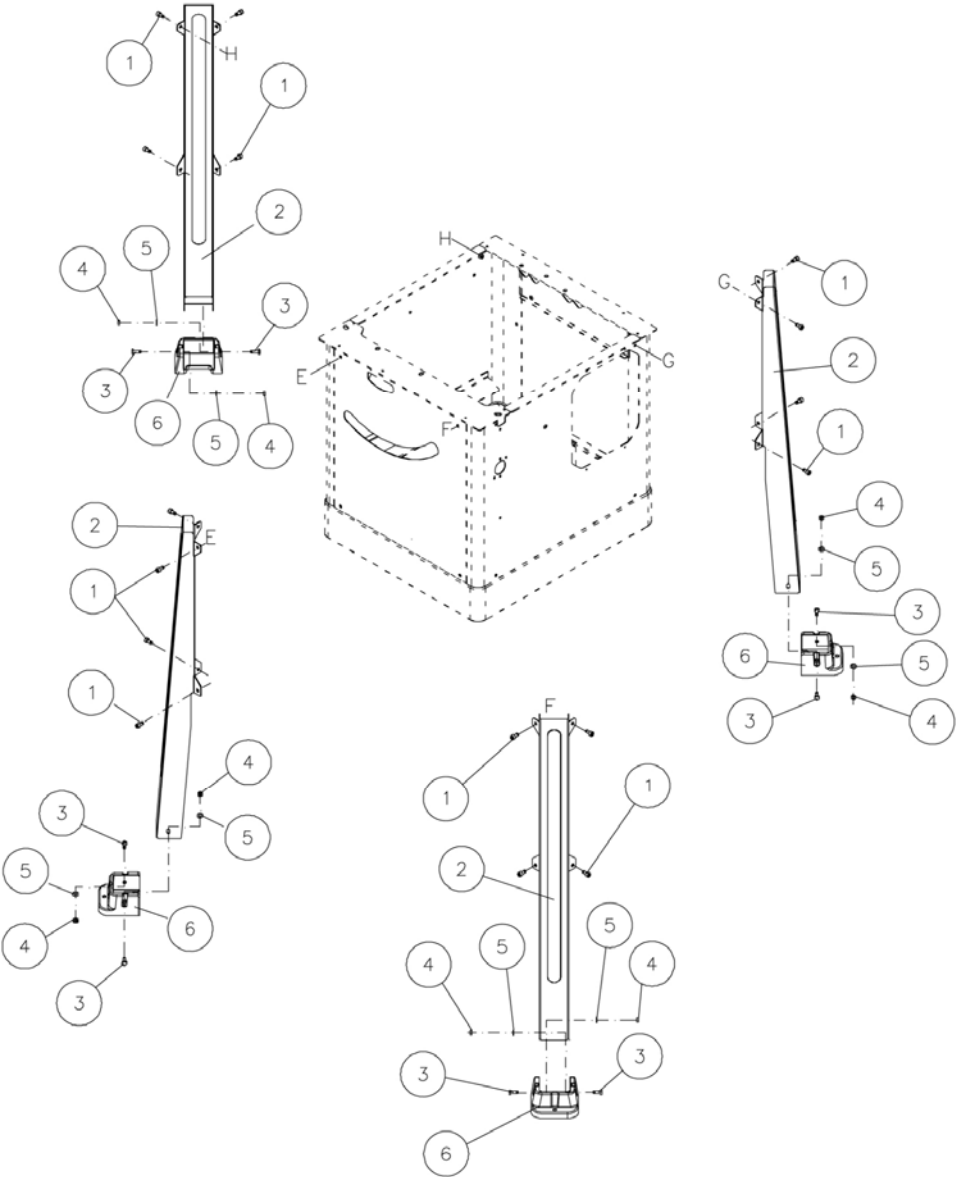

16.3.2 Stand Assembly – Parts List

Index No	Part No	Description	Size	Qty
1.....	TS-2246122	Socket Head Button Screw.....	M6x12.....	16
2.....	JPS10TSR-402.....	Leg.....		4
3.....	TS-1482031	Hex Cap Screw	M6x16.....	8
4.....	TS-2311061	Hex Nut.....	M6.....	8
5.....	TS-1550041	Flat Washer.....	M6.....	8
6.....	JPS10TS-406.....	Foot.....		4
.....	JPS10TS-SHP.....	Stand Hardware Package (#1,3,4,5).....		

16.4.1 Cast Iron Wings – Exploded View

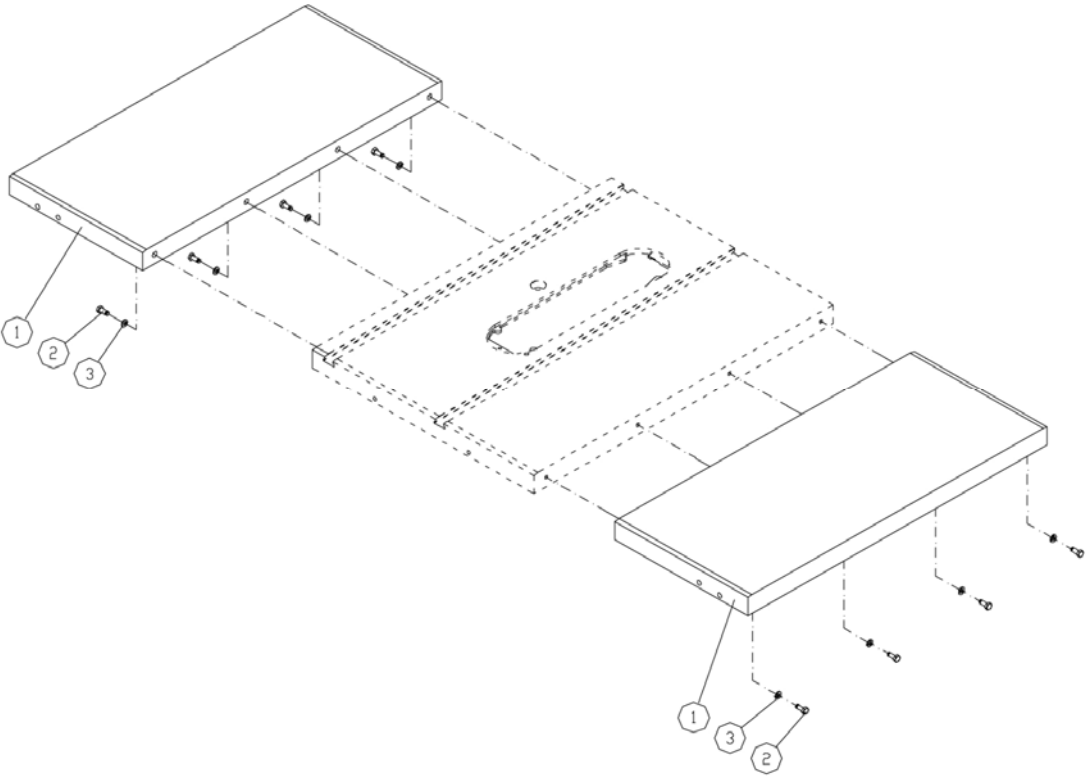

16.4.2 Cast Iron Wings – Parts List

Index No.	Part No.	Description	Size	Qty
1.....	JPS10TS-501	Cast Iron Wing.....		2
2.....	TS-1490031	Hex Cap Screw	M8x20.....	8
3.....	TS-1550061	Flat Washer	M8.....	8

17.1 Electrical Connections – 115V

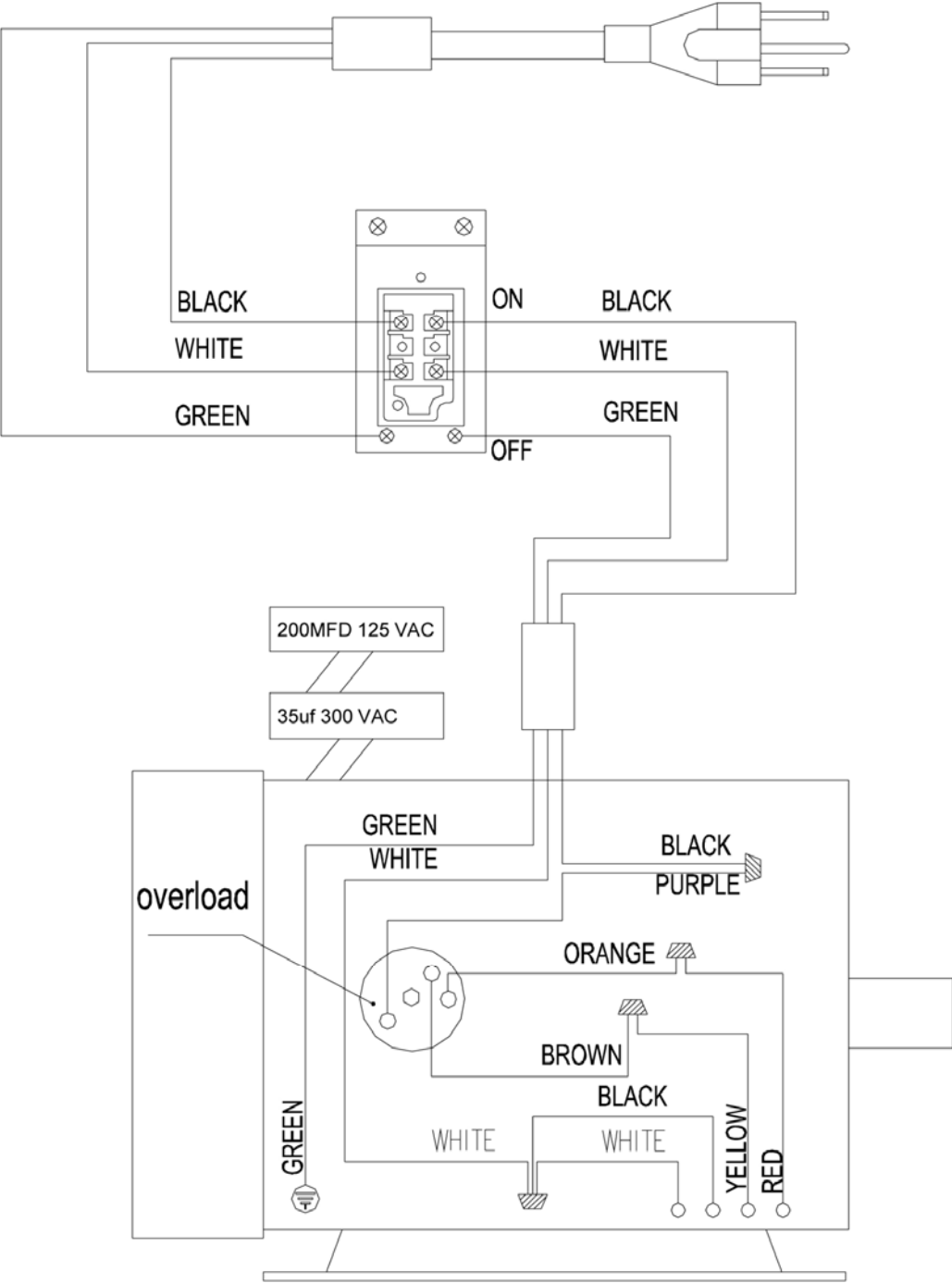

17.2 Electrical Connections – 230V

