



SERVICE PARTS LIST

BULLETIN NO.
54-44-0539

SPECIFY CATALOG NO. AND SERIAL NO. WHEN ORDERING PARTS		REVISED BULLETIN 54-44-0538	DATE Nov. '94
POWER UNIT			
CATALOG NO. 6851	STARTING SERIAL NO. 758B	WIRING INSTRUCTION 58-01-0024	

EXAMPLE:
Component Parts (Small #)
Are Included When Ordering
The Assembly (Large #).

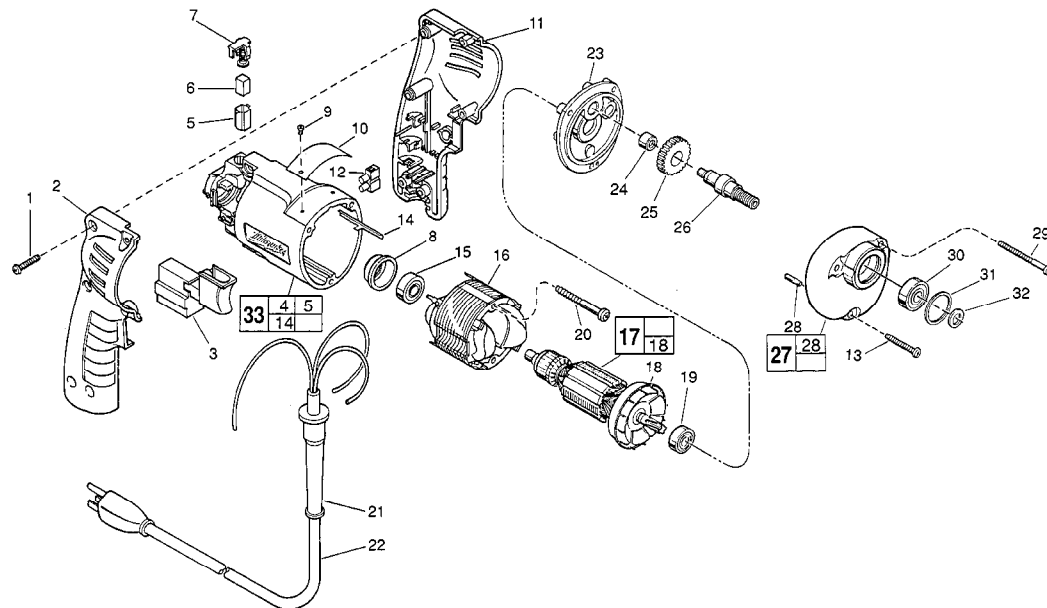

FIG.	PART NO.	DESCRIPTION OF PART	NO. REQ.	FIG.	PART NO.	DESCRIPTION OF PART	NO. REQ.
	1	06-82-7284 8-16 x 3/4" Pan Hd. Slit. Plas. T-20	(6)	29	06-82-7344	7-18 x 1-1/2" Pan Hd. Slit. Plast. T-20	(2)
	2	31-44-1705 Right Handle Half	(1)	30	02-04-1020	Ball Bearing	(1)
	3	23-66-1250 Speed Control Switch	(1)	31	34-80-1400	Retaining Ring	(1)
	4	23-94-6225 Ground Wire Assembly (Not Shown)	(1)	32	45-88-7940	Washer	(1)
	5	22-20-0830 Brush Tube	(2)	★ 33	14-38-0601	Motor Housing Assembly	(1)
	6	22-16-0275 Carbon Brush	(2)				
	7	23-52-1560 Brush Spring Assembly	(2)	FIG. LUBRICATION:			
	8	22-72-0100 Bearing Cup	(1)	27		Use 1-1/8 Oz. of Type "E" Grease, No. 49-08-4122, in Gear Case.	
★	9	06-72-1720 Nameplate Rivet	(2)	FIG. NOTES			
	10	12-99-0850 Service Nameplate	(1)	1		Torque to 18-28 In./Lbs.	
	11	31-44-1700 Left Handle Half	(1)	13,20,29		Torque to 15-20 In./Lbs.	
	12	22-56-0456 Terminal Block	(1)	8		Place in motor housing before inserting armature.	
	13	06-82-7308 7 -18x 1-1/8" Pan Hd. Slit. Plast. T-20	(1)	24		Press flush to casting surface.	
	14	44-60-0530 Ground Pin	(1)	15,19		Seal towards armature.	
	15	02-04-0645 Ball Bearing	(1)	30		Seal towards retaining ring.	
	16	18-11-0060 120 V Field	(1)				
	17	16-10-0440 120 V D.I. Armature	(1)				
	18	22-84-0760 Fan Assembly	(1)				
	19	02-04-0847 Ball Bearing	(1)				
	20	06-82-7393 7-18 x 2" Pan Hd. Slit. Plast. T-20	(2)				
	21	44-76-0210 Cord Protector	(1)				
	22	22-64-3180 Cord Set	(1)				
	23	28-28-1950 Diaphragm	(1)				
	24	02-50-1620 Needle Bearing	(1)				
	25	32-75-3260 Spindle Gear	(1)				
	26	38-50-5671 Reversing Spindle	(1)				
★	27	14-30-0610 Gear Case Assembly	(1)				
	28	06-65-0825 1/8 x 1/2" Groove Pin 5	(1)				

MILWAUKEE ELECTRIC TOOL CORPORATION
13135 W. LISBON RD., BROOKFIELD, WI 53005