



# SERVICE PARTS LIST

**BULLETIN NO.**  
**55-42-7000**

SPECIFY CATALOG NO. AND SERIAL NO. WHEN ORDERING PARTS		REVISED BULLETIN	DATE
D.I. DRYWALL SCREWDRIVER			July '97
CATALOG NO. 6755-55	SERIAL NUMBER 792A	WIRING INSTRUCTION 58-03-1401	



**EXAMPLE:**  
Component Parts (Small #) Are Included  
When Ordering The Assembly (Large #).

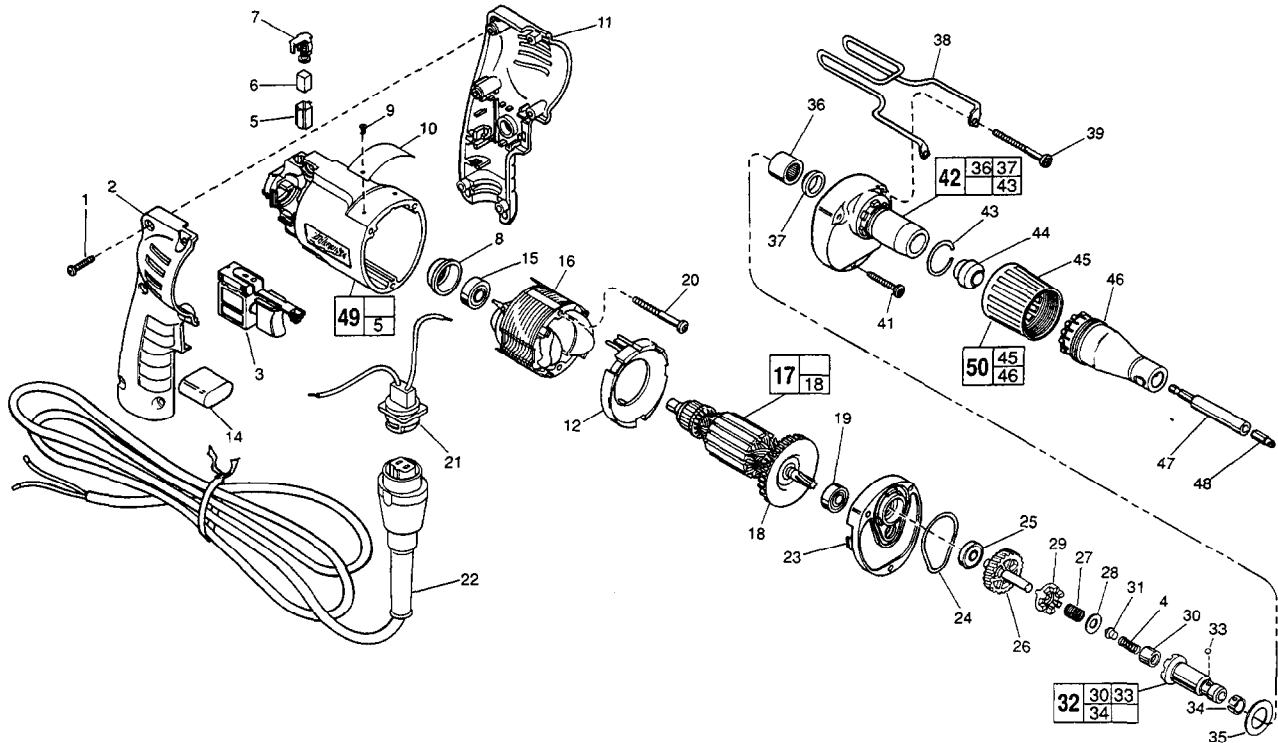

FIG.	PART NO.	DESCRIPTION OF PART	NO. REQ.
1	06-82-7284	8-16 x 3/4" Pan Hd. Plast. T-20	(6)
2	31-44-1845	Right Handle Half	(1)
3	23-66-2146	Switch	(1)
4	40-50-0095	Separator Spring	(1)
5	22-20-0830	Brush Tube	(2)
6	22-16-0275	Carbon Brush	(2)
7	23-52-1570	Brush Spring Assembly	(2)
8	22-72-0100	Bearing Cup	(1)
9	06-72-1720	Nameplate Rivet	(2)
10	12-99-0860	Service Nameplate	(1)
11	31-44-1840	Left Handle Half	(1)
12	42-14-0360	Baffle	(1)
14	22-33-0450	Suppressor	(1)
15	02-04-0645	Ball Bearing	(1)
16	18-11-0150	Field	(1)
17	16-10-0676	Armature Assembly	(1)
18	22-84-0840	Fan Assembly	(1)
19	02-04-0851	Ball Bearing	(1)
20	06-82-7393	7-18 x 2" Pan Hd. Slit. Plast. T-20	(2)
21	22-56-0688	Blade Housing Assembly	(1)
22	48-76-5011	Quik-Lok Cord Set	(1)
23	25-28-1990	Diaphragm	(1)
24	43-44-0940	Gasket	(1)
25	02-04-0645	Ball Bearing	(1)
26	32-10-1051	Clutch Gear Assembly	(1)
27	40-50-8515	Bias Spring	(1)
28	45-88-0555	Thrust Washer	(1)
29	42-70-0310	Bias Clutch	(1)
30	02-50-2400	Needle Bearing	(1)
31	44-60-0505	Thrust Pin	(1)
32	42-66-0710	Clutch Chuck Assembly	(1)
33	02-02-0130	9/64" Steel Ball	(1)
34	40-50-0510	Retaining Spring	(1)
35	45-88-8350	Stop Washer	(1)
36	02-50-4220	Needle Bearing	(1)

FIG.	PART NO.	DESCRIPTION OF PART	NO. REQ.
37	45-06-0570	Oil Seal	(1)
38	42-70-5120	Belt Clip	(1)
39	06-82-7368	7-18 x 1-3/4" Pan Hd. Slit. Plast. T-20	(2)
41	06-82-7320	7-18 x 1-1/4" Pan Hd. Slit. Plast. T-20	(1)
42	14-30-0435	Gear Case Assembly	(1)
43	44-90-0401	Locator Ring	(1)
44	30-37-0045	Guide	(1)
45	31-58-0510	Locator Sleeve	(1)
46	31-51-0090	Locator	(1)
47	48-32-3065	Magnetic Bit Holder	(1)
48	48-32-1050	Insert Bit - #2 Phillips	(1)
49	14-38-0431	Motor Housing Assembly	(1)
50	49-26-1035	Locator Assembly	(1)

**FIG. LUBRICATION**

- 17,26,27 1/64 Oz. Type "E" Grease, No. 49-08-4122, On Bias Spring.
- 1/64 Oz. In The Clutch Pockets Of The Clutch Gear.
- 1/64 Oz. On Each Side Of Armature Pinion At Clutch Gear.
- 42 3/16 Oz. In Pinion Pocket Of Gear Case.

Apply A Light Film Of "E" Grease To Ball And Needle Bearing Pockets Of The Diaphragm And Gear Case Prior To Pressing Bearings. Apply A Light Film Of "E" Grease To The Lead Chamfer Of Clutch Chuck, Thrust Pin And Separator Spring Prior To Assembly.

**FIG. NOTES**

- 1 Torque To 18-28 In./Lbs.
- 20,41,39 Torque To 15-20 In./Lbs.

**MILWAUKEE ELECTRIC TOOL CORPORATION**  
13135 W. LISBON RD., BROOKFIELD, WI 53005