



SERVICE PARTS LIST

BULLETIN NO.
54-42-5556

SPECIFY CATALOG NO. AND SERIAL NO. WHEN ORDERING PARTS		REVISED BULLETIN 54-42-5555	DATE July '97
D.I. DRYWALL SCREWDRIVER			
CATALOG NO.	6755-1	SERIAL NUMBER	792E
			WIRING INSTRUCTION 58-01-1592



EXAMPLE:
Component Parts (Small #) Are Included
When Ordering The Assembly (Large #).

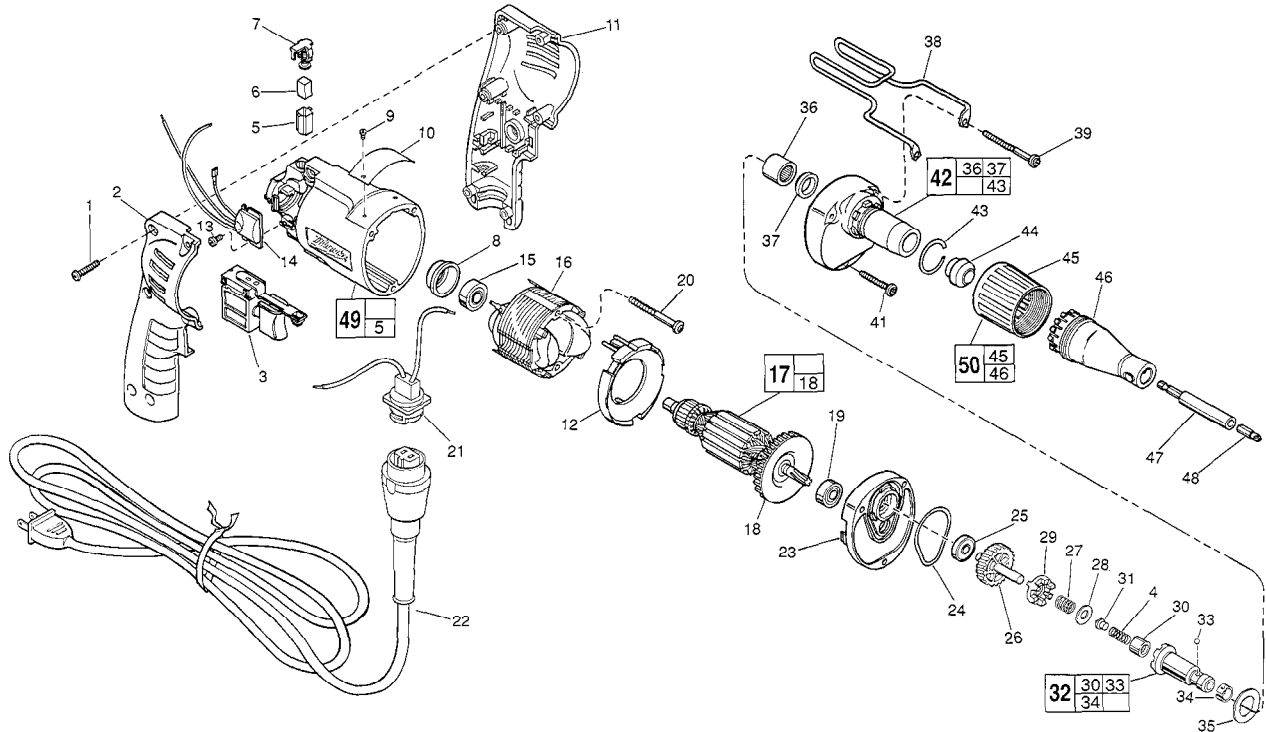

FIG.	PART NO.	DESCRIPTION OF PART	NO. REQ.
	1	8-16 x 3/4" Pan Hd. Plast. T-20	(6)
★	2	Right Handle Half	(1)
	3	Switch	(1)
	4	Separator Spring	(1)
	5	Brush Tube	(2)
	6	Carbon Brush	(2)
	7	Brush Spring Assembly	(2)
	8	Bearing Cup	(1)
	9	Nameplate Rivet	(2)
	10	Service Nameplate	(1)
★	11	Left Handle Half	(1)
	12	Baffle	(1)
	13	4-20 x 1/4" Pan Hd. Plast. T-10	(1)
	14	Remote Module Assembly	(1)
	15	Ball Bearing	(1)
	16	Field	(1)
	17	Armature Assembly	(1)
	18	Fan Assembly	(1)
	19	Ball Bearing	(1)
	20	7-18 x 2" Pan Hd. Slit. Plast. T-20	(2)
★	21	Blade Housing	(1)
★	22	Quik-Lok Cord Set	(1)
	23	Diaphragm	(1)
	24	Gasket	(1)
	25	Ball Bearing	(1)
★	26	Clutch Gear Assembly	(1)
	27	Bias Spring	(1)
	28	Thrust Washer	(1)
	29	Drive Clutch	(1)
	30	Needle Bearing	(1)
	31	Thrust Pin	(1)
	32	Clutch Chuck Assembly	(1)
	33	9/64" Steel Ball	(1)
	34	Retaining Spring	(1)
	35	Stop Washer	(1)
	36	Needle Bearing	(1)

FIG.	PART NO.	DESCRIPTION OF PART	NO. REQ.
	37	Oil Seal	(1)
	38	Belt Clip	(1)
	39	7-18 x 1-3/4" Pan Hd. Slit. Plast. T-20	(2)
	41	7-18 x 1-1/4" Pan Hd. Slit. Plast. T-20	(1)
	42	Gear Case Assembly	(1)
	43	Locator Ring	(1)
	44	Guide	(1)
	45	Locator Sleeve	(1)
	46	Locator	(1)
	47	Magnetic Bit Holder	(1)
	48	Insert Bit - #2 Phillips	(1)
	49	Motor Housing Assembly	(1)
	50	Locator Assembly	(1)

FIG. LUBRICATION

- 17,26,27 1/64 Oz. Type "E" Grease, No. 49-08-4122, On Bias Spring.
1/64 Oz. In The Clutch Pockets Of The Clutch Gear.
1/64 Oz. On Each Side Of Armature Pinion At Clutch Gear.
- 42 3/16 Oz. In Pinion Pocket Of Gear Case.

Apply A Light Film Of "E" Grease To Ball And Needle Bearing Pockets Of The Diaphragm And Gear Case Prior To Pressing Bearings. Apply A Light Film Of "E" Grease To The Lead Chamfer Of Clutch Chuck, Thrust Pin And Separator Spring Prior To Assembly.

FIG. NOTES

- 1 Torque To 18-28 In./Lbs.
- 20,41,39 Torque To 15-20 In./Lbs.
- 13 Torque To 3-5 In./Lbs.

MILWAUKEE ELECTRIC TOOL CORPORATION
13135 W. LISBON RD., BROOKFIELD, WI 53005