



# SERVICE PARTS LIST

**BULLETIN NO.**  
54-42-5555

SPECIFY CATALOG NO. AND SERIAL NO. WHEN ORDERING PARTS		REVISED BULLETIN	DATE
D.I. DRYWALL SCREWDRIVER		54-42-5554	Nov. '94
CATALOG NO.	6755-1	SERIAL NUMBER	792D
		WIRING INSTRUCTION	58-01-1591



**EXAMPLE:**  
Component Parts (Small #) Are Included  
When Ordering The Assembly (Large #).

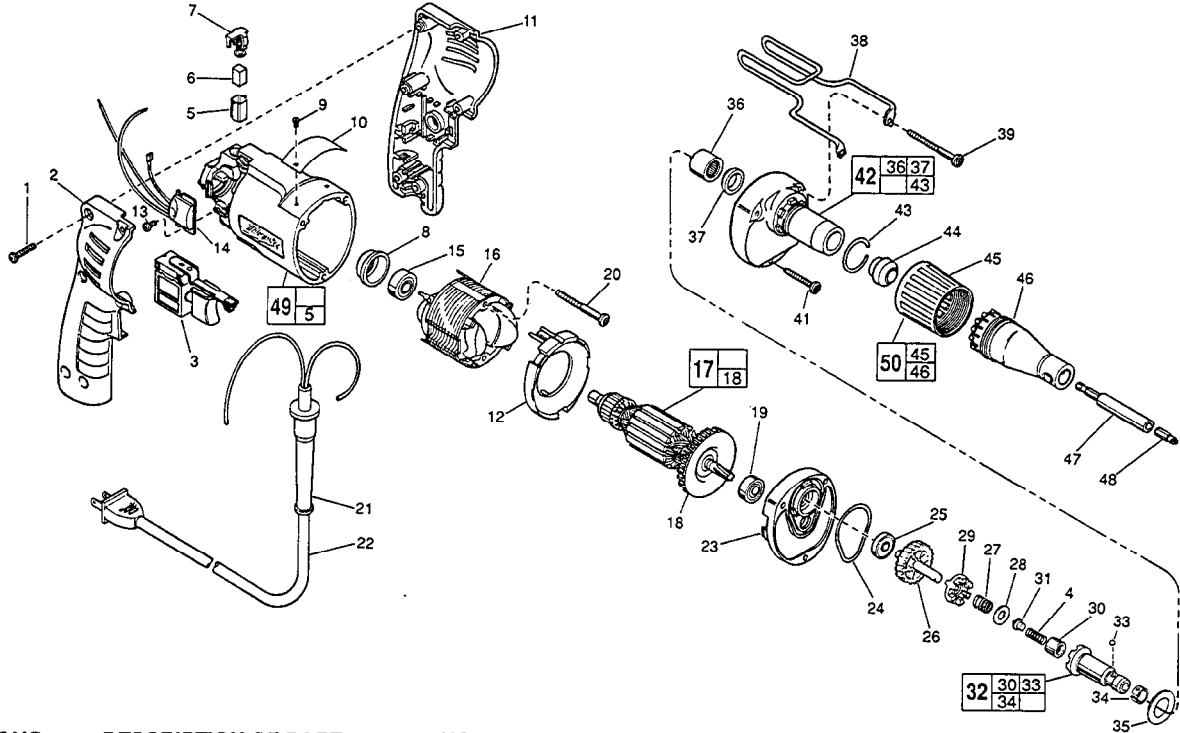

FIG.	PART NO.	DESCRIPTION OF PART	NO. REQ.
	1	06-82-7284 8-16 x 3/4" Pan Hd. Plast. T-20	(6)
	2	31-44-1745 Right Handle Half	(1)
	3	23-66-2145 Switch	(1)
	4	40-50-0095 Separator Spring	(1)
	5	22-20-0830 Brush Tube	(2)
	6	22-16-0275 Carbon Brush	(2)
	7	23-52-1570 Brush Spring Assembly	(2)
	8	22-72-0100 Bearing Cup	(1)
★	9	06-72-1720 Nameplate Rivet	(2)
	10	12-99-0860 Service Nameplate	(1)
	11	31-44-1740 Left Handle Half	(1)
	12	42-14-0360 Baffle	(1)
	13	06-82-7212 4-20 x 1/4" Pan Hd. Plast. T-10	(1)
	14	14-20-0750 Remote Module Assembly	(1)
	15	02-04-0645 Ball Bearing	(1)
	16	18-11-0150 Field	(1)
	17	16-10-0671 Armature Assembly	(1)
	18	22-84-0840 Fan Assembly	(1)
	19	02-04-0851 Ball Bearing	(1)
	20	06-82-7393 7-18 x 2" Pan Hd. Slit. Plast. T-20	(2)
	21	44-76-0210 Cord Protector	(1)
	22	22-64-0891 Cord Set	(1)
	23	25-28-1990 Diaphragm	(1)
	24	43-44-0940 Gasket	(1)
	25	02-04-0645 Ball Bearing	(1)
	26	32-10-1050 Clutch Gear Assembly	(1)
	27	40-50-8515 Bias Spring	(1)
	28	45-88-0555 Thrust Washer	(1)
	29	42-70-0310 Drive Clutch	(1)
	30	02-50-2400 Needle Bearing	(1)
	31	44-60-0505 Thrust Pin	(1)
	32	42-66-0710 Clutch Chuck Assembly	(1)
	33	02-02-0130 9/64" Steel Ball	(1)
	34	40-50-0510 Retaining Spring	(1)
	35	45-88-8350 Stop Washer	(1)
	36	02-50-4220 Needle Bearing	(1)

FIG.	PART NO.	DESCRIPTION OF PART	NO. REQ.
	37	45-06-0570 Oil Seal	(1)
	38	42-70-5120 Belt Clip	(1)
	39	06-82-7368 7-18 x 1-3/4" Pan Hd. Slit. Plast. T-20	(2)
	41	06-82-7320 7-18 x 1-1/4" Pan Hd. Slit. Plast. T-20	(1)
	42	14-30-0435 Gear Case Assembly	(1)
	43	44-90-0401 Locator Ring	(1)
	44	30-37-0045 Guide	(1)
	45	31-58-0510 Locator Sleeve	(1)
	46	31-51-0090 Locator	(1)
	47	48-32-3065 Magnetic Bit Holder	(1)
	48	48-32-1050 Insert Bit - #2 Phillips	(1)
★	49	14-38-0431 Motor Housing Assembly	(1)
	50	49-26-1035 Locator Assembly	(1)

**FIG. LUBRICATION**  
17,26,27 1/64 Oz. Type "E" Grease, No. 49-08-4122, On Bias Spring.  
1/64 Oz. In The Clutch Pockets Of The Clutch Gear.  
1/64 Oz. On Each Side Of Armature Pinion At Clutch Gear.  
42 3/16 Oz. In Pinion Pocket Of Gear Case.

Apply A Light Film Of "E" Grease To Ball And Needle Bearing Pockets Of The Diaphragm And Gear Case Prior To Pressing Bearings. Apply A Light Film Of "E" Grease To The Lead Chamfer Of Clutch Chuck, Thrust Pin And Separator Spring Prior To Assembly.

**FIG. NOTES**  
1 Torque To 18-28 In./Lbs.  
20,41,39 Torque To 15-20 In./Lbs.  
13 Torque To 3-5 In./Lbs.

**MILWAUKEE ELECTRIC TOOL CORPORATION**  
13135 W. LISBON RD., BROOKFIELD, WI 53005