



SERVICE PARTS LIST

BULLETIN NO.
55-42-5160

SPECIFY CATALOG NO. AND SERIAL NO. WHEN ORDERING PARTS		REVISED BULLETIN 55-42-5159	DATE Jan. 2000
SNAP ACTION DRYWALL SCREWDRIVER			
CATALOG NO. 6747-50	STARTING SERIAL NO. 453D	WIRING INSTRUCTION 58-03-0028	

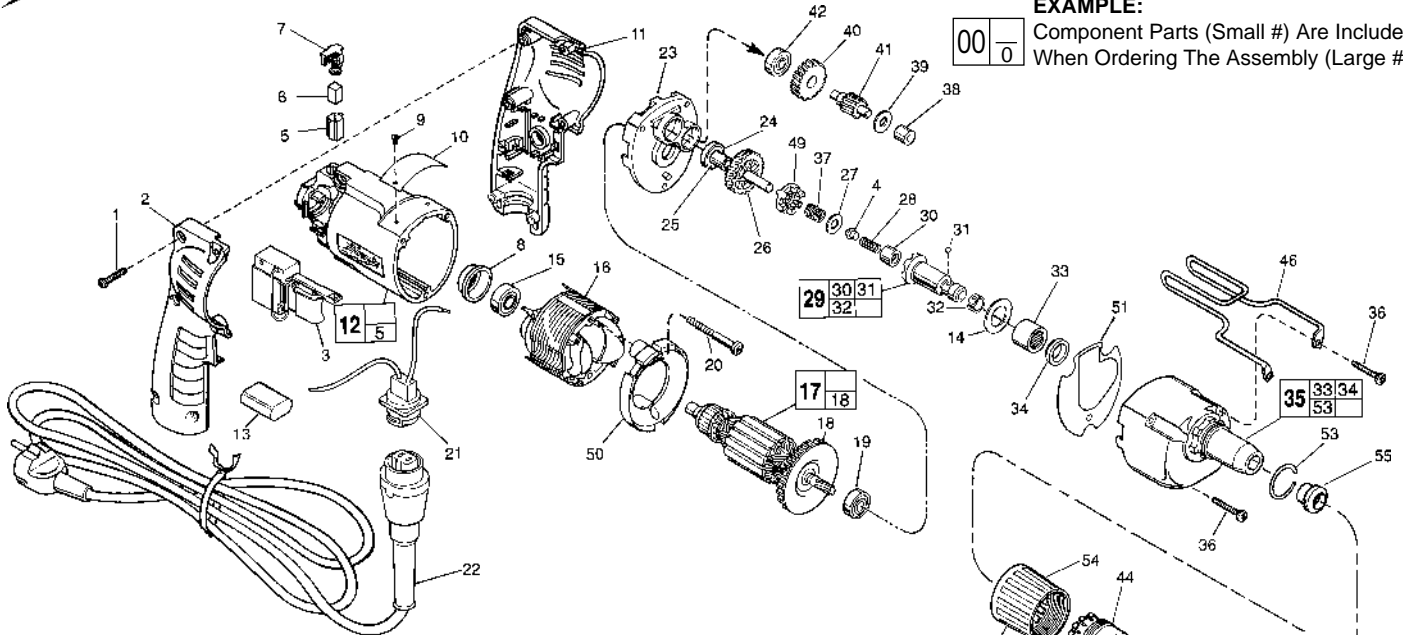

FIG.	PART NO.	DESCRIPTION OF PART	NO. REQ.
1	06-82-7284	8-16 x 3/4" Pan Hd. Slit. Plast. T-20	(6)
2	31-44-1845	Right Handle Half	(1)
3	23-66-2075	TSC Switch	(1)
3	4931 3648 01	Atlas Copco TSC Switch (Australia)	(1)
4	44-60-0505	Thrust Pin	(1)
5	22-20-0830	Brush Tube	(2)
6	22-16-0375	Carbon Brush	(2)
7	23-52-1570	Brush Spring Assembly	(2)
8	22-72-0100	Bearing Cup	(1)
9	06-72-1720	Nameplate Rivet	(2)
10	12-99-0860	Service Nameplate	(1)
11	31-44-1840	Left Handle Half	(1)
12	14-38-0591	Motor Housing Assembly	(1)
13	14-20-0530	Capacitor Assembly	(1)
14	45-88-8350	Stop Washer	(1)
15	02-04-0645	Ball Bearing	(1)
16	18-12-0150	230 Volt Field	(1)
17	16-14-0700	230 Volt Armature	(1)
18	22-84-0880	Fan Assembly	(1)
19	02-04-0851	Ball Bearing	(1)
20	06-82-7203	7-18 x 2-1/8" Pan Hd. Slit. Plast. T-20	(2)
21	22-56-0696	Blade Housing Assembly	(1)
22	48-76-5012	Quik-Lok Cord Set	(1)
22	22-64-0684	Quik-Lok Cord Set (Australia)	(1)
23	28-28-2310	Diaphragm	(1)
24	02-04-0645	Ball Bearing	(1)
25	45-36-1280	Spacer	(1)
26	32-10-4060	Clutch Gear Assembly	(1)
27	45-88-0555	Thrust Washer	(1)
28	40-50-0095	Separator Spring	(1)
29	42-66-0710	Clutch Chuck Assembly	(1)
30	02-50-2400	Needle Bearing	(1)
31	02-02-0130	Steel Ball	(1)
32	40-50-0510	Bit Retaining Spring	(1)
33	02-50-4220	Needle Roller Bearing	(1)
34	45-06-0570	Oil Seal	(1)
35	14-30-0745	Gear Case Assembly	(1)
36	06-82-7344	7-18 x 1-1/2" Pan Hd. Slit. Plast. T-20	(3)
37	40-50-8515	Bias Spring	(1)
38	02-50-2400	Needle Bearing	(1)
39	45-88-7990	Thrust Washer	(1)
40	32-40-1614	Intermediate Gear	(1)
41	36-66-9680	Intermediate Pinion Shaft	(1)

FIG.	PART NO.	DESCRIPTION OF PART	NO. REQ.
42	02-04-0645	Ball Bearing	(1)
43	48-32-1050	#2 Insert Bit	(1)
44	31-51-0090	Locator	(1)
45	48-32-3065	Magnetic Bit Holder	(1)
46	42-70-5080	Belt Clip	(1)
49	42-70-0310	Drive Clutch	(1)
50	42-14-0380	Baffle	(1)
51	43-44-4010	Gasket	(1)
52	49-26-1035	Drywall Locator Assembly	(1)
53	44-90-0401	Locator Ring	(1)
54	31-58-0510	Locator Sleeve	(1)
55	30-37-0046	Nose Guide	(1)

FIG. LUBRICATION
17,26,37 1/64 Oz. Type "E" Grease, No. 49-08-4122, On Bias Spring.
1/64 Oz. In The Clutch Pockets Of The Clutch Gear.
35 1/64 Oz. On Each Side Of Armature Pinion At Clutch Gear.
7/8 Oz. In Pinion Pocket Of Gear Case, Near Intermediate Shaft Needle Bearing In Gear Case.

Apply A Light Film Of "E" Grease To Ball And Needle Bearing Pockets Of The Diaphragm And Gear Case Prior To Pressing Bearings. Apply A Light Film Of "E" Grease To The Lead Chamfer Of Clutch Chuck, Thrust Pin And Separator Spring Prior To Assembly.

FIG.	NOTES
1	Torque to 18-28 In./Lbs.
20,36	Torque to 15-20 In./Lbs.
47	Torque to 3-5 In./Lbs.
8	Place in motor housing before inserting armature.
30,33,38	Press only on end with manufacturer ID.
33,38	Press flush to casting surface.
34	Spring side towards rear of gear case.
15	Seal towards armature.
24,42	Seal Away From Armature

MILWAUKEE ELECTRIC TOOL CORPORATION
13135 W. LISBON RD., BROOKFIELD, WI 53005
Drwg. 2