



SERVICE PARTS LIST

BULLETIN NO.
55-42-5157

SPECIFY CATALOG NO. AND SERIAL NO. WHEN ORDERING PARTS		REVISED BULLETIN	DATE
0-2500 RPM REV. DRYWALL SCREWDRIVER		55-42-5156	Apr. '94
CATALOG NO. 6747-4	STARTING SERIAL NO. 453A	WIRING INSTRUCTION 58-03-0023	

EXAMPLE:
Component Parts (Small #)
Are Included When Ordering
The Assembly (Large #).

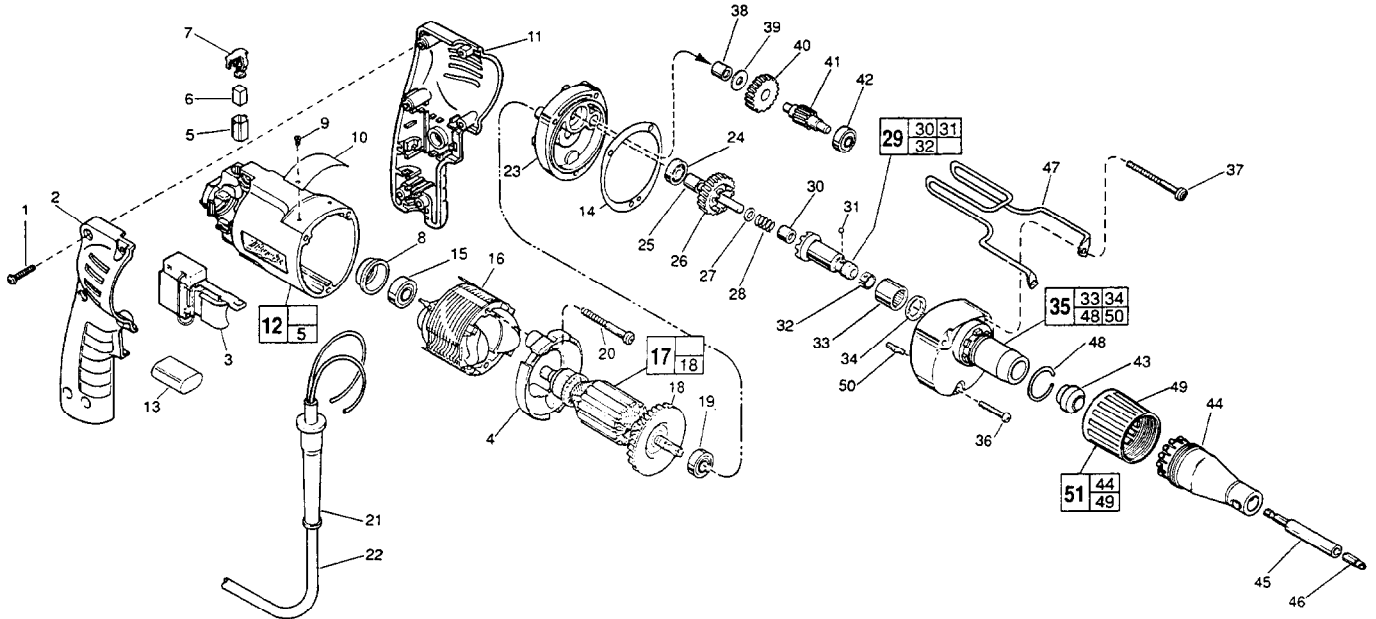

FIG. PART NO.	DESCRIPTION OF PART	NO. REQ.	FIG. PART NO.	DESCRIPTION OF PART	NO. REQ.
1	8-16 x 3/4" Pan Hd. Slit. Plast. T-20	(6)	★ 35	14-30-0740 Gear Case Assembly	(1)
2	31-44-1745 Right Handle Half	(1)	36	06-82-7344 7-18 x 1-1/2" Pan Hd. Slit. Plast. T-20	(1)
3	23-66-2075 Speed Control Switch	(1)	37	06-82-7464 7-18 x 2-3/4" Pan Hd. Slit. Plast. T-20	(2)
★ 4	42-14-0380 Baffle	(1)	38	02-50-2410 Needle Bearing	(1)
5	22-20-0830 Brush Tube	(2)	39	45-88-7990 Thrust Washer	(1)
6	22-16-0375 Carbon Brush	(2)	40	32-40-1612 Intermediate Gear	(1)
7	23-52-1570 Brush Spring Assembly	(2)	41	36-66-4101 Intermediate Pinion Shaft	(1)
8	22-72-0100 Bearing Cup	(1)	★ 42	02-04-0645 Ball Bearing	(1)
9	06-85-0200 Nameplate Screw	(2)	★ 43	430-37-0045 Guide	(1)
10	12-99-0570 Service Nameplate	(1)	★ 44	31-51-0090 Locator	(1)
11	31-44-1740 Left Handle Half	(1)	45	48-32-3065 Magnetic Bit Holder	(1)
12	14-38-0590 Motor Housing Assembly	(1)	46	48-32-1050 #2 Insert Bit	(1)
★ 13	14-20-0530 Capacitor Assembly	(1)	47	42-70-5080 Belt Clip	(1)
★ 14	43-44-0925 Gasket	(1)	★ 48	44-90-0401 Locator Ring	(1)
15	02-04-0645 Ball Bearing	(1)	★ 49	31-58-0510 Locator Sleeve	(1)
16	18-12-0150 Field	(1)	50	06-65-0825 1/8 x 1/2 Groove Pin 5	(1)
★ 17	16-14-0690 Armature	(1)	★ 51	49-26-1035 Locator Assembly	(1)
★ 18	22-84-0880 Fan Assembly	(1)			
★ 19	02-04-0851 Ball Bearing	(1)			
★ 20	06-82-7203 7-18 x 2-1/8" Pan Hd. Slit. Plast. T-20	(2)			
21	44-76-0210 Cord Protector	(1)			
22	22-64-4480 Cord Set	(1)			
★ 23	28-28-1961 Diaphragm	(1)			
24	02-04-0645 Ball Bearing	(1)			
25	45-36-1280 Spacer	(1)			
26	32-10-4045 Clutch Gear Assembly	(1)			
27	45-88-0712 Thrust Washer	(1)			
28	40-50-6600 Separator Spring	(1)			
★ 29	42-66-0775 Clutch Chuck Assembly	(1)			
30	02-50-2400 Needle Bearing	(1)			
31	02-02-0130 Steel Ball	(1)			
32	40-50-0510 Bit Retaining Spring	(1)			
33	02-50-4220 Needle Roller Bearing	(1)			
★ 34	45-06-0570 Oil Seal	(1)			

FIG.	LUBRICATION
35	1-1/2 Oz. Type "E" Grease, No. 49-08-4122. Place Near Intermediate Shaft Ball Bearing In Gear Case.

FIG.	NOTES
1	Torque to 18-22In./Lbs.
20,36,37	Torque to 15-20 In./Lbs.
8	Place in motor housing before inserting armature.
30,33,38	Press only on end with manufacturer ID.
38	Press flush to casting surface.
30	Press 11/64" from clutch face.
33	Press 13/64" from cast surface.
34	Spring side towards rear of gear case.
15,42,24	Seal towards armature.

MILWAUKEE ELECTRIC TOOL CORPORATION
13135 W. LISBON RD., BROOKFIELD, WI 53005