



SERVICE PARTS LIST

**BULLETIN NO.
54-42-5158**

SPECIFY CATALOG NO. AND SERIAL NO. WHEN ORDERING PARTS		REVISED BULLETIN	DATE
0-2500 RPM REV. DRYWALL SCREWDRIVER		54-42-5157	May '93
CATALOG NO. 6747-1	STARTING SERIAL NO. 453-157000 or 453A	WIRING INSTRUCTION 58-01-0023	

EXAMPLE:
Component Parts (Small #)
Are Included When Ordering
The Assembly (Large #).

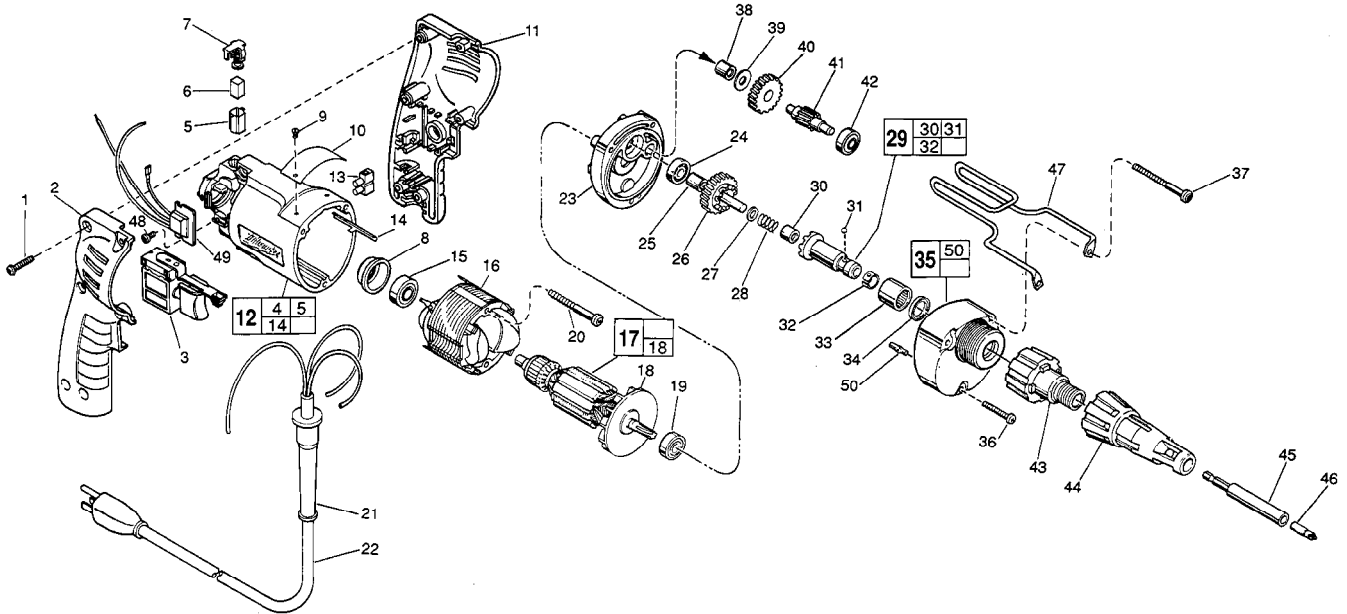

FIG. PART NO.	DESCRIPTION OF PART	NO. REQ.	FIG. PART NO.	DESCRIPTION OF PART	NO. REQ.
1 06-82-7284	8-16 x 3/4" Pan Hd. Slit. Plast. T-20	(6)	35 14-30-0600	Gear Case Assembly	(1)
★ 2 31-44-1745	Right Handle Half	(1)	36 06-82-7344	7-18 x 1-1/2" Pan Hd. Slit. Plast. T-20	(1)
★ 3 23-66-2145	Speed Control Switch	(1)	★ 37 06-82-7464	7-18 x 2-3/4" Pan Hd. Slit. Plast. T-20	(2)
4 23-94-6225	Ground Wire Assembly (Not Shown)	(1)	38 02-50-2410	Needle Bearing	(1)
★ 5 22-20-0830	Brush Tube	(2)	39 45-88-7990	Thrust Washer	(1)
6 22-16-0275	Carbon Brush	(2)	40 32-40-1612	Intermediate Gear	(1)
7 23-52-1560	Brush Spring Assembly	(2)	41 36-66-4101	Intermediate Pinion Shaft	(1)
8 22-72-0100	Bearing Cup	(1)	42 02-04-0640	Ball Bearing	(1)
9 06-85-0200	Nameplate Screw	(2)	43 48-32-2500	Bit Housing	(1)
10 12-99-0850	Service Nameplate	(1)	44 49-26-1040	Locator Assembly	(1)
★ 11 31-44-1740	Left Handle Half	(1)	45 48-32-3065	Magnetic Bit Holder	(1)
★ 12 14-38-0600	Motor Housing Assembly	(1)	46 48-32-1050	#2 Insert Bit	(1)
13 22-56-0456	Terminal Block	(1)	47 42-70-5080	Belt Clip	(1)
14 44-60-0530	Ground Pin	(1)	48 06-82-7212	4-20 x 1/4" Pan Hd. Slit. Plast. T-10	(1)
15 02-04-0645	Ball Bearing	(1)	★ 49 14-20-0650	Remote Electronic Assembly	(1)
16 18-11-0150	120 Volt Field	(1)	50 06-65-0825	1/8 x 1/2 Groove Pin 5	(1)
17 16-10-0380	120 Volt Armature	(1)			
18 22-84-0830	Fan Assembly	(1)	FIG. LUBRICATION		
19 02-04-0848	Ball Bearing	(1)	35	1-1/2 Oz. Type "E" Grease, No. 49-08-4122.	
20 06-82-7393	7-18 x 2" Pan Hd. Slit. Plast. T-20	(2)		Place Near Intermediate Shaft Ball Bearing	
21 44-76-0210	Cord Protector	(1)		In Gear Case.	
★ 22 22-64-1120	Cord Set	(1)	FIG. NOTES		
23 28-28-1960	Diaphragm	(1)	1	Torque to 18-22 In./Lbs.	
24 02-04-0645	Ball Bearing	(1)	20,36, 37	Torque to 15-20 In./Lbs.	
25 45-36-1280	Spacer	(1)	48	Torque to 3-5 In./Lbs.	
26 32-10-4045	Clutch Gear Assembly	(1)	8	Place in motor housing before inserting armature.	
27 45-88-0712	Thrust Washer	(1)	30,33	Press only on end with manufacturer ID.	
28 40-50-6600	Separator Spring	(1)	33,38	Press flush to casting surface.	
29 42-66-0766	Clutch Chuck Assembly	(1)	30	Press 11/64" from clutch face.	
30 02-50-2400	Needle Bearing	(1)	34	Lip towards front of gear case.	
31 02-02-0130	Steel Ball	(1)	15,19,24	Seal towards armature.	
32 40-50-0510	Bit Retaining Spring	(1)			
33 02-50-4220	Needle Roller Bearing	(1)			
34 45-06-0106	Oil Seal	(1)			