



SERVICE PARTS LIST

BULLETIN NO.
55-42-8001

SPECIFY CATALOG NO. AND SERIAL NO. WHEN ORDERING PARTS		REVISED BULLETIN 55-42-8000	DATE Mar. 2003
DRYWALL SCREWDRIVER			
CATALOG NO. 6743-55	STARTING SERIAL NO. A04B	WIRING INSTRUCTION 58-03-1800	

EXAMPLE:

00	0
----	---

 Component Parts (Small #) Are Included
 When Ordering The Assembly (Large #).

★=Part number change
from previous service
parts list.

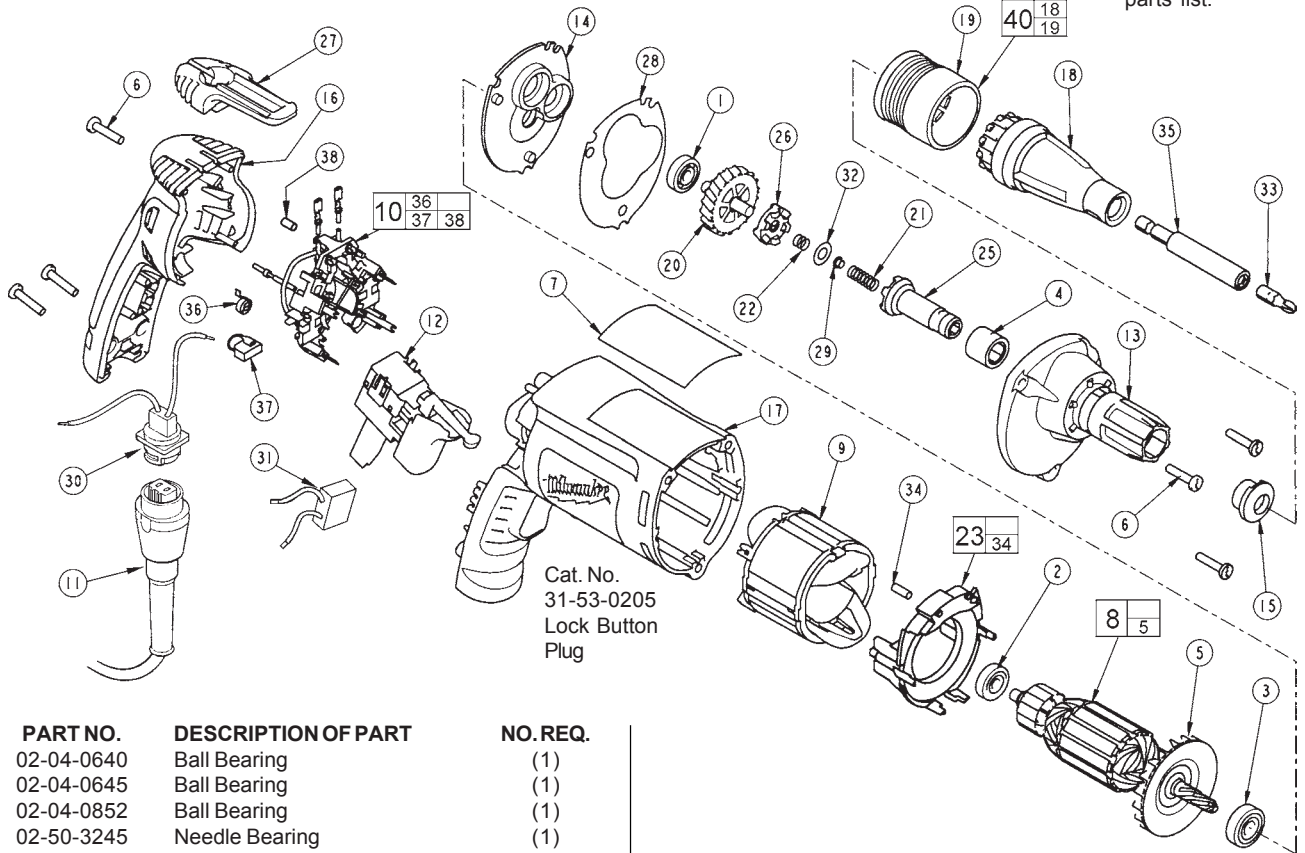

FIG.	PART NO.	DESCRIPTION OF PART	NO. REQ.
1	02-04-0640	Ball Bearing	(1)
2	02-04-0645	Ball Bearing	(1)
3	02-04-0852	Ball Bearing	(1)
4	02-50-3245	Needle Bearing	(1)
5	22-84-0840	Fan	(1)
6	06-82-7275	7-18 x 3/4" Slotted Plastite Torx T-20	(6)
7	12-99-2725	Service Nameplate	(1)
★ 8	16-10-2201	Armature	(1)
9	18-07-2200	Field	(1)
10	22-18-1230	Brush Card Assembly	(1)
11	22-64-0676	Quik-Lok Cord Set	(1)
12	23-66-2585	Switch	(1)
13	28-14-2375	Gearcase	(1)
14	28-28-2315	Diaphragm	(1)
15	30-37-0046	Drywall Nose Guide	(1)
16	31-15-2030	Handle Halve	(1)
17	31-50-2030	Motor Housing	(1)
18	31-51-0095	Drywall Locator	(1)
19	31-58-0515	Snap Sleeve	(1)
★ 20	32-10-0521	Clutch Gear Assembly	(1)
21	40-50-0095	Separator Spring	(1)
22	40-50-8515	Bias Spring	(1)
23	42-14-0460	Baffle Assembly	(1)
25	42-66-0715	Clutch Chuck Assembly	(1)
26	42-70-0310	Drive Clutch	(1)
27	42-70-5280	Belt Clip	(1)
28	43-44-0985	Gasket	(1)
29	44-60-0505	Thrust Pin	(1)
30	22-56-1017	Blade Housing Assembly	(1)
31	22-33-0550	Suppressor	(1)
32	45-88-0555	Clutch Thrust Washer	(1)
33	48-32-1040	#2 Phillips Insert Bit	(1)
34	45-30-0030	Slug	(2)
35	48-32-3065	Magnetic Bit Holder	(1)
36	23-52-1610	Brush Spring	(2)
37	22-18-1310	Brush Assembly	(2)

FIG.	PART NO.	DESCRIPTION OF PART	NO. REQ.
38	45-30-0035	Slug	(1)
40	49-26-1036	Drywall Locator Assembly	(1)

FIG. NOTES:
 4 Needle bearing to have it's seal toward the front of the tool.
 Needle bearing to be pressed .133/.143 under flush.

FIG. LUBRICATION:
 20,22 Place .02 oz. (.5 grams) of type "Y" grease, No 49-08-5270, on bias spring. Place .02 oz. (.5 grams) total of grease in the clutch pockets of clutch gear.

8,13 Place .27 oz. (7.6 grams) of type "Y" grease at the armature pinion location in the gearcase pocket and push down .20".

13,14 Apply a light film of type "Y" grease to needle and ball bearing pockets in diaphragm and gearcase prior to pressing bearings in.

21,32 Place .02 oz. (.5 grams) of type "Y" grease to clutch thrust washer, thrust pin and separator spring during assembly.