

SERVICE PARTS LIST

BULLETIN NO.
54-42-6075

SPECIFY CATALOG NO. AND SERIAL NO. WHEN ORDERING PARTS		REVISED BULLETIN	DATE
1-1/4"-2" SHARPFIRE			Apr. 2002
CATALOG NO.	6706-20	STARTING SERIAL NO.	119A
		WIRING INSTRUCTION	58-01-1805

EXAMPLE:

00
0

 Component Parts (Small #) Are Included
 When Ordering The Assembly (Large #).

NOTE: 6706-20 Includes Magazine Attachment No. 48-05-1000. See Reverse Side.

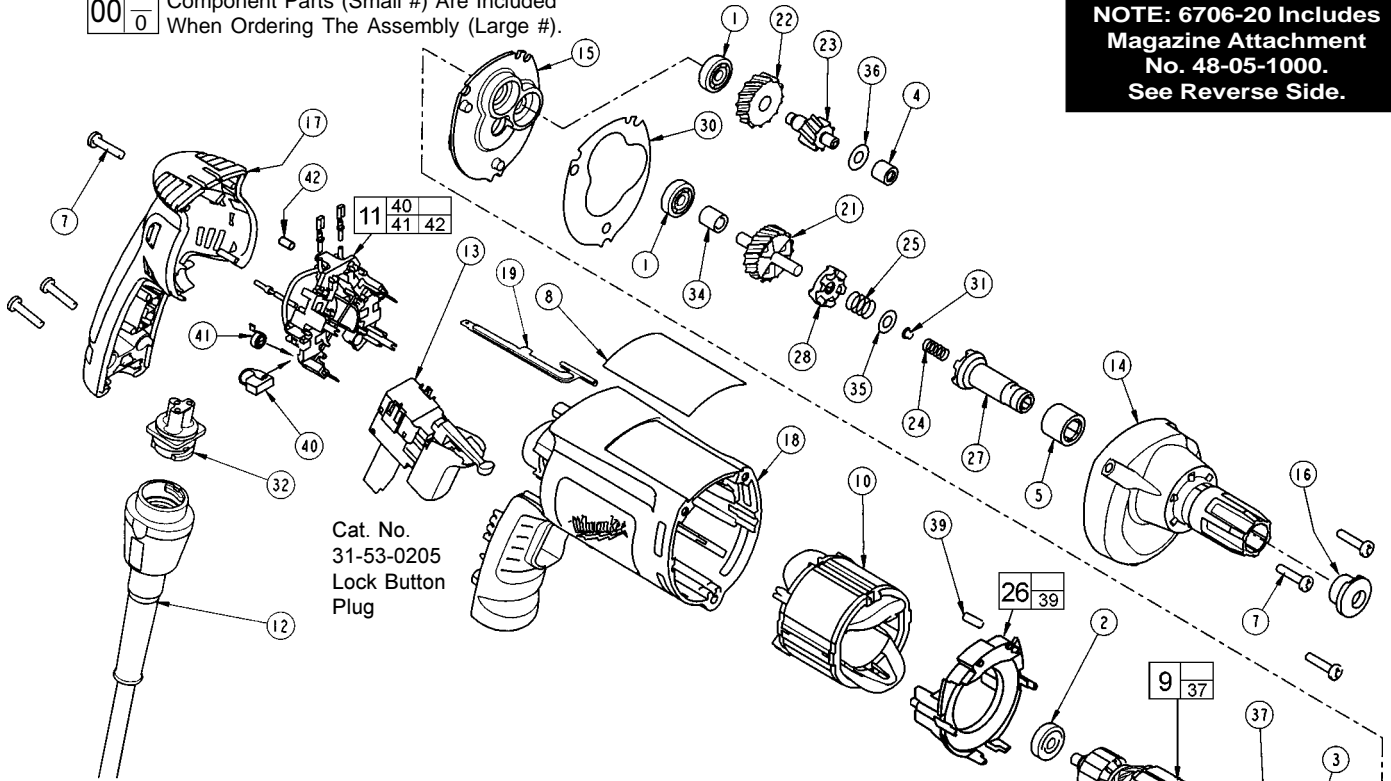

FIG.	PART NO.	DESCRIPTION OF PART	NO. REQ.
1	02-04-0640	Ball Bearing	(2)
2	02-04-0645	Ball Bearing	(1)
3	02-04-0852	Ball Bearing	(1)
4	02-50-2400	Needle Bearing	(1)
5	02-50-3245	Needle Bearing	(1)
7	06-82-7275	7-18 x 3/4 Slotted Plastite Torx T-20	(6)
8	12-99-2565	Service Nameplate	(1)
9	16-10-2205	Armature	(1)
10	18-07-2200	Field	(1)
11	22-18-1210	Brush Card Assembly	(1)
12	48-76-4008	Quik-Lok Cord Set	(1)
13	23-66-2585	Switch	(1)
14	28-14-2380	Gearcase	(1)
15	28-28-2315	Diaphragm	(1)
16	30-37-0046	Drywall Nose Guide	(1)
17	31-15-2030	Handle Halve	(1)
18	31-50-2030	Motor Housing	(1)
19	44-60-1700	Ground Pin	(1)
21	32-10-0525	Clutch Gear Assembly	(1)
22	32-40-0100	Intermediate Gear	(1)
23	36-66-0120	Intermediate Shaft	(1)
24	40-50-0095	Separator Spring	(1)
25	40-50-8515	Bias Spring	(1)
26	42-14-0460	Baffle Assembly	(1)
27	42-66-0715	Clutch Chuck Assembly	(1)
28	42-70-0310	Drive Clutch	(1)
30	43-44-0985	Gasket	(1)
31	44-60-0505	Thrust Pin	(1)
32	22-56-1010	Pin Housing Assembly	(1)
34	45-36-1280	Spacer	(1)
35	45-88-0555	Clutch Thrust Washer	(1)
36	45-88-7990	Thrust Washer	(1)
37	22-84-0845	Fan Assembly	(1)
39	45-30-0030	Slug	(2)
40	22-18-1310	Brush Assembly	(2)

FIG.	PART NO.	DESCRIPTION OF PART	NO. REQ.
41	23-52-1610	Brush Spring	(2)
42	45-30-0035	Slug	(1)

FIG. LUBRICATION:
 21,25 Place .02 oz. (.5 grams) of type "Y" grease, No 49-08-5270, on bias spring. Place .02 oz. (.5 grams) total of grease in the clutch pockets of clutch gear.

14 Place .11 oz. (3.1 grams) of type "Y" grease on top of the inserted intermediate needle bearing. After inserting the pinion assembly, place .48 oz. (13.6 grams) of grease at the armature pinion location in the gearcase pocket and push down .20".

14,15 Apply a light film of type "Y" grease to needle and ball bearing pockets in diaphragm and gearcase prior to pressing bearings in.

24,31 Place .02 oz. (.5 grams) of type "Y" grease to clutch thrust washer, thrust pin and separator spring during assembly.

FIG. NOTES:
 4 Needle bearings to be pressed flush to .010 under flush, from end which has the vendor identification.
 5 Needle bearing to have it's seal toward the front of the tool. Needle bearing to be pressed .133/.143 under flush.



SERVICE PARTS LIST

BULLETIN NO.

SPECIFY CATALOG NO. AND SERIAL NO. WHEN ORDERING PARTS		REVISED BULLETIN	DATE
SCREW-SHOOTER MAGAZINE ATTACHMENT			
CATALOG NO. 48-05-1000	STARTING SERIAL NO. 001016	WIRING INSTRUCTION	

EXAMPLE:

00/0 Component Parts (Small #) Are Included When Ordering The Assembly (Large #).

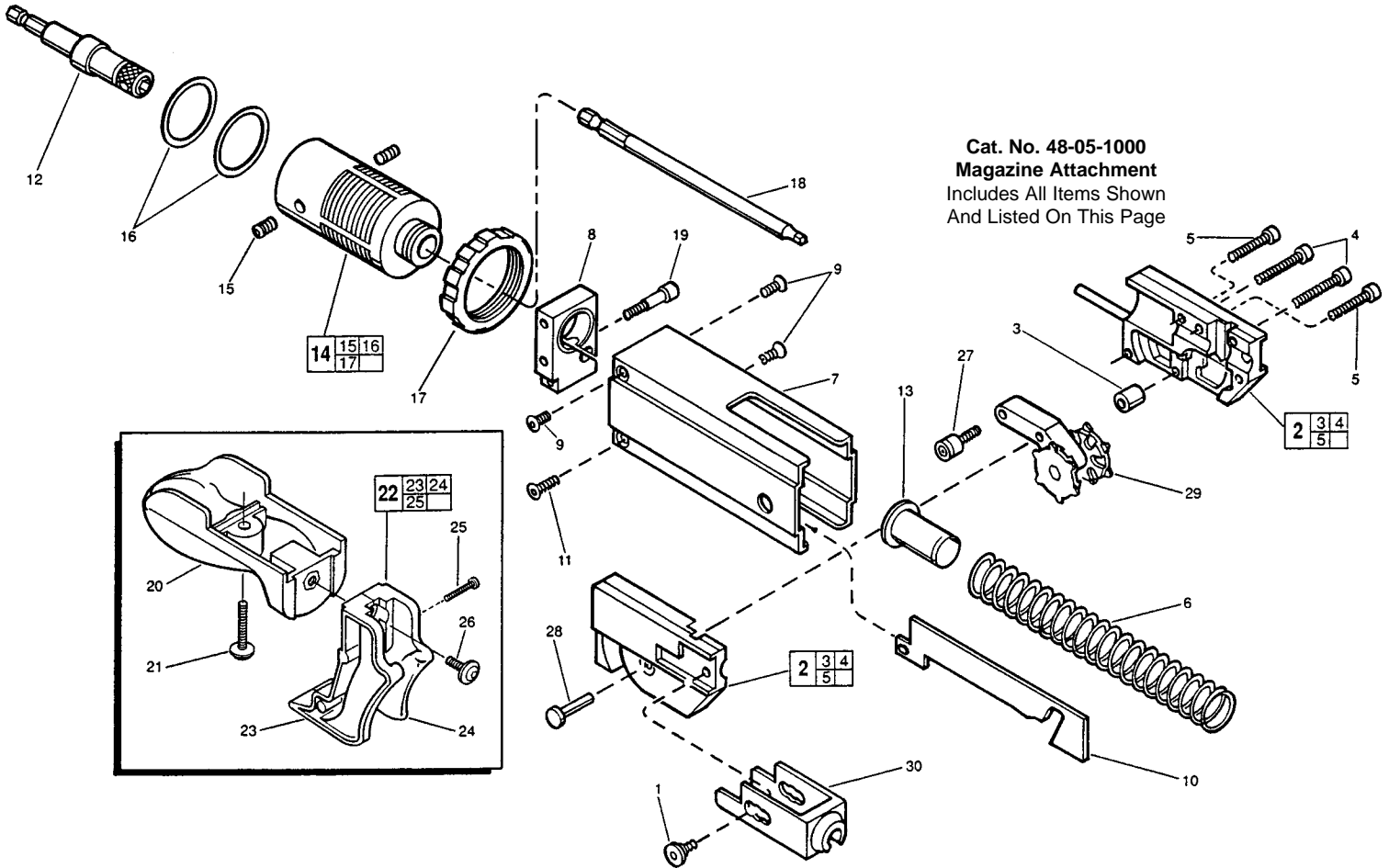

Cat. No. 48-05-1000
Magazine Attachment
 Includes All Items Shown
 And Listed On This Page

FIG.	PART NO.	DESCRIPTION OF PART	NO. REQ.
1	06-81-1700	M5 x 0.8 x 5. lg, 3mm Skt. Hd. Sld. Sc.	2
2	43-56-0310	Gliding Assembly	1
3	42-40-0001	Distance Bearing Bushing	1
4	06-95-1000	M3.5 x 22. lg, Phillips Pan Hd. Plast. Sc.	2
5	06-95-1005	M3.5 x 24. lg, Phillips Pan Hd. Plast. Sc.	2
6	40-50-0405	Spring (Blue)	1
7	43-76-0050	Housing	1
8	44-66-1500	Mounting Plate	1
9	06-81-2000	M4 x 0.7 x 8. lg, 2.5mm Skt. Hd. Flat Sc.	3
10	44-66-0305	Curve Plate	1
11	06-81-2005	M4 x 0.7 x 10. lg, 2.5mm Skt. Hd. Flat Sc.	1
12	43-72-0010	Bit Holder	1
13	43-56-0300	Spring Guide	1
14	43-76-0295	Adapter Assembly	1
15	06-83-1400	M6 x 1.0 x 6. lg, 3mm Socket Set Screw	2
16	34-40-0700	O-Ring	2
17	44-40-0575	Stop Nut	2
18	48-30-1521	120mm #2 Phillips Bit	1
18A	48-30-1526	120mm #2 Square Bit (Not Shown)	1
19	06-81-2010	M5 x 0.8 x 25. lg, 4mm Skt. Hd. Sld. Sc.	1
20	43-62-1230	Handle	1
21	06-81-2015	M5 x 0.8 x 25. lg, 3mm Skt. Hd. Sld. Sc.	1
22	43-56-0305	Plastic Belt Guide	1
23	43-56-0320	Belt Guide-Right	1
24	43-56-0325	Belt Guide-Left	1

FIG.	PART NO.	DESCRIPTION OF PART	NO. REQ.
25	06-95-1010	Assembly Guide Screw	2
26	06-81-2020	M5 x 0.8 x 12 lg, 4mm Skt.1 Hd. Pan Sc.	1
27	06-81-2025	M5 x 0.8, 3mm Socket Hd. Roller Screw	1
28	44-60-1520	Pivot Pin	1
29	42-74-0095	Gear Wheel Unit	1
30	43-46-0200	Depth Control, 1-5/8" to 2"	1
30A	43-46-0205	Depth Control, 1-1/4" to 1-1/2" (Not Shown)	1
	49-96-4800	Allen Key Set-2, 2.5, 3 & 4mm (Not Shown)	1
	10-15-6100	Depth Label (Not Shown)	1
	12-25-1470	Warning Label (Not Shown)	1

FIG. NOTES:
 9,11 Use Loctite 272 on screws.

MILWAUKEE ELECTRIC TOOL CORPORATION
 13135 W. LISBON RD., BROOKFIELD, WI 53005