



SERVICE PARTS LIST

BUL. 54-42-4201

SCREWDRIVER

REVISED BUL. 627-3 DATE Feb. '68

Catalog No. 6640

Starting Serial No. **27-1266**

WIRING INSTR.

Both Model and Serial No. must be furnished to obtain correct parts.

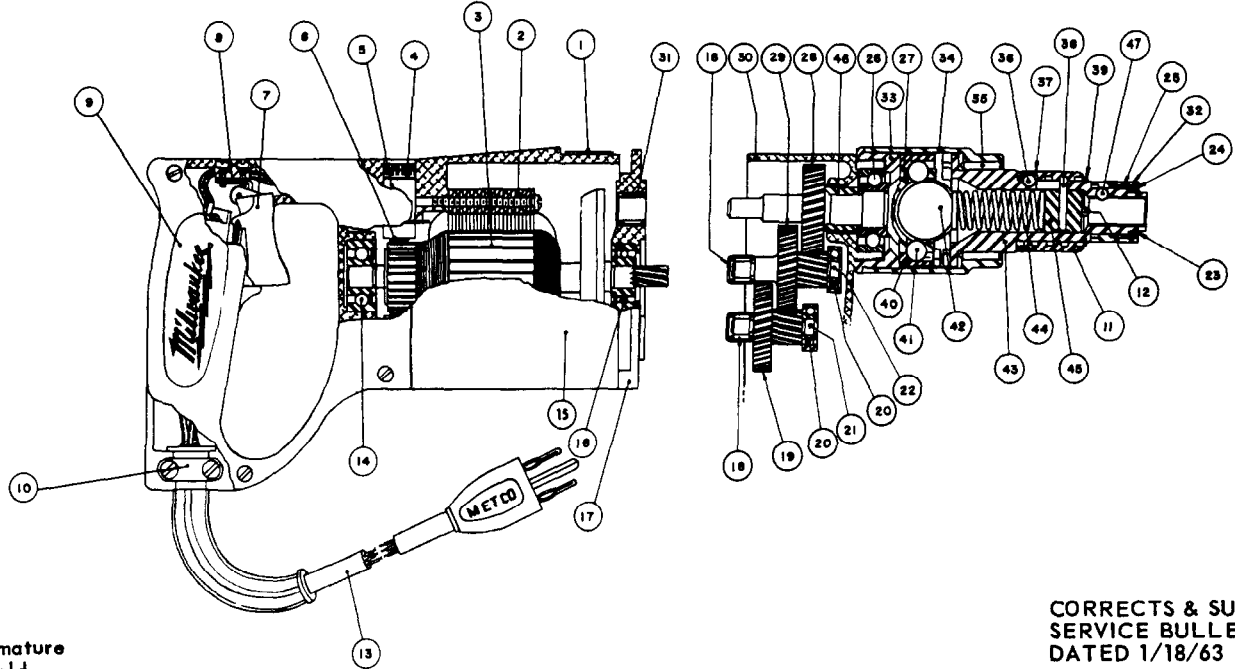

230V
16-46-1190 Armature
18-46-1040 Field

**CORRECTS & SUPERCEDES
SERVICE BULLETIN 627-3
DATED 1/18/63**

FIG.	PART NO.	DESCRIPTION OF PART
1	12-98-0800	Name Plate
★ 2	18-42-1160	Field Assembly
3	16-42-1210	Armature Assembly
4	23-44-0060	Brush Retaining Screw
5	22-22-0080	Brush Holder Assembly
6	22-18-0100	Carbon Brush Assemblies
7	23-66-0230	Switch
8	45-36-0110	Switch Spacer
9	28-20-3141	Handle Cover
10	28-17-0400	Cord Clamp Strap
11	42-76-0120	Adjusting Collar
12	06-65-0855	Type 3 Groove Pin
13	22-64-0170	Cord Set w/plug (3 Prong) 18 Ga.
14	02-04-0970	Ball Bearing (Comm. End)
15	27-50-4481	Motor Housing (Includes item 9 and screws)
16	02-04-0940	Armature Ball Brg. (Pinion End)
17	28-28-0661	Diaphragm
18	02-50-1640	Needle Bearing
19	32-40-1241	Intermediate Gear
20	02-04-0640	Ball Bearing
21	36-66-2801	Pinion Shaft
22	36-66-2901	Pinion Shaft
23	34-60-1300	Spirolox Retaining Ring
24	45-88-0070	Collar Stop Washer

ILLUSTRATED PARTS

FIG.	PART NO.	DESCRIPTION OF PART
25	40-50-1000	Collar Stop Spring
26	02-04-1560	Ball Bearing
27	38-50-3501	Spindle
(2) 28	32-75-2061	Spindle Gear
(2) 29	32-75-2041	Spindle Gear
(2) 30	28-14-0961	Gear Case
31	02-50-2110	Needle Bearing
32	42-76-0090	Bit Retaining Collar
33	42-52-0080	Adapter Cap
34	45-22-0139	Sleeve
35	02-50-8820	Needle Bearing
36	44-68-0060	Adjustment Plug
37	44-90-0140	Ball Retaining Ring
38	06-65-0850	Type 2 Groove Pin
39	34-60-2000	Truarc Retaining Ring
40	42-76-0110	Clutch Collar
41	02-02-0340	Steel Balls
(2) 42	02-02-1000	Steel Ball 1" Dia.
43	42-66-0270	Chuck
44a	40-50-2600	Torque Limiting Spring Heavy
44b	40-50-2500	Torque Limiting Spring Light
45	45-24-0050	Slide
46	45-36-0210	Spindle Spacer
★ 47	02-02-0180	Steel Ball

MISCELLANEOUS PARTS NOT SHOWN

PART NO.	DESCRIPTION OF PART	PART NO.	DESCRIPTION OF PART
06-42-0800	Woodruff Keys	(3) 06-81-8625	Ground Screw (Brass) 6-32x1/4 Rd.Hd.
06-81-8400	4-40x1/4" Rd.Hd.Sems Name Plate Screws	(2) 06-81-6350	8-32x1" Fil.Hd. Gear Case Screws (Sem)
06-81-5800	6-32x5/16" Fil.Hd.Sems Switch Mtg. Screws	(2) 06-81-6600	8-32x1-3/4" Fil.Hd. Gear Case Scs.(Sem)
23-86-0110	Brush Holder Insulating Washer	(2) 06-81-6600	8-32x1-3/4" Fil.Hd. Field Screws (Sem)
23-16-0085	Switch Insulator	(2) 06-83-2650	1/4-20x3/8 Hdless. Brush Holder Set Screws
06-81-6150	8-32x1/2" Fil.Hd.Sems Cord Clamp Strap Scs.(2)	(4) 06-81-3700	8-32x7/8" Oval Hd. Handle Cover Screws
48-03-0010	Attachment Plug Adaptor		
★ 44-90-0160	Handle Ring Assy.		
★ 43-62-0160	Side Handle		