



SERVICE PARTS LIST

BULLETIN NO.
54-42-0060

SPECIFY CATALOG NO. AND SERIAL NO. WHEN ORDERING PARTS		REVISED BULLETIN	DATE
HEAVY-DUTY SCREW SHOOTER			May '83
CATALOG NO. 6627-1	STARTING SERIAL NO. 612-1001	WIRING INSTRUCTION	
CAT. NO. 6627-6	START SER. NO. 612-1001	58-01-0247	
		BILINGUAL LABEL 10-98-6400	

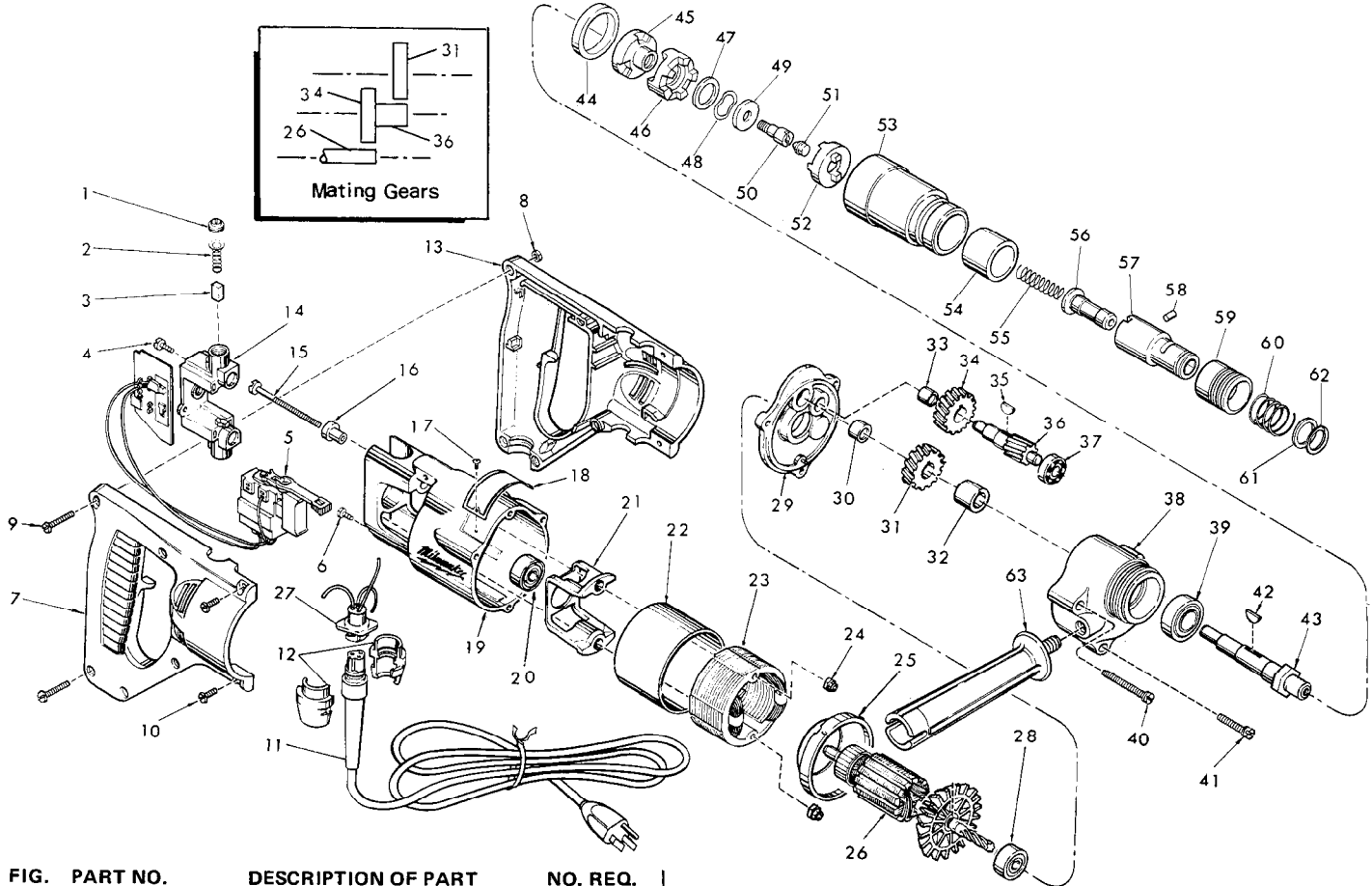

FIG.	PART NO.	DESCRIPTION OF PART	NO. REQ.
1	23-44-0120	Brush Retaining Screw	(2)
2	23-52-0160	Brush Spring	(2)
3	22-16-0250	Carbon Brush	(2)
4	06-95-0116	6-32 x 5/8" Pan Hd. Taptite Screw	(2)
5	23-66-1125	Switch	(1)
6	06-95-5150	Ground Screw	(1)
7	31-44-0630	R.H. Half D Handle	(1)
8	06-55-0835	8-32 Hex Nut	(5)
9	06-81-0473	8-32 x 1" Pan Hd. Pozidriv Screw	(5)
10	06-95-0700	8-32 x 1/2" Pan Hd. Taptite Screw	(4)
11	48-76-3008	Cord Set (Includes Fig. No. 12)	(1)
12	44-40-0440	Cord Nut	(2)
13	31-44-0640	L.H. Half D Handle	(1)
14	22-22-0302	Brush Holder Assembly	(1)
15	06-81-1055	8-32x2-3/16 Field Bolt	(2)
16	31-86-0120	Insulating Spacer	(2)
17	06-85-0200	6x1/4 Rd. Hd. Type Z Screw	(2)
18	12-99-0135	Nameplate Blank	(1)
19	28-50-6147	Motor Housing	(1)
20	02-04-0891	Ball Bearing	(1)
21	31-55-0030	Coil Shield	(1)
22	23-16-0456	Field Insulator	(1)
23	18-30-0100	120 V. Field	(1)
24	06-57-2975	8-32 Flexlock Hex Nut	(2)
25	31-05-0050	Baffle	(1)
26	16-30-0210	120 V. Armature	(1)
27	22-56-0391	Pin Housing Assy.	(1)
28	02-04-0940	Ball Bearing	(1)
29	28-28-0582	Diaphragm (Includes 06-65-0825 Pin)	(1)
30	02-50-2110	Needle Bearing	(1)
31	32-75-1601	Spindle Gear	(1)
32	45-36-0210	Spindle Gear Spacer	(1)
33	02-50-1640	Needle Bearing	(1)

FIG.	PART NO.	DESCRIPTION OF PART	NO. REQ.
34	32-40-1241	Intermediate Gear	(1)
35	06-42-0800	Woodruff Key	(1)
36	36-66-2001	Intermediate Shaft	(1)
37	02-04-0640	Ball Bearing	(1)
38	28-14-0689	Gear Case	(1)
39	02-04-1560	Ball Bearing	(1)
40	06-81-6707	8-32x1-7/8 Fil. Hd. Sem.	(2)
41	06-81-6402	8-32x1-1/8 Fil. Hd. Sem.	(1)
42	06-42-1600	Woodruff Key	(1)
43	38-50-3655	Spindle	(1)
44	44-86-0325	Bearing Retainer	(1)
45	42-04-0611	Clutch Adapter	(1)
46	42-70-5040	Drive Clutch	(1)
47	45-88-0070	Collar Stop Washer	(1)
48	45-88-7115	Wave Washer	(1)
49	45-88-0870	Washer	(1)
50	45-04-0540	Special Screw	(1)
51	44-60-0540	Thrust Pin	(1)
52	42-70-5035	Driven Clutch	(1)
53	43-76-0410	Clutch Housing	(1)
54	02-50-6435	Roller Bearing	(1)
55	40-50-7740	Separator Spring	(1)
56	43-84-0481	Bearing Insert	(1)
57	42-66-6761	Chuck Shaft	(1)
58	02-55-0160	Roller Bearing - Loose	(1)
59	42-76-0240	Locking Collar	(1)
60	40-50-7730	Spring	(1)
61	45-88-0860	Washer	(1)
62	34-60-1575	Retaining Ring	(1)
63	43-62-0605	Side Handle	(1)
64	10-98-5987	Warning Label (Not Shown) Omit For Canadian Tools	(1)

MILWAUKEE ELECTRIC TOOL CORPORATION
13135 W. LISBON RD., BROOKFIELD, WIS. 53005