



SERVICE PARTS LIST

BUL. 54-42-4002

SCREWDRIVER

REVISED BUL 634-4 DATE Feb. '68
WIRING INSTR.

Catalog No. 6620

Starting Serial No. **34-2351**

Both Model and Serial No. must be furnished to obtain correct parts.

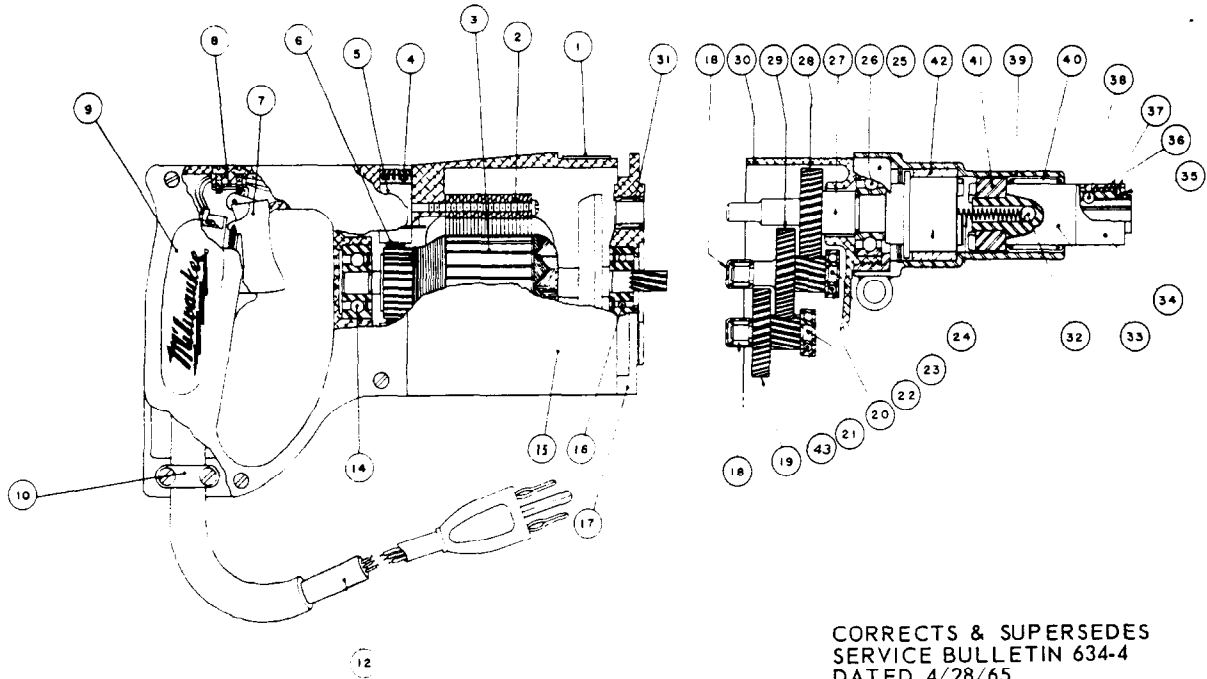

CORRECTS & SUPERSEDES SERVICE BULLETIN 634-4 DATED 4/28/65

ILLUSTRATED PARTS

FIG.	PART NO.	DESCRIPTION OF PART
1	12-98-0800	Name Plate
2	18-42-1160	Field Assembly
3	16-42-1210	Armature Assembly
4	23-44-0060	Brush Retaining Screw
5	22-22-0080	Brush Holder Assembly
6	22-18-0100	Carbon Brush Assemblies
7	23-66-0230	Switch
8	45-36-0110	Switch Spacer
9	28-20-3141	Handle Cover
10	28-17-0400	Cord Clamp Strap
12	22-64-0170	Cord Set
14	02-04-0970	Ball Bearing (Comm. End)
15	27-50-4481	Motor Housing (Includes item 9 and screws)
16	02-04-0940	Ball Bearing (Pinion End)
17	28-28-0661	Diaphragm
18	02-50-1640	Needle Bearing
19	32-40-1241	Intermediate Gear
20	02-04-0820	Ball Bearing
21	36-66-2801	Intermediate Pinion Shaft
22	36-66-4001	Intermediate Pinion Shaft

FIG.	PART NO.	DESCRIPTION OF PART
23	43-90-0060	Driving Jaw
24	40-50-0900	Separating Spring
25	42-52-0071	Bearing Cap
26	02-04-1560	Ball Bearing
27	38-50-3601	Spindle
28	32-75-2061	Spindle Gear
29	32-75-2041	Spindle Gear
30	28-14-1261	Gear Case
31	02-50-2110	Needle Bearing
32	02-02-0250	Ball
33	42-66-0165	Chuck Assembly
34	42-76-0090	Bit Retaining Collar
35	34-60-1300	Collar Stop Washer Retaining Ring
36	45-88-0070	Collar Stop Washer
37	40-50-1000	Collar Stop Spring
38	02-02-0180	Bit Retaining Ball
39	02-50-6440	Needle Bearing
40	45-22-0070	Sleeve Assembly
41	43-90-0050	Chuck Jaw
42	42-24-0080	Driving Jaw Bearing
*43	02-04-0640	Ball Bearing

MISCELLANEOUS PARTS NOT SHOWN

PART NO.	DESCRIPTION OF PART
34-80-2800	Driving Jaw Retaining Ring
43-62-0161	Handle
48-30-3250	Bit and Finder
48-30-3275	Bit and Finder
48-30-3300	Bit and Finder
48-32-2070	Square Driver (for Sockets)
06-75-0500	3/8"-16x1" Long Cap Screw
49-96-4060	Open End Wrench
06-42-0800	Woodruff Keys
06-81-8400	4-40x1/4" Rd. Hd. Name Plate Screws

PART NO.	DESCRIPTION OF PART
06-81-5800	6-32x5/16" Fil. Hd. Sems Switch Mtg. Screws (2)
23-86-0110	Brush Holder Insul. Washer (2)
23-16-0050	Switch Insulator
06-81-6100	8-32x7/16 Fil. Hd. Sem Cord Clamp Strap Scs. (2)
06-81-8625	6-32x1/4" Rd. Hd. Ground Screw (Brass)
06-81-6350	8-32x1" Fil. Hd. Gear Case Screws (Sem) (2)
06-81-6650	8-32x1-3/4" Fil. Hd. Gear Case Screws (Sem) (2)
06-81-6600	8-32x1-3/4" Fil. Hd. Field Screws (Sem) (2)
06-83-2650	1/4"-20x3/8" Hd. less Brush Holder Set Scs. (2)
06-81-3700	8-32x7/8" Oval Hd. Handle Cover Screws (4)