



SERVICE PARTS LIST

BUL.54-42-0602

SCREWDRIVER

REVISED BUL. 54-42-0602 DATE March '70

Catalog No. 6541-1

Starting Serial No. **388-1736**

WIRING INSTR. **58-01-0640**

Both Model and Serial No. must be furnished to obtain correct parts.

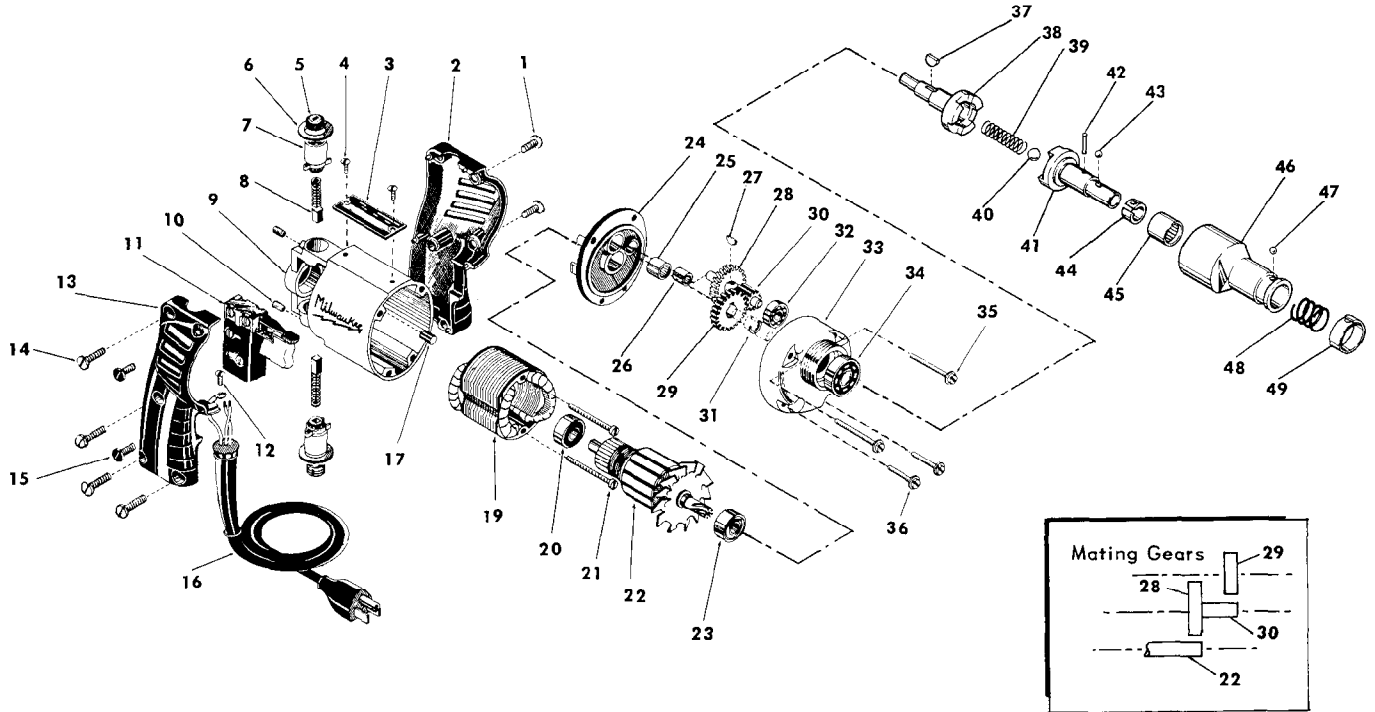

FIG.	PART NO.	DESCRIPTION OF PART	NO.REQ.	FIG.	PART NO.	DESCRIPTION OF PART	NO.REQ.
1	06-81-0450	8-32 x 3/8 Pan Hd. Screw	(2)	26	02-50-1210	Needle Bearing	
2	31-44-0260	L. H. Handle Half		27	06-42-0400	Woodruff Key	
3	12-98-0600	Name Plate		28	32-40-1121	Intermediate Gear	
4	06-77-0625	6 x 1/4 Rd. Hd. Driv-in Screw	(2)	29	32-75-1121	Spindle Gear	
5	23-44-0020	Brush Retaining Cap	(2)	30	36-66-0851	Intermediate Pinion Shaft	
6	23-86-0070	Insulating Washer	(2)	31	34-60-0600	Spindle Snap Ring	
7	22-22-0251	Brush Holder Assy. (incl. fig. 6)	(2)	32	02-04-0640	Ball Bearing	
8	22-18-0360	Carbon Brush Assy.	(2)	33	28-14-0361	Gear Case	
9	28-50-6091	Motor Housing (incl. fig. 17)		34	02-04-1020	Ball Bearing	
10	06-83-2430	10-32 x 1/4 Soc. Hd. Set Screw	(2)	35	06-81-6550	8-32 x 1/2 Fil. Hd. Sem Gear Case Scrs. (2)	
11	23-66-0810	Reversing Switch (see fig. 18)		36	06-81-6300	8-32 x 7/8 Fil. Hd. Sem Gear Case Srs. (2)	
12	06-81-8625	6-32 x 1/4 (Bronze) Rd. Hd. Ground Scrs.		37	06-42-0800	Woodruff Key	
13	31-44-0250	R. H. Handle Half		38	38-50-2301	Spindle	
14	06-81-0400	8-32 x 3/4 Pan Hd. Screw	(4)	39	40-50-2000	Separating Spring	
15	06-81-0450	8-32 x 3/8 Pan Hd. Screw	(2)	40	02-02-0310	5/16 Steel Ball	
16	22-64-0660	Cord Set		41	42-66-0240	Chuck (incl. fig. 42)	
17	45-30-0120	Ball Bearing Ret. Slug		42	06-65-1534	1/8 x 5/8 Roll Pin	
18	06-97-1700	Lock Washer For Switch (not shown)	(8)	43	02-02-0150	5/32 Steel Ball	
19	18-22-1121	Field Assembly		44	40-50-1400	Bit Retaining Spring	
20	02-04-0740	Ball Bearing		45	02-50-3640	Needle Bearing	
21	06-81-5950	6-32 x 1-7/8 Fil. Hd. Field Screws	(2)	46	45-22-0100	Sleeve	
22	16-22-1241	Armature Assy.		47	02-02-0150	5/32 Steel Ball	
23	02-04-0740	Ball Bearing		48	40-50-1900	Finder Spring	
24	28-28-0221	Diaphragm		49	40-50-1800	Finder Retaining Spring	
25	02-50-1640	Needle Bearing					