



SERVICE PARTS LIST

BULLETIN NO.
54-40-5059

SPECIFY CATALOG NO. AND SERIAL NO. WHEN ORDERING PARTS		REVISED BULLETIN 54-40-5058	DATE May '98
SUPER SAWZALL®			
CATALOG NO. 6528	STARTING SERIAL NUMBER	775F	
		WIRING INSTRUCTION 58-01-0781	

EXAMPLE:
 00-0 Component Parts (Small #)
 Are Included When Ordering
 The Assembly (Large #).

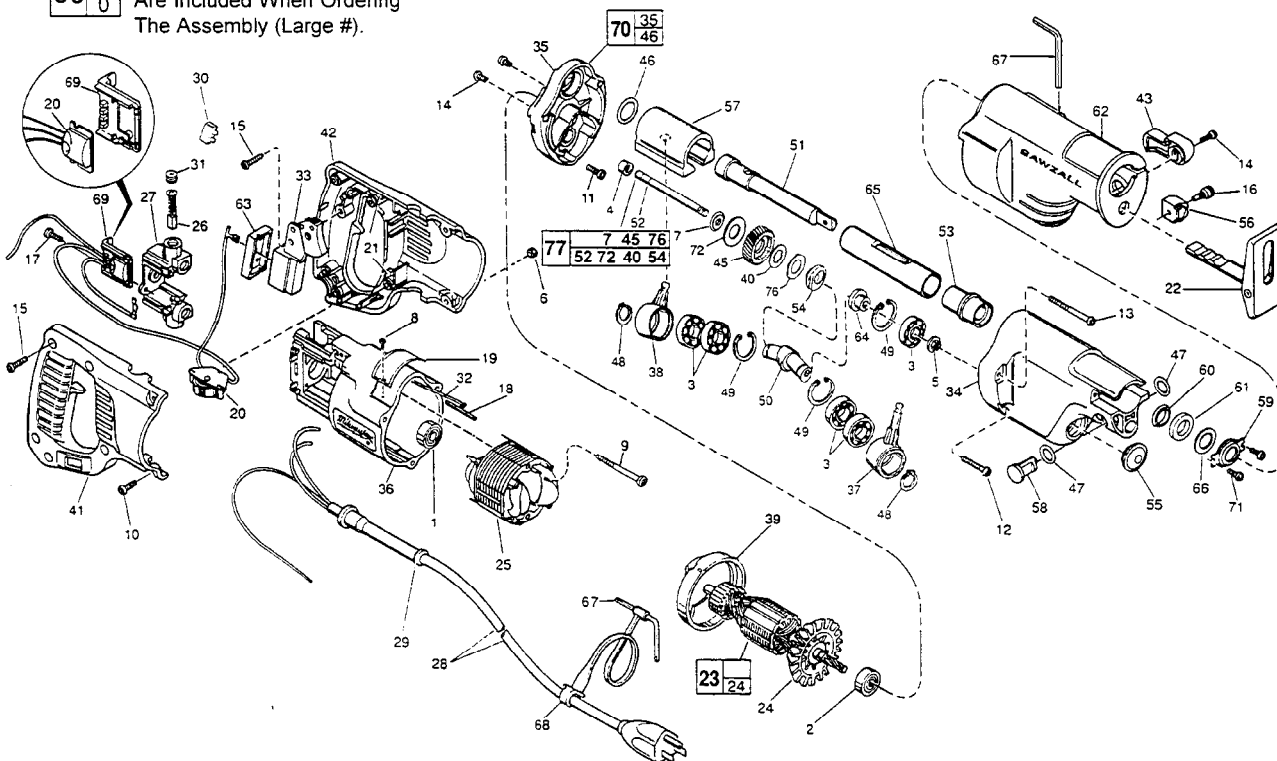
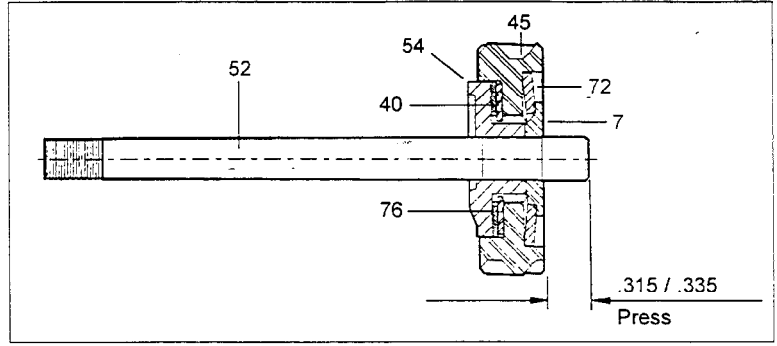

FIG.	PART NO.	DESCRIPTION OF PART	QTY.	FIG.	PART NO.	DESCRIPTION OF PART	QTY.
1	02-04-0845	Ball Bearing	(1)	43	31-52-0010	Shoe Release Lever	(1)
2	02-04-0911	Ball Bearing	(1)	★ 45	32-40-2095	Gear	(1)
3	02-04-1510	Ball Bearing	(5)	46	34-40-1280	O-Ring	(1)
4	02-50-2150	Needle Bearing	(1)	47	34-40-4200	O-Ring	(2)
5	06-55-3790	Spinlock Hex Nut 5/16-24	(1)	48	34-60-1315	Ext. Retaining Ring	(2)
6	06-55-0835	8-32 Hex Nut	(2)	49	34-80-2600	Internal Retaining Ring	(3)
★ 7	43-78-0530	Spring Retainer	(1)	50	36-92-0701	Wobble Shaft	(1)
8	06-72-1710	Nameplate Rivet	(2)	51	38-50-5331	Reciprocating Spindle	(1)
9	06-82-7410	8-16 x 1-7/8" Pan Hd. Plastite T-20	(2)	52	42-12-0150	Axle - Wobble Shaft	(1)
10	06-82-2390	8-32 x 1-1/4" Pan Hd. Slit. T-20	(2)	53	42-24-0430	Spindle Bearing	(1)
11	05-88-8307	K50 x 22mm Pan Hd. PT T-20	(1)	★ 54	43-78-0525	Drive Hub	(1)
12	06-82-5390	8-32 x 1-1/4" Pan Hd. Slit. Tapt. T-20	(2)	55	42-52-0380	Bearing Cap	(1)
13	05-88-8301	K50 x 60mm Pan Hd. PT T-20	(2)	56	42-68-0677	Blade Clamp	(1)
14	06-82-7252	8-32 x 3/8" Pan Hd. Slit. Tapt. T-20	(3)	57	42-87-0090	Counter Balance	(1)
15	06-82-7270	8-16 x 5/8" Pan Hd. Slit. Plas. T-20	(6)	58	44-60-1200	Lock Pin	(1)
16	06-83-2960	Blade Clamp Screw	(1)	59	44-86-0375	Seal Retainer	(1)
17	06-82-7240	6-19 x 1/2" Pan Hd. Slit. Plastite T-15	(2)	60	45-06-0475	Polypak Seal	(1)
18	44-60-0530	Ground Pin	(1)	61	45-06-0500	Felt Seal	(1)
19	12-99-1735	Service Nameplate	(1)	62	45-12-0460	Gear Case Insulator	(1)
20	14-20-3020	Remote Dial Assembly	(1)	63	45-12-0470	Dust Shield	(1)
21	14-46-1001	Foam Slug Kit - 10 Slugs	(2)	64	45-36-1450	Spacer	(1)
22	14-74-0270	Shoe Assembly	(1)	65	45-76-0320	Tube Chassis	(1)
23	16-30-0565	120 V. Armature	(1)	66	45-88-8576	Washer	(1)
24	22-84-0531	Fan Assembly	(1)	67	49-96-0090	3/16" Allen Wrench	(2)
25	18-31-0500	120 V. Field	(1)	68	48-66-4080	Key Holder	(1)
26	22-18-0910	Carbon Brush Assembly	(2)	69	43-72-0176	Heat Sink Holder	(1)
27	22-22-1380	Brush Holder Assembly	(1)	70	28-28-2000	Diaphragm Assembly	(1)
28	22-64-0155	Cord Set	(1)	71	06-95-0075	6-32 x 3/8" Truss Hd. Taptite Screw	(2)
29	44-76-0210	Cord Protector	(1)	★ 72	40-50-8850	Disc Spring	(1)
30	22-56-0456	Terminal Block	(1)	★ 76	43-06-0675	Bronze Disc	(1)
31	23-44-0190	Brush Retaining Cap	(2)	★ 77	32-40-2101	IPS Gear Assembly	(1)
32	23-94-6100	Ground Wire Assembly	(1)				
33	23-66-1490	Switch	(1)				
34	28-14-2176	Gear Case	(1)				
35	28-28-1876	Diaphragm	(1)				
36	31-50-0020	Motor Housing	(1)				
37	30-72-0082	Primary Wobble Plate	(1)				
38	30-72-0092	Secondary Wobble Plate	(1)				
39	31-05-0055	Baffle	(1)				
★ 40	43-06-0685	Metal Disc	(1)				
41	31-44-1651	Right Handle Half	(1)				
42	31-44-1656	Left Handle Half	(1)				

**SEE REVERSE SIDE FOR
IMPORTANT SERVICE NOTES**

MILWAUKEE ELECTRIC TOOL CORPORATION
 13135 W. Lisbon Road, Brookfield, WI 53005
 Drwg. 1

- FIG. 1** **NOTES:**
- 1 Seal side faces commutator.
 - 2 Seal side faces fan.
 - 4 Press flush to diaphragm surface - Mechanism side.
 - 40, 45 Apply a thin coat of type "N" grease (Cat. No. 49-08-4230) between gear and metal disc.
 - 40 Tabs engage drive hub.
 - 76 Tabs engage gear.
 - 72 Concave towards gear.
 - 45, 52 See sketch for press specifications.



- 5 Apply thread locking compound to threads of spinlock hex nut. Torque to 145 in./lbs. to 185 in./lbs.
- 5, 45 Hold the gear still with a large pair of pliers and a piece of rubber hose (or other tough, but pliable material to protect the gear from the jaws of the pliers) and remove the 5/16" spinlock hex nut with a wrench, as shown.
- 50, 54 Make sure that the end of the wobble shaft fits into the offset (eccentric) recess, as shown.
- 34 Place 2-3/4 oz. of type "L" grease (Cat. No. 49-08-4175), in mechanism cavity of gear case.
- 35 Place 3/4 oz. of type "N" grease (Cat. No. 49-08-4230), in lower needle bearing-gear train cavity of diaphragm.

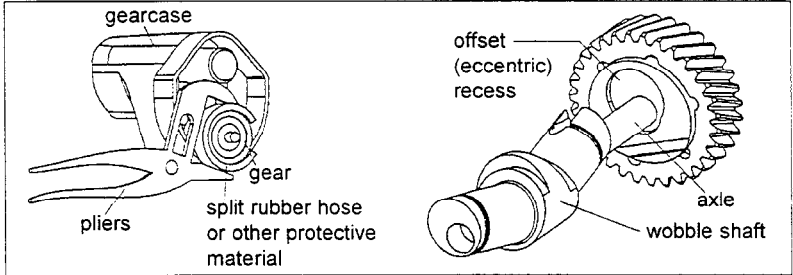

- 37,38,49 Internal retaining ring side faces center hub of wobble shaft.
- 46 Replace each time gear case mechanism is serviced. O-ring opening of diaphragm and rear of tube chassis must be free of all grease prior to o-ring installation.
- 49 Sharp side of retaining ring faces ball bearing.

- 56 Tab end faces forward - toward shoe assembly (Lessens blade breakage).

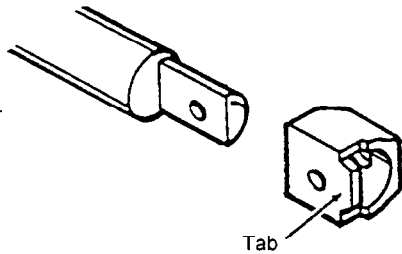

- 60 O-ring of polypak seal faces mechanism - toward rear of tool.
- 61 Soak in lightweight lubricating oil prior to assembly.
- 63 Non-conductive insulation of wires must pass through rubber dust shield; Provides proper sealing of switch from contamination.
- 65 Assembled with large O.D. chamfered end facing diaphragm- can be slip or press fit on spindle bearing.