



# SERVICE PARTS LIST

**BULLETIN NO.**  
54-40-4256

SPECIFY CATALOG NO. AND SERIAL NO. WHEN ORDERING PARTS		REVISED BULLETIN 54-40-4255	DATE June '84
<b>TWO SPEED SAWZALL</b>			
<b>CATALOG NO. 6511</b>		<b>STARTING SERIAL NO. 460-700000</b>	
<b>WIRING INSTRUCTION 58-01-0245</b>			
CAT. NO.	START SER. NO.	BILINGUAL LABEL	

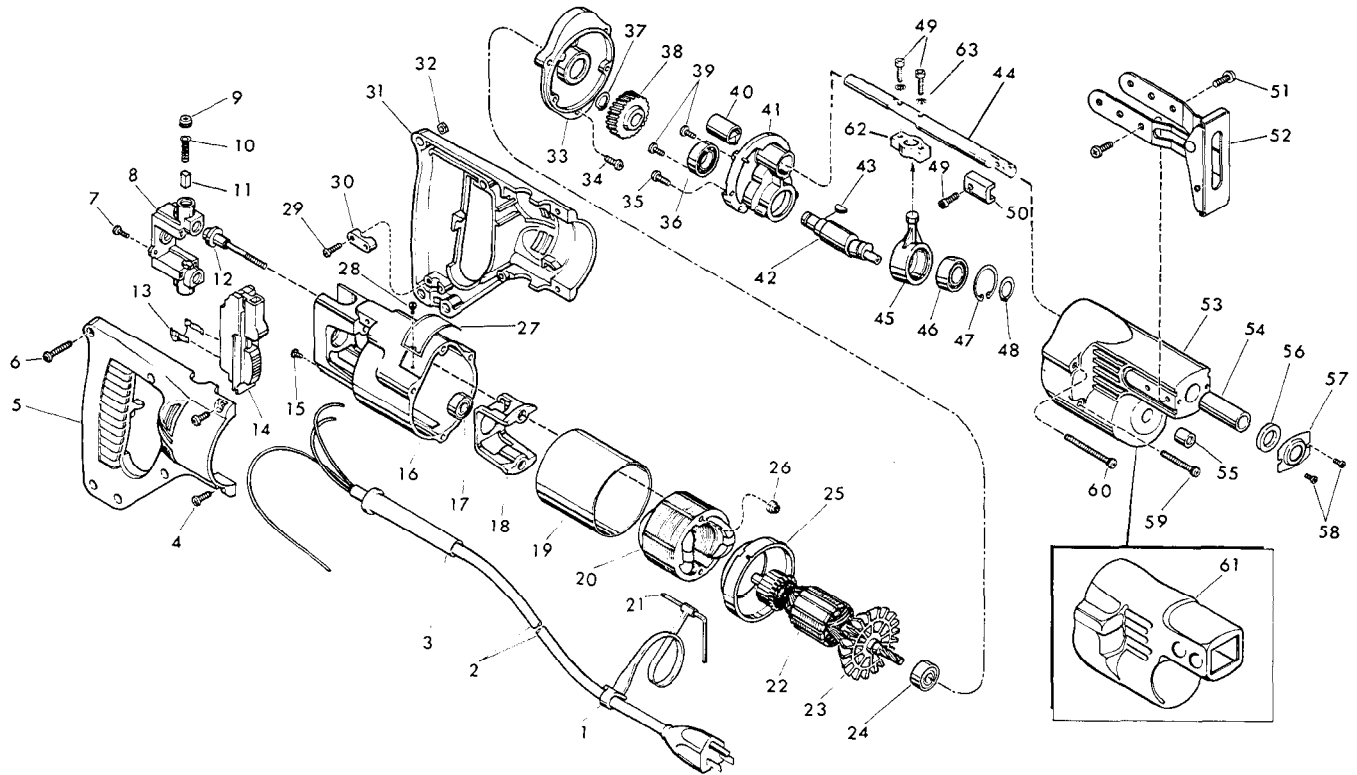

FIG.	PART NO.	DESCRIPTION OF PART	NO. REQ.	FIG.	PART NO.	DESCRIPTION OF PART	NO. REQ.
	1	48-66-4080 Key Holder	(1)	★ 37	34-60-0920	Retaining Ring - External (See Note)	(1)
★	2	22-64-0155 Cord Set	(1)	★ 38	32-40-1920	Intermediate Gear	(1)
★	3	44-76-0150 Cord Protector	(1)	★ 39	06-95-0075	6-32 x 3/8 Truss Hd. Taptite Screw	(2)
★	4	06-95-0700 8-32 x 1/2 Pan Hd. Taptite Screw	(4)	★ 40	42-24-0250	Spindle Bearing - Rear	(1)
★	5	31-44-1300 R.H. Half - D Handle	(1)	★ 41	28-72-1002	Bearing Plate Assy. (Includes 06-65-0825 Groove Pin)	(1)
★	6	06-81-0473 8-32 x 1 Pan Hd. Pozi Drive Screw	(5)	★ 42	36-92-0670	Wobble Shaft	(1)
★	7	06-95-0075 6-32 x 3/8 Truss Hd. Taptite Screw	(2)	43	06-42-1200	Woodruff Key	(1)
★	8	22-22-1330 Brush Holder Assembly	(1)	44	38-50-2002	Reciprocating Spindle	(1)
★	9	23-44-0190 Brush Retaining Cap	(2)	★ 45	30-72-0060	Wobble Plate	(1)
10	23-52-0160	Brush Spring	(2)	46	02-04-1510	Ball Bearing	(1)
★ 11	22-16-0275	Carbon Brush	(2)	47	34-80-2355	Retaining Ring - Internal (See Note)	(1)
★ 12	06-81-1058	Insulated Field Bolt	(2)	48	34-60-1200	Retaining Ring - External (See Note)	(1)
13	23-38-2790	Diode	(1)	49	06-75-2400	10-32 x 1/2 Skt. Hd. Screw	(3)
14	23-66-1040	Switch	(1)	50	42-68-0073	Blade Clamp	(1)
★ 15	06-95-5150	6-32 x 1/4 Hex Hd. Taptite Sem	(1)	★ 51	06-95-0800	10-24 x 1/2 Pan Hd. Taptite Screw	(4)
★ 16	28-50-6200	Motor Housing	(1)	★ 52	45-16-0495	Pivot Shoe Assembly	(1)
★ 17	02-04-0845	Ball Bearing	(1)	★ 53	28-14-1615	Gear Case	(1)
18	31-55-0030	Coil Shield	(1)	54	42-24-0095	Spindle Bearing - Front (See Note)	(1)
19	23-16-0456	Field Insulator	(1)	55	02-50-1640	Needle Bearing	(1)
20	18-30-0300	120V Field	(1)	★ 56	45-06-0300	Felt Seal	(1)
21	49-96-0070	5/32" Socket Wrench	(1)	★ 57	44-86-0370	Seal Retainer	(1)
★ 22	16-30-0425	120V Armature (Includes Fig. No. 23)	(1)	★ 58	06-95-0050	4-40 x 3/16 Pan Hd. Taptite Screw	(2)
23	22-84-0530	Fan Assembly	(1)	★ 59	06-81-1005	8-32 x 1-3/8 Fil. Hd. Sem. Screw	(2)
★ 24	02-04-0911	Ball Bearing	(1)	★ 60	06-81-1010	8-32 x 1-7/8 Fil. Hd. Sem. Screw	(2)
25	31-05-0050	Baffle	(1)	61	45-12-0300	Gear Case Insulator	(1)
★ 26	06-57-2975	8-32 Flexlock Hex Nut	(2)	62	30-10-1030	Spindle Block	(1)
★ 27	12-99-0360	Nameplate Blank	(1)	63	06-97-3400	Lock Washer	(2)
28	06-85-0200	Nameplate Screw	(2)				
★ 29	06-95-0216	8-16 x 5/8 Plastite Screw	(2)				
★ 30	31-17-0156	Cord Clamp	(1)				
★ 31	31-44-1305	L.H. Half - D Handle	(1)				
★ 32	06-55-0835	8-32 Hex Nut	(5)				
33	28-28-0342	Diaphragm	(1)				
★ 34	06-81-0919	8-32 x 5/8 Fil. Hd. Sem Screw	(1)				
★ 35	06-81-0905	8-32 x 1/2 Fil. Hd. Sem Screw (See Note)	(2)				
36	02-04-1510	Ball Bearing	(1)				

**FIG. NOTES**

- 35 Apply Type 242 Blue Loctite
- 37, 47, 48 Burr Side Out
- 40 V-Notch Press In From Diaphragm Side

**LUBRICATION**

- 2-1/2 Oz. Type "B" Lubricant - Gear Case
- 1/2 Oz. Type "A" Lubricant - Bearing Plate/Intermediate Gear