



SERVICE PARTS LIST

BULLETIN NO.
54-40-0103

SPECIFY CATALOG NO. AND SERIAL NO. WHEN ORDERING PARTS		REVISED BULLETIN 54-40-0102	DATE Jan. '85
TRIGGER SPEED CONTROL SAWZALL			
CATALOG NO. 6507		STARTING SERIAL NO. 631-220000	
		WIRING INSTRUCTION 58-01-0249	
CAT. NO.	START SER. NO.	BILINGUAL LABEL	

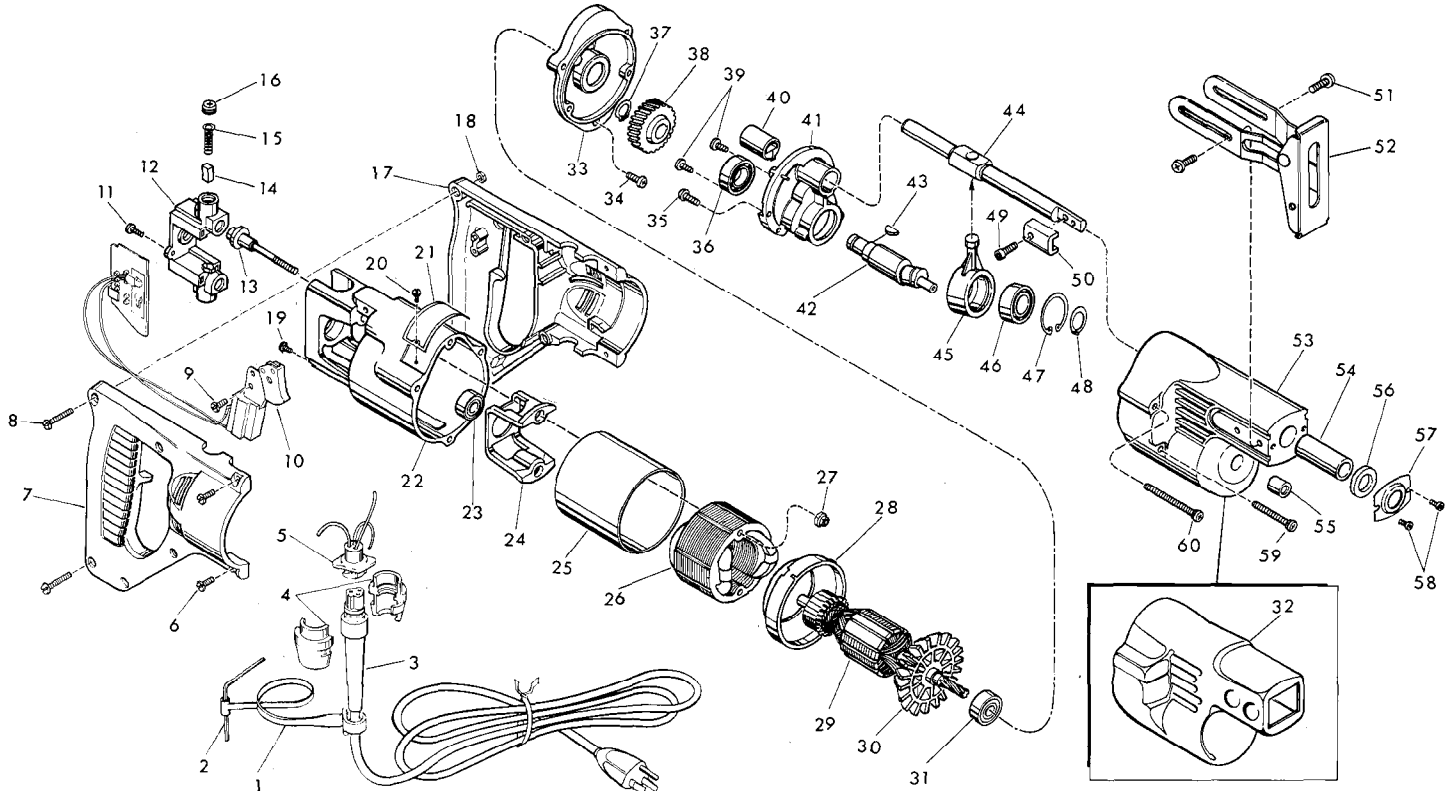

FIG.	PART NO.	DESCRIPTION OF PART	NO. REQ.
	1	48-66-4080 Key Holder	(1)
	2	49-96-0070 5/32" Socket Wrench	(1)
	3	48-76-3008 Cord Set (Includes Fig. No. 4)	(1)
	4	44-40-0440 Cord Nut	(2)
	5	22-56-0391 Pin Housing Assembly	(1)
	6	06-95-0700 8-32 x 1/2" Pan Hd. Taptite Screw	(4)
	7	31-44-0582 R.H. Half D Handle	(1)
	8	06-81-0473 8-32 x 1" Pan Hd. Pozidriv Screw	(5)
	9	06-95-0215 8-18 x 1/2" Thread Form Screw	(1)
	10	23-66-0955 Speed Control Switch	(1)
	11	06-95-0075 6-32 x 3/8" Truss Hd. Taptite Screw	(2)
	12	22-22-1330 Brush Holder Assembly	(1)
	13	06-81-1058 Insulated Field Bolt	(2)
	14	22-16-0275 Carbon Brush	(2)
	15	23-52-0160 Brush Spring	(2)
	16	23-44-0190 Brush Retaining Cap	(2)
	17	31-44-0592 L.H. Half D Handle	(1)
	18	06-55-0835 8-32 Hex Nut	(5)
	19	06-95-5150 6-32 x 1/4" Hex Hd. Taptite Sem.	(1)
	20	06-85-0200 Nameplate Screw	(2)
	21	12-99-0360 Nameplate Blank	(1)
★	22	28-50-6201 Motor Housing	(1)
	23	02-04-0845 Ball Bearing	(1)
	24	31-55-0030 Coil Shield	(1)
	25	23-16-0456 Field Insulator	(1)
	26	18-30-0300 120V Field	(1)
	27	06-57-2975 8-32 Flexlock Hex Nut	(2)
	28	31-05-0050 Baffle	(1)
	29	16-30-0425 120V. Armature (Incl. Fig. No. 30)	(1)
	30	22-84-0530 Fan Assembly	(1)
	31	02-04-0911 Ball Bearing	(1)
	32	45-12-0300 Gear Case Insulator	(1)
★	33	28-28-0345 Diaphragm	(1)
★	34	06-82-0015 8-32 x 5/8 Fil. Hd. Sem Screw	(1)
★	35	06-82-0020 8-32 x 1/2 Fil. Hd. Sem Screw (See Note)	(2)
	36	02-04-1510 Ball Bearing	(1)
	37	34-60-0920 Retaining Ring - External (See Note)	(1)

FIG.	PART NO.	DESCRIPTION OF PART	NO. REQ.
	38	32-40-1920 Intermediate Gear	(1)
	39	06-95-0075 6-32 x 3/8 Truss-Hd. Taptite Screw	(2)
	40	42-24-0250 Spindle Bearing - Rear (See Note)	(1)
	41	28-72-1002 Bearing Plate	(1)
	42	36-92-0670 Wobble Shaft	(1)
	43	06-42-1200 Woodruff Key	(1)
★	44	38-50-5410 Reciprocating Spindle	(1)
	45	30-72-0060 Wobble Plate	(1)
	46	02-04-1510 Ball Bearing	(1)
	47	34-80-2355 Retaining Ring - Internal (See Note)	(1)
	48	34-60-1200 Retaining Ring - External (See Note)	(1)
	49	06-75-2400 10-32 x 1/2 Skt. Hd. Screw	(1)
	50	42-68-0073 Blade Clamp	(1)
★	51	06-95-6270 10-24 x 1/2 Pan Hd. Taptite Sems	(4)
	52	45-16-0495 Pivot Shoe Assembly	(1)
★	53	28-14-0575 Gear Case	(1)
	54	42-24-0095 Spindle Bearing - Front (See Note)	(1)
	55	02-50-1640 Needle Bearing	(1)
	56	45-06-0300 Felt Seal	(1)
	57	44-86-0370 Seal Retainer	(1)
	58	06-95-0050 4-40 x 3/16 Pan Hd. Taptite Screw	(2)
★	59	06-95-5260 8-32 x 1-3/8 Fil. Hd. Sem Screw	(2)
★	60	06-95-5270 8-32 x 1-7/8 Fil. Hd. Sem. Screw	(2)

FIG. NOTES

- 35 Apply Type 242 Blue Loctite
- 37, 47, 48 - Burr Side Out
- 40 V-Notch Press In From Diaphragm Side
- 54 Press to 1/32" Below Surface

LUBRICATION

- 2-1/2 Oz. Type "B" Lubricant - Gear Case
- 1/2 Oz. Type "A" Lubricant - Bearing Plate/Intermediate Gear

MILWAUKEE ELECTRIC TOOL CORPORATION
13135 W. LISBON RD., BROOKFIELD, WIS. 53005