



# Assembly Instructions and Parts List

## Open Stand with Shelf

Stock Number: 638004

For use with Sander models 10-20 Plus, 16-32 and 16-32 Plus



### Replacement Parts

To order parts or reach our service department, call 800-274-6848 Monday through Friday (see our website for business hours). Having the Model Number and Serial Number of your product available when you call will allow us to serve you quickly and accurately.

### Parts

Index No.	Part No.	Description	Size	Qty
1A	40-4040	Left Leg		2
1B	40-4041	Right Leg (with TufTool holder)		2
2	40-4042	Long Rail		2
3	40-4043	Short Rail		2
4	40-4044	Shelf		1
5	10-1206	Carriage Bolt	5/16"x5/8"	24
6	12-0207	Flanged Lock Nut	5/16"	24
7	20-0655	Leveling Foot		4
8	12-0005	Hex Nut	3/8"	8
9	11-9103	Flat Washer	3/8"	8

**JET**  
427 New Sanford Road  
LaVergne, Tennessee 37086  
Ph.: 800-274-6848  
www.jettools.com

**Manual No. 92-6082**  
Revision G2 01/2014  
Copyright © 2014 JET

## Assembly

*Tools required:* 1/2" and 9/16" wrenches

Reference numbers correspond to the exploded drawing below.

1. Assemble legs (1A and 1B) to outside of Short Rails (3) using carriage bolts (5) and lock nuts (6). Finger tighten only.
2. Assemble Long Rail (2) on inside of legs (1A and 1B) and on top of Short Rails (3). Finger tighten only. NOTE: Flange of Long Rail (2) overlaps flange of Short Rails (3) – see detail drawing below.
3. Turn stand upside down. Install shelf (4) into legs using carriage bolts (5) and lock nuts (6). Fully tighten all nuts in shelf and legs.
4. Install leveling foot (7) (or optional casters) in bottom hole of leg (1A & 1B) by placing hex nut (8) and flat washer (9) above and below leg flange to allow leveling of stand to an uneven surface.
5. Turn stand right-side up.

6. Place your sander on the stand so holes of sander base align with holes in flange of long rails (2). Fasten sander to stand, from bottom up, using the hex cap screws (X) and washers (Y) that were included with your sander packaging.

NOTE: When mounting the 10-20 Sander, the Foot Plate must be reversed in order to mount to the stand (Figure 1).

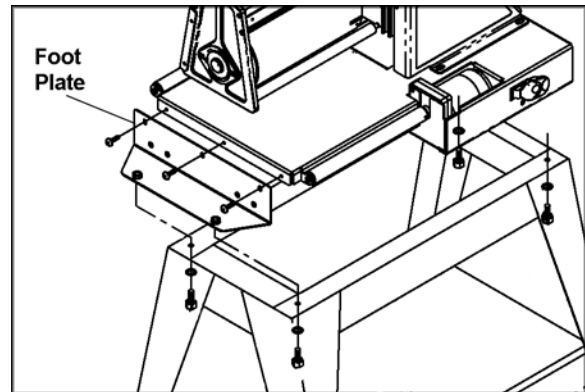

Figure 1 (model 10-20 only)

