



SERVICE PARTS LIST

BULLETIN NO.
54-40-5400

SPECIFY CATALOG NO. AND SERIAL NO. WHEN ORDERING PARTS		REVISED BULLETIN	DATE
7-1/4" CIRCULAR SAW			June '99
CATALOG NO.	6375-20	STARTING SERIAL NO.	961A
		WIRING INSTRUCTION	58-01-0754

EXAMPLE:

00 0 Component Parts (Small #) Are Included
When Ordering The Assembly (Large #).

FIG.	PART NO.	DESCRIPTION OF PART	NO. REQ.
1	06-75-0477	3/8-24 Blade Screw	(1)
2	45-88-0286	Outer Blade Flange	(1)
3	43-34-0560	Inner Blade Flange	(1)
4	34-60-2195	External Retaining Ring	(1)
5	06-82-5317	8-32 x 1/2" Pan Hd. Taptite T-20	(3)
6	43-62-0910	Lower Guard Handle	(1)
7	28-41-0913	Lower Guard	(1)
8	45-14-0230	Lower Guard Shim	(1)
9	40-50-4510	Lower Guard Spring	(1)
10	06-95-3241	8-32 x 1/2" Phil. Flat Hd. Taptite	(4)
11	28-53-0260	Hub	(1)
12	06-82-7395	8-16 x 1-3/4" Pan Hd. Plastite T-20	(6)

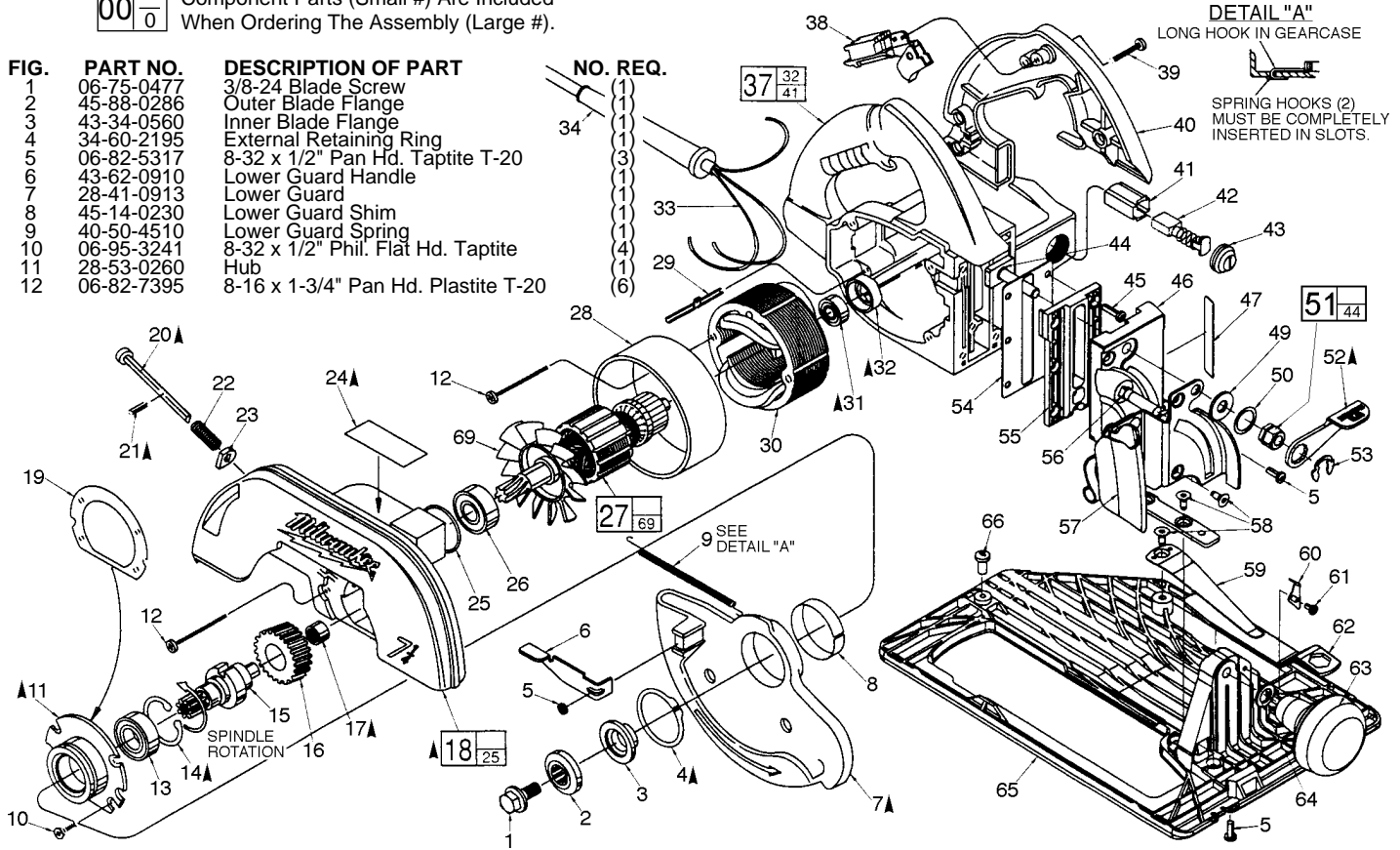

13	02-04-1701	Ball Bearing	(1)
14	34-80-2365	Internal Retaining Ring	(1)
15	38-50-5605	Spindle	(1)
16	32-75-3205	Gear	(1)
17	02-50-2423	Roller Bearing	(1)
18	14-30-0482	Upper Guard Gearcase Assembly	(1)
★ 19	43-44-0801	Gasket	(1)
20	45-08-0200	Spindle Lock Shaft	(1)
21	06-65-1534	1/8 x 5/8 Roll Pin	(1)
22	40-50-8040	Lock Shaft Spring	(1)
23	45-88-8250	Felt Washer	(1)
24	12-20-0176	Service Nameplate Kit	(1)
25	34-40-4140	O-Ring	(1)
26	02-04-1700	Ball Bearing	(1)
27	16-70-0305	Armature	(1)
28	42-14-0310	Baffle	(1)
29	44-60-0530	Ground Pin	(1)
30	18-70-0045	Field	(1)
31	02-04-0850	Ball Bearing	(1)
32	42-96-0130	Bearing Cup	(1)
33	22-64-0015	Cord Set	(1)
34	44-76-0050	Cord Strain Relief	(1)
37	31-50-1041	Motor Housing Assembly	(1)
38	23-66-2110	Switch	(1)
39	06-82-7299	8-16 x 7/8" Pan Hd. Slit. Plastite T-20	(4)
40	31-44-1422	Handle Half	(1)
41	22-20-0820	Brush Tube	(2)
42	22-18-0550	Carbon Brush Assembly	(2)
43	23-44-0160	Brush Retaining Screw	(1)
★ 44	-----	Twin Lead Adjusting Stud (See Fig. 51)	(1)
45	06-82-7270	8-16 x 5/8" Pan Hd. Slit. Plastite T-20	(6)
46	25-10-0100	Vertical Bracket	(1)
47	43-82-0040	Vertical Scale	(1)
49	45-88-8460	5/16 Washer	(1)
50	45-88-0577	Wave Washer	(1)
★ 51	14-46-1360	Vertical Adjustment Stud and Nut Kit	(1)
52	44-10-0210	Vertical Adjustment Lever	(1)
53	34-60-2330	Klipring	(1)
54	44-66-0150	Vertical Backing Plate	(1)
55	31-10-0300	Vertical Guide Rail	(1)
56	06-10-3235	5/16-18 Carriage Bolt	(1)
57	44-66-6186	Bevel Plate Assembly	(1)
58	06-82-8870	Thread Form Screw T-20	(5)
59	40-50-1180	Blade Wrench Spring	(1)
60	44-72-0040	Bevel Pointer	(1)
61	06-82-5270	6-32 x 1/4" Pan Hd. Taptite T-15	(1)

FIG.	PART NO.	DESCRIPTION OF PART	NO. REQ.
62	49-96-6205	Blade Wrench	(1)
63	43-98-0085	Bevel Knob Assembly	(1)
64	45-88-0690	5/16 Handle Washer	(1)
65	25-16-0100	Shoe	(1)
66	06-82-3088	1/4-20 x 1/2" Taptite Slit. T-27	(1)
67	10-15-0315	Warning Label-Trilingual (Not Shown)	(1)
68	05-78-0305	Switch Screw (Not Shown)	(4)
69	22-84-0655	Fan Assembly	(1)

FIG. LUBRICATION

- 18 Apply 3/4 Oz. ± 1/8 Oz. Type "R" Grease, No. 49-08-0200, To Gear Bore. The Grease Should Be Directed Toward The Pinion End Of The Armature.
- 7,11 Apply A Light Coat Of Artic Grease, No. 49-08-4100, To The Machined Bore And Face Of The Lower Guard And The Mating Outer Diameter Of Hub.

FIG. NOTES:

- 52,65 When Tight, The Vertical Adjustment Lever Should Be Parallel ±20° With The Shoe At 0° Bevel.
- 16,20 Orient Flat Of Spindle Lock Shaft With Face Of Gear.
- 16,17 Orient The Needle Bearing So That The Text Faces The Gear.
- 27,31 Orient The Ball Bearing So That The Seal Faces The Armature.
- 18,19, 20,21 Press The Roll Pin Into The Lockshaft Until The Top Of The Roll Pin Is Flush With The Machined Surface Of The Upper Guard Gearcase. Roll Pin Must Not Interfer With Cork Gasket.
- 4,7 Orient The External Retaining Ring So That The Beveled Face Is Toward The Lower Guard.
- 13,14 Orient The Internal Retaining Ring So That The Beveled Face Is Opposite The Ball Bearing.
- 31,32, 37 Place The Bearing Cup Inside The Motor Housing Prior To Inserting The Ball Bearing.

MILWAUKEE ELECTRIC TOOL CORPORATION
13135 W. LISBON RD., BROOKFIELD, WI 53005
Drwg. 2