



# SERVICE PARTS LIST

**BULLETIN NO.**  
**54-40-1627**

<b>SPECIFY CATALOG NO. AND SERIAL NO. WHEN ORDERING PARTS</b>			REVISED BULLETIN 54-40-1626	DATE Sept. 2013
<b>METAL CUTTING SAW</b>			WIRING INSTRUCTION <b>58-01-0085</b>	
<b>CATALOG NO.</b>	<b>6370-20</b>	<b>SERIAL NUMBER</b>	<b>A35C</b>	

**EXAMPLE:**  
Component Parts (Small #)  
Are Included When Ordering  
The Assembly (Large #).

**SEE REVERSE SIDE  
FOR LUBRICATION  
AND SERVICE NOTES**

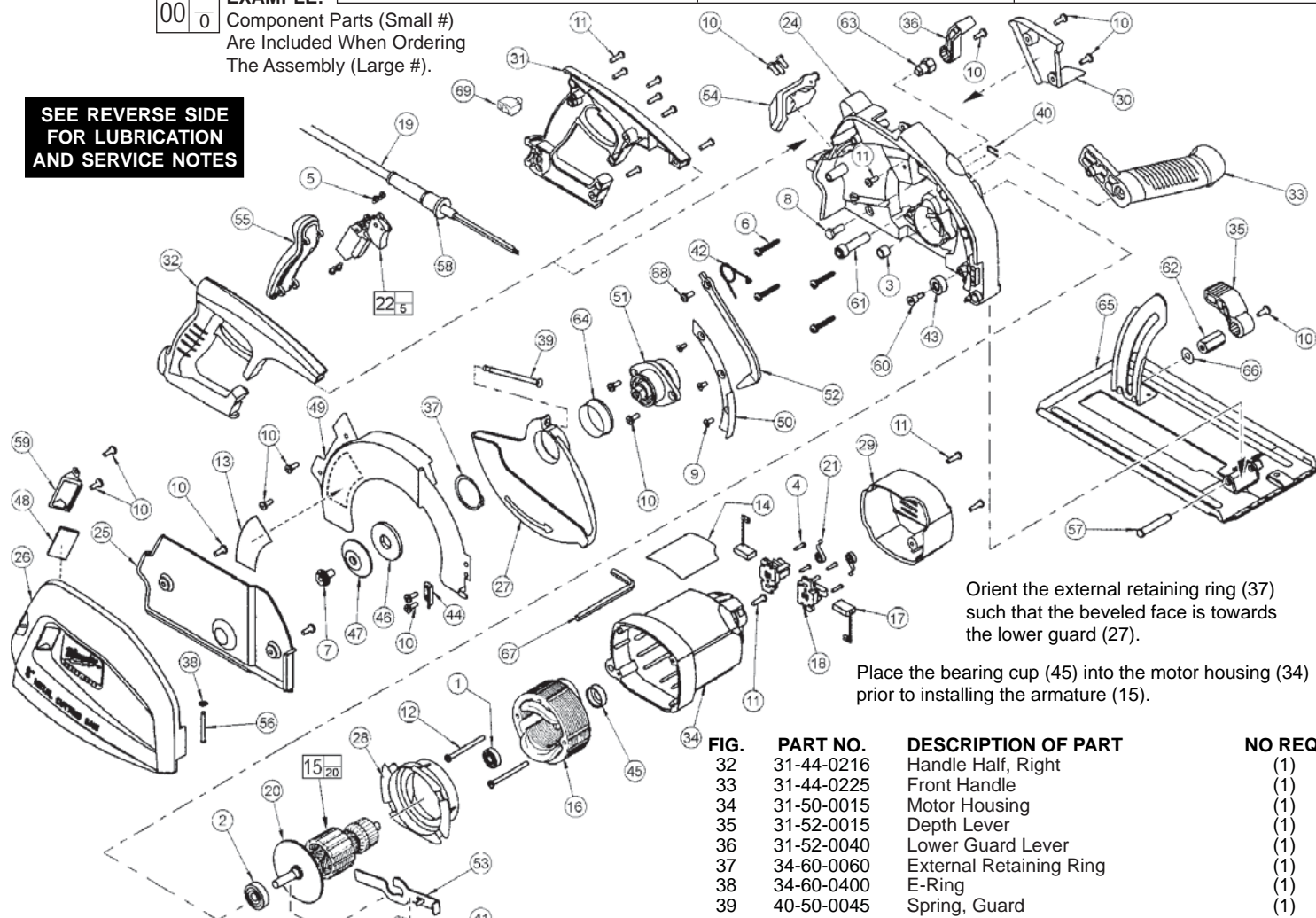

Orient the external retaining ring (37) such that the beveled face is towards the lower guard (27).

Place the bearing cup (45) into the motor housing (34) prior to installing the armature (15).

FIG.	PART NO.	DESCRIPTION OF PART	NO REQ.
1	02-04-0852	Bearing	(1)
2	02-04-1050	Bearing	(1)
3	02-50-0015	Needle Bearing	(1)
4	05-71-0035	Screws	(4)
★ 5	05-78-0130	Switch Screw	(4)
6	05-88-9925	TS5 x 30mm Phillips Hd. Screw	(4)
7	06-75-0035	5/16-18 X 9/16" Blade Screw	(1)
8	06-75-5860	1/4-20 X 3/4" Hex Hd. Screw	(1)
9	06-82-3792	8-32 x 3/8" Flat Head Taptite T-15	(3)
10	06-82-5314	10-24 X 1/2" Pan Hd. Taptite T-25	(15)
11	06-82-7270	8-16 X .625 Pan Hd. Slotted Plastite T-20	(13)
12	06-82-7453	8-16 X 2.25 Pan Hd. Slotted Plastite T20	(2)
13	10-20-0002	Warning Label, Inner Guard	(1)
14	12-20-0230	Service Nameplate Kit	(1)
15	16-62-1015	Armature	(1)
16	18-62-1015	Field Assembly	(1)
17	22-16-0060	Carbon Brush	(2)
18	22-22-0260	Brush Holder	(2)
19	22-64-0345	Cord	(1)
20	22-84-0035	Fan	(1)
21	23-52-0020	Brush Spring	(2)
★ 22	23-66-2118	Switch	(1)
23	23-94-0011	Wire Assembly (Not Shown)	(1)
24	28-14-0015	Gearcase	(1)
25	28-20-0015	Collector Cover Plate	(1)
26	28-20-0020	Collector Cover	(1)
27	28-41-0015	Lower Guard	(1)
28	31-05-0075	Fan Baffle	(1)
29	31-15-0030	Motor Cover	(1)
30	31-15-0035	Wire Cover	(1)
31	31-44-0206	Handle Half, Left	(1)

FIG.	PART NO.	DESCRIPTION OF PART	NO REQ.
32	31-44-0216	Handle Half, Right	(1)
33	31-44-0225	Front Handle	(1)
34	31-50-0015	Motor Housing	(1)
35	31-52-0015	Depth Lever	(1)
36	31-52-0040	Lower Guard Lever	(1)
37	34-60-0060	External Retaining Ring	(1)
38	34-60-0400	E-Ring	(1)
39	40-50-0045	Spring, Guard	(1)
40	40-50-0315	Wrench Clip	(1)
41	40-50-0345	Spindle Lock Spring	(1)
42	40-50-0355	Torsion Spring	(1)
43	42-38-0222	Bumper	(1)
44	42-70-0050	Cover Clip	(1)
45	42-96-0025	Bearing Cup	(1)
46	43-34-0090	Inner Flange	(1)
47	43-34-0095	Outer Flange	(1)
48	43-50-0015	Glass Window	(1)
49	43-54-0030	Inner Guard	(1)
50	43-56-0015	Chip Guide Plate	(1)
51	43-78-0025	Hub Assembly	(1)
52	44-14-0015	Lower Guard Link	(1)
53	44-20-0015	Spindle Lock	(1)
54	44-20-0050	Latch Assembly	(1)
55	44-52-0681	Grip	(1)
56	44-60-0105	Front Latch Pin	(1)
57	44-60-1180	Pivot Pin	(1)
58	44-76-0210	Cord Protector	(1)
59	44-86-0030	Window Retainer	(1)
60	45-04-0485	Bumper Screw	(1)
61	06-75-3970	Bolt	(1)
62	45-08-0015	Depth Shaft	(1)
63	45-08-0035	Shaft Lower Guard Lever	(1)
64	45-14-0020	Lower Guard Sleeve	(1)
65	45-16-0130	Shoe Assembly	(1)
66	45-88-1545	Washer	(1)
67	49-96-0345	6mm Hex Key	(1)
68	06-82-5560	10-24 X 1/2" Truss Hd. Taptite T-25	(1)
69	22-36-0160	Overload Protector	(1)

**MILWAUKEE ELECTRIC TOOL CORPORATION**  
13135 W. LISBON RD., BROOKFIELD, WI 53005  
Drwg. 2

Place spindle lock spring (41) into the spring retaining area on the gearcase (24), as shown. Press ball bearing (2) to the shoulder on the armature shaft (15). Orient the spindle lock (53) onto the armature shaft, inbetween the pressed on bearing and the front of the fan, as shown. Carefully insert the armature pinion/bearing into the gearcase. Align the spindle lock with the channel in the gearcase, making sure that the tab on the spindle lock engages the front of the spring.

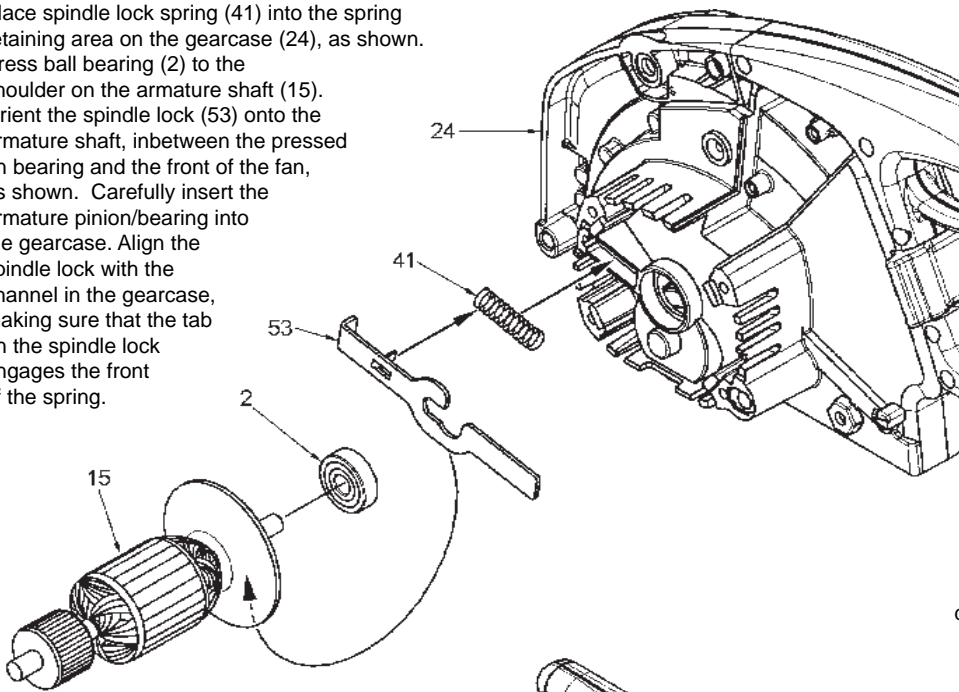

Orient the washer (66) such that the rounded edge is towards the depth rail of the shoe assembly (65).

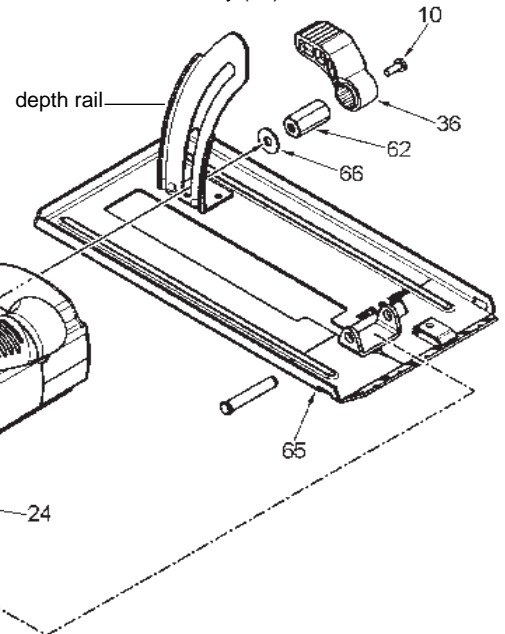

Verify that the hex head bolt (8) is fully seated in the gearcase (24) while assembling the depth shaft (62), as shown.

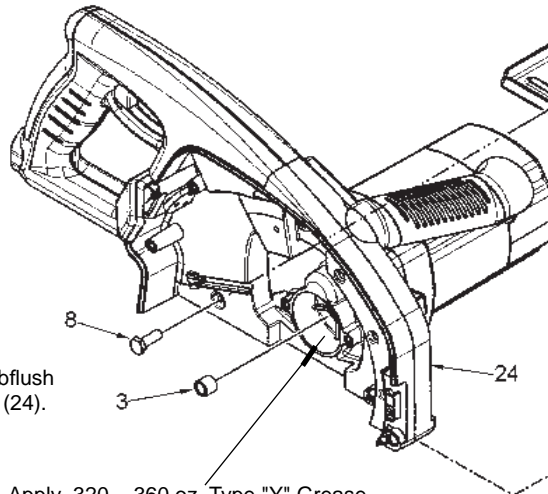

Press the bearing (3) flush to .015" subflush to the gear cavity wall in the gearcase (24).

Apply .320 - .360 oz. Type "Y" Grease, No. 49-08-5270, to gear bore of gearcase. The grease should be directed toward the pinion end of the armature.

Orient the textured gripping surface of the lower guard lever (36) so it is parallel ( $\pm 20^\circ$ ) with the back edge of the front handle (33), as shown.

Functionally check the lower guard (27), with the saw set at full depth of cut. Place the saw upside down with the shoe (65) horizontal. Retract the lower guard 100%. Release the lower guard lever (36). The guard should return in a brisk manner.

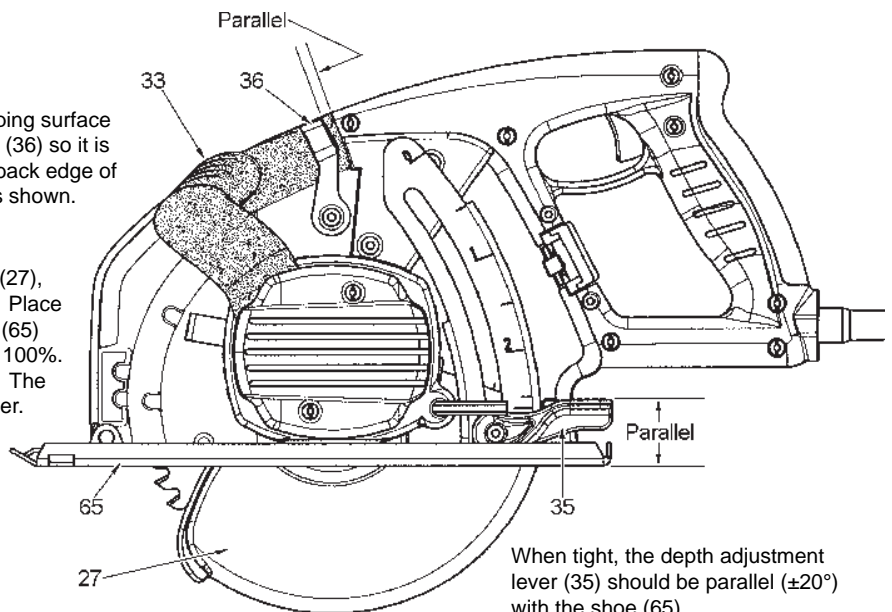

When tight, the depth adjustment lever (35) should be parallel ( $\pm 20^\circ$ ) with the shoe (65).