



SERVICE PARTS LIST

BUL. 54-40-1202

TWO SPEED BAND SAW

REVISED BUL.
54-40-1201

DATE
March '81

Catalog No.

6225

Starting
Serial No. 457-95000

WIRING INSTRUCTIONS
58-01-0721

Specify Catalog and Serial No. when ordering parts

7 AMP - High
4 AMP - Low

FIG.	PART NO.	DESCRIPTION OF PART	NO. REQ.	FIG.	PART NO.	DESCRIPTION OF PART	NO. REQ.
1	22-64-0386	Cord Set	(1)	45	12-99-0032	Nameplate	(1)
2	06-81-7800	1/4-20x3/4 Fil. Hd. Sem	(6)	46	06-81-3100	5/6-18x1 Flat Skt. Hd. Screw	(2)
3	31-44-0340	Right Handle Half	(1)	47	28-14-1380	Gear Case	(1)
4	06-81-6202	8-32x5/8 Fil. Hd. Sem	(4)	48	42-28-0210	Rear Blade Guide Block	(1)
5	31-44-0345	Left Handle Half	(1)	49	02-25-0250	Cam Follower	(6)
★6	23-66-1040	Switch	(1)	50	06-75-2110	10-24x7/8 Skt. Hd. Screw	(2)
7	06-83-2440	10-32x5/16 Hds. Skt. Screw	(1)	51	42-38-0030	Bumper	(1)
8	28-62-0010	Blade Release Lever	(1)	52	06-81-5140	10-24x1/2 Button Skt. Hd. Screw	(2)
9	23-44-0130	Brush Retaining Screw	(2)	53	32-90-0101	Worm Gear	(1)
10	22-18-0450	Carbon Brush Assembly	(2)	54	02-04-2000	Ball Bearing	(1)
11	22-22-0281	Brush Holder Assembly	(2)	55	34-40-3115	O-Ring	(1)
12	06-75-4675	3/8-16x1 Skt. Hd. Screw	(1)	56	43-76-0360	Worm Gear Shaft Housing	(1)
13	31-44-0330	Front Handle	(1)	57	02-50-6400	Needle Bearing	(1)
14	06-81-7800	1/4-20x3/4 Fil. Hd. Sem	(4)	58	06-42-2200	Woodruff Key	(1)
15	28-20-0125	Motor End Cover	(1)	59	36-66-0510	Worm Gear Shaft	(1)
16	06-81-8625	6-32x1/4 Ground Screw	(1)	60	42-60-0100	Drive Chain	(1)
17	45-88-7110	Wavy Spring Washer	(1)	61	42-12-0070	Blade Pulley Axle	(2)
★18	02-04-0911	Ball Bearing	(1)	62	31-88-0010	Sprocket	(1)
19	31-55-0061	Coil Shield	(1)	63	43-78-0220	Rear Pulley Hub	(1)
20	42-14-0150	Baffle	(1)	64	06-81-1800	1/4-20x1/2 Fil. Hd. Cap Screw	(1)
21	34-60-0827	Retaining Ring	(1)	65	02-50-4020	Needle Bearing	(4)
22	02-04-1030	Ball Bearing	(1)	66	34-60-1400	Snap Ring	(2)
23	34-60-0950	Retaining Ring	(1)	67	45-69-0010	Blade Pulley Tire	(2)
24	32-91-0111	Worm	(1)	68	28-95-0010	Blade Pulley	(2)
25	36-18-0025	Worm Drive Shaft	(1)	69	06-81-7875	1/4-20x1-1/4 Fil. Hd. Screw	(6)
26	06-42-1200	Woodruff Key	(1)	70	06-65-1155	3/16x5/8 Groove Pin	(1)
27	32-40-1680	Intermediate Gear	(1)	71	02-50-2423	Needle Bearing	(2)
28	02-04-1020	Ball Bearing	(1)	72	45-08-0145	Blade Release Shaft	(1)
29	06-83-2686	1/4-20x3/4 Set Screw	(1)	73	28-41-0500	Front Pulley Guard	(1)
30	28-28-1480	Diaphragm	(1)	74	42-28-0205	Front Blade Guide Block	(1)
★31	02-04-1040	Ball Bearing	(1)	75	02-50-1630	Needle Bearing	(1)
32	45-36-0710	Baffle Spacer	(1)	76	06-57-5000	1/4-20 Lock Nut	(2)
★33	16-62-1191	Armature (Includes Fig. No. 21)	(1)	77	45-88-7165	Pulley Hub Washer	(4)
34	06-81-6700	8-32x1-7/8 Fil Hd. Sem	(2)	78	43-78-0219	Front Pulley Hub	(1)
35	18-62-1005	Field	(1)	79	45-36-0720	Retaining Plate Spacer	(4)
36	23-16-0430	Field Insulator	(1)	80	44-66-0550	Pulley Guard Retaining Plate	(2)
37	28-50-6160	Motor Housing	(1)	81	40-50-0710	Blade Tension Spring	(2)
38	06-81-5692	10-24x1/2 Pan Hd. Screw	(1)	82	42-18-0190	Blade Tension Bar	(2)
39	43-54-0250	Blade Guard	(1)	83	06-75-0255	1/4-20x4 Hex. Hd. Screw	(2)
40	45-04-0450	Shoulder Screw	(1)	84	06-75-0150	1/4-20x1 Hex. Hd. Screw	(2)
41	48-39-0360	Band Saw Blade	(1)	85	06-81-2950	1/4-20X1-1/4 Flat Hd. Skt. Screw	(4)
42	06-81-1230	1/4-20 x1-1/8 Fil. Hd. Screw	(4)	86	06-65-1206	3/16x3/4 Groove Pin	(1)
43	06-75-2405	10-32x5/8 Skt. Hd. Screw	(2)	87	44-52-0120	Blade Backing Pad	(1)
44	06-85-0200	Nameplate Screw	(2)	88	45-36-1000	Spacer	(1)
				89	12-98-7082	Caution Plate (Not Shown)	(1)

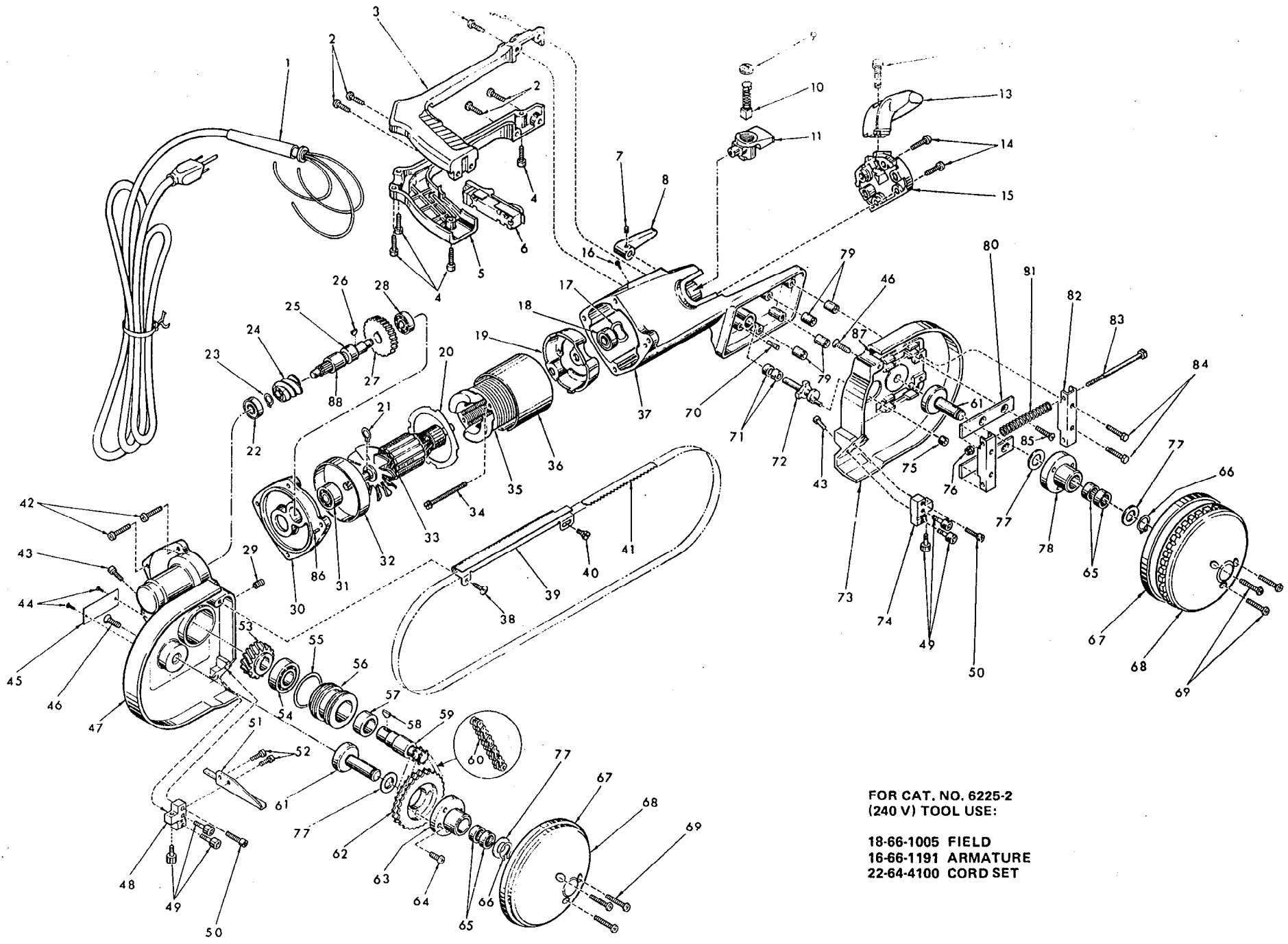

FOR CAT. NO. 6225-2
(240 V) TOOL USE:

- 18-66-1005 FIELD
- 16-66-1191 ARMATURE
- 22-64-4100 CORD SET