



SERVICE PARTS LIST

BULLETIN NO.
54-38-3702

SPECIFY CATALOG NO. AND SERIAL NO. WHEN ORDERING PARTS		REVISED BULLETIN	DATE
4-1/2" SUPER MAG GRINDER		54-38-3701	Mar. 2003
CATALOG NO. 6153-20	STARTING SERIAL NUMBER 906C	WIRING INSTRUCTION	

EXAMPLE:

00	0
----	---

Component Parts (Small #)
Are Included When Ordering
The Assembly (Large #).

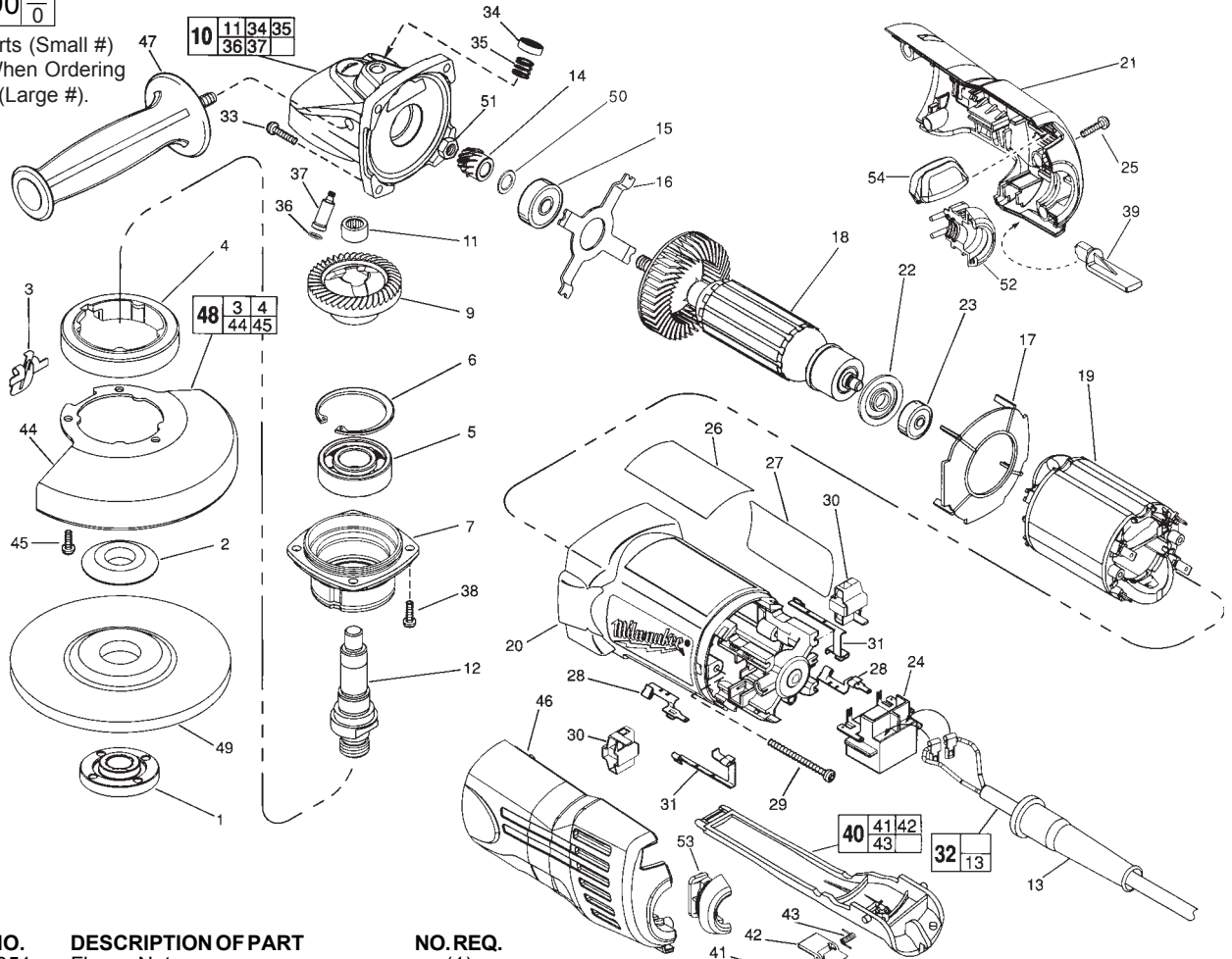

FIG.	PART NO.	DESCRIPTION OF PART	NO. REQ.
1	49-05-0051	Flange Nut	(1)
2	49-05-0041	Flange	(1)
3	44-20-0325	Lock Lever	(1)
4	45-36-1551	Spacer	(1)
5	02-04-1745	Ball Bearing	(1)
6	34-80-2960	Retaining Ring - Internal	(1)
7	28-52-0222	Spindle Hub	(1)
9	32-05-1310	P.M. Gear	(1)
10	25-14-2351	Gear Case Assembly	(1)
11	02-50-2423	Needle Bearing	(1)
12	38-50-5202	Spindle	(1)
13	44-76-0210	Cord Protector	(1)
14	32-60-1310	Pinion Gear	(1)
15	02-04-0852	Ball Bearing	(1)
16	44-66-5345	Bearing Retainer Plate	(1)
17	42-14-0400	Baffle	(1)
★18	16-10-2006	Armature	(1)
19	18-10-2005	Field	(1)
20	31-50-1100	Motor Housing	(1)
21	31-44-0660	Right Cover	(1)
★22	23-16-0101	Commutator Insulator	(1)
23	02-04-2080	Ball Bearing	(1)
24	23-66-2401	Switch	(1)
25	06-82-7271	6-19 x 7/8" Pan Hd. Plastite T-15	(4)
26	12-20-6201	Service Nameplate Kit	(1)
27	10-98-7091	Warning Label	(1)
28	23-74-1206	Brush Terminal	(2)
29	06-82-7421	6-19 x 3-1/4" Pan Hd. Slit. Plast. T-15	(2)
30	22-20-0920	Brush Holder Assy. (Incl. Carbon Brush)	(2)
31	23-74-1201	Switch Terminal	(2)
32	22-64-0845	Cord Set Assembly	(1)
33	06-82-7326	8-16 x 1" Pan Hd. Slit. Plast. T-20	(4)
34	31-12-0205	Cap	(1)
35	40-50-8650	Compression Spring	(1)
36	34-40-4300	O-Ring	(1)
37	44-60-0845	Lock Pin	(1)
38	06-82-5316	8-32 x 1/2" Pan Hd. Slit. Tapt. T-20	(4)
39	31-53-0080	Plug	(1)

FIG.	PART NO.	DESCRIPTION OF PART	NO. REQ.
40	31-92-0320	Paddle Assembly	(1)
41	06-65-1915	Pin	(1)
42	42-42-0390	Lock-Off Button	(1)
43	40-50-8750	Torsion Spring	(1)
44	28-41-1020	Hood	(1)
45	06-82-7251	8-16 x 3/8" Pan Hd. Slit. Plast. T-20	(3)
46	31-44-0665	Left Cover	(1)
47	49-15-0310	Side Handle	(1)
48	49-12-0365	Guard Assembly	(1)
49	-----	4-1/2" Disc - Select From Catalog	(1)
50	45-14-0280	Pinion Shim	(1)
51	06-55-3850	10-32 Hex Nut	(1)
52	31-17-0260	Cord Clamp Half-Right	(1)
53	31-17-0265	Cord Clamp Half-Left	(1)
54	31-53-0150	Plug	(1)
	49-96-7205	Spanner Wrench	(1)

FIG. LUBRICATION:
9,14 Type "Y" Grease, No. 49-08-5270, Must Be Applied To All Gear Teeth.
10 9-12 Grams Type "Y" Grease, No. 49-08-5270.

FIG. NOTES:
7 Position The Spindle Hub With The Side That Has The Word "Back" Orientated Toward The Rear Of The Tool.
11 Press .09" Below Casting Surface With Lettering Readable After Assembly.
32 Tuck All Cord Leads Away From Vent Openings. Cord Leads
51 Are Interchangeable On Switch Connections. Torque To 25-35 In./Lbs.