

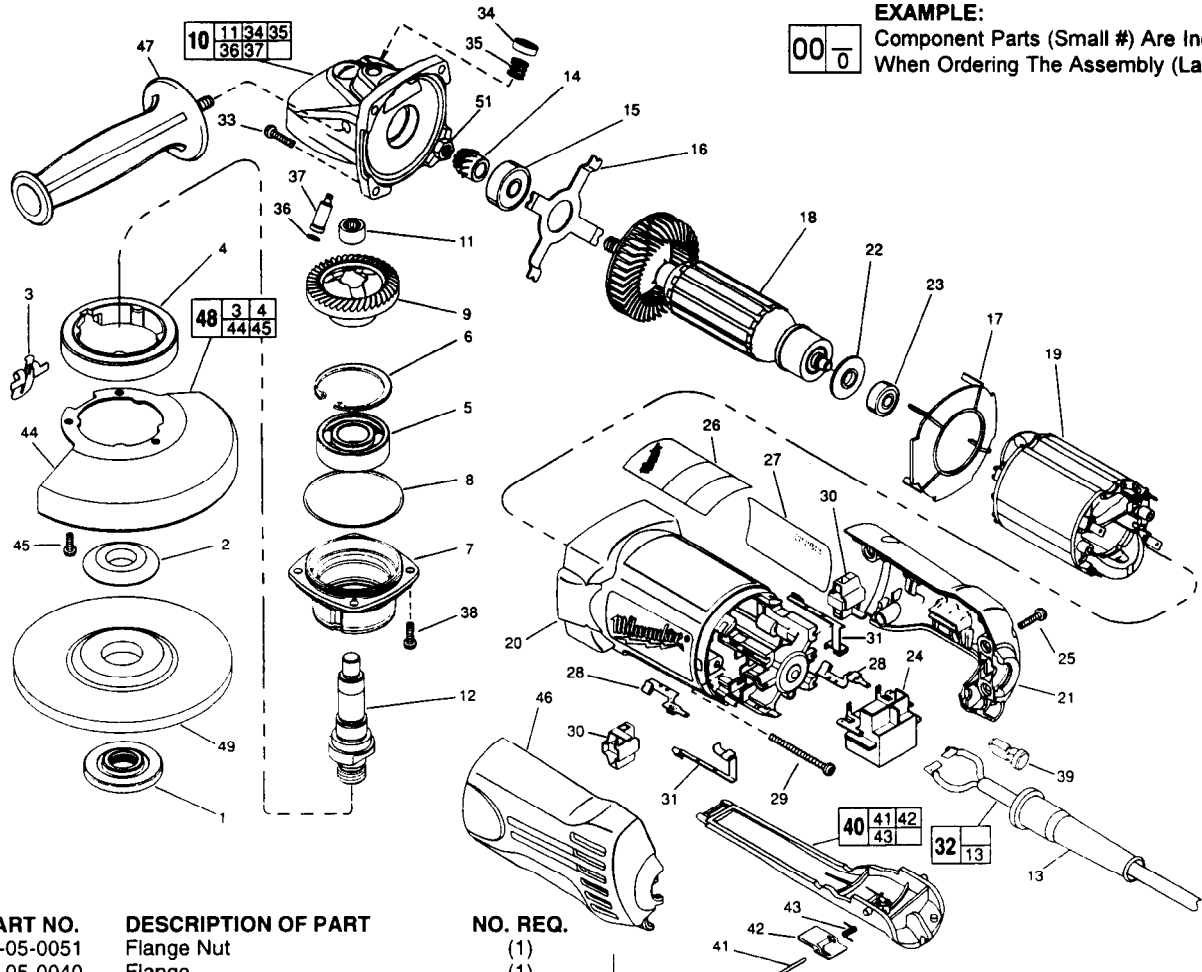

SERVICE PARTS LIST

BULLETIN NO.
54-38-0476

SPECIFY CATALOG NO. AND SERIAL NO. WHEN ORDERING PARTS		REVISED BULLETIN 54-38-0475	DATE Aug. '98
4-1/2" ANGLE GRINDER			
CATALOG NO. 6151	STARTING SERIAL NUMBER	868C	
WIRING INSTRUCTION			



EXAMPLE:
Component Parts (Small #) Are Included
When Ordering The Assembly (Large #).



FIG.	PART NO.	DESCRIPTION OF PART	NO. REQ.
1	49-05-0051	Flange Nut	(1)
2	49-05-0040	Flange	(1)
3	44-20-0325	Lock Lever	(1)
★ 4	45-36-1551	Spacer	(1)
5	02-04-1746	Ball Bearing	(1)
6	34-80-2960	Retaining Ring - Internal	(1)
★ 7	28-52-0221	Spindle Hub	(1)
8	34-40-4400	O-Ring	(1)
9	32-05-1310	P.M. Gear	(1)
10	25-14-2350	Gear Case Assembly	(1)
11	02-50-2423	Needle Bearing	(1)
12	38-50-5202	Spindle	(1)
13	44-76-0210	Cord Protector	(1)
14	32-60-1310	Pinion Gear	(1)
15	02-04-2075	Ball Bearing	(1)
16	44-66-5345	Bearing Retainer Plate	(1)
17	42-14-0400	Baffle	(1)
18	16-07-0126	Armature	(1)
19	18-07-0125	Field	(1)
20	31-50-1100	Motor Housing	(1)
21	31-15-0450	Right Cover	(1)
★ 22	23-16-0916	Commutator Insulator	(1)
23	02-04-2080	Ball Bearing	(1)
★ 24	23-66-2401	Switch	(1)
25	06-82-7271	6-19 x 7/8" Pan Hd. Plastite T-15	(4)
26	12-20-1100	Service Nameplate Kit	(1)
27	10-98-7090	Warning Label	(1)
★ 28	23-74-1206	Brush Terminal	(2)
29	06-82-7420	6-19 x 2-3/4" Pan Hd. Slit. Plast. T-15	(2)
30	22-20-0555	Brush Holder Assy. (Incl. Carbon Brush)	(2)
★ 31	23-74-1201	Switch Terminal	(2)
32	22-64-0840	Cord Set Assembly	(1)
33	06-82-7326	8-16 x 1" Pan Hd. Slit. Plast. T-20	(4)
34	31-12-0205	Cap	(1)

FIG.	PART NO.	DESCRIPTION OF PART	NO. REQ.
35	40-50-8650	Compression Spring	(1)
36	34-40-4300	O-Ring	(1)
37	44-60-0845	Lock Pin	(1)
38	06-82-5316	8-32 x 1/2" Pan Hd. Slit. Tapt. T-20	(4)
39	31-53-0112	Plug	(1)
40	31-92-0320	Paddle Assembly	(1)
41	06-65-1915	Pin	(1)
42	42-42-0390	Lock-Off Button	(1)
43	40-50-8750	Torsion Spring	(1)
44	42-92-0950	Hood	(1)
45	06-82-7251	8-16 x 3/8" Pan Hd. Slit. Plast. T-20	(3)
46	31-15-0455	Left Cover	(1)
47	49-15-0310	Side Handle	(1)
48	28-41-0975	Guard Assembly	(1)
49	-----	4-1/2" Disc - Select From Catalog	(1)
★ 51	06-55-3850	10-32 Hex Nut	(1)
	49-96-7201	Spanner Wrench	(1)

FIG. LUBRICATION:
9,14 Type "O" Grease, No. 49-08-4200, Must Be Applied
To All Gear Teeth.
10 18-21 Grams Type "O" Grease, No. 49-08-4200.

FIG. NOTES:
5 Seal To Face External Environment.
11 Press .09" Below Casting Surface.
32 Tuck All Cord Leads Away From Vent Openings.