

SPECIFY CATALOG NO. AND SERIAL NO. WHEN ORDERING PARTS		REVISED BULLETIN	DATE
4.5" ANGLE GRINDER with SLIDE SWITCH			Dec. 2009
CATALOG NO. 6148-33	STARTING SERIAL NUMBER	B73A	
		WIRING INSTRUCTION See Reverse Side	

FIG.	PART NO.	DESCRIPTION OF PART	NO. REQ.
1	05-55-0620	M5 Hex Nut	(1)
2	05-88-1100	M3 x 10 Pan Hd. Screw	(2)
3	05-88-1210	M4 x 14 Pan Hd. T-20 Screw	(4)
4	05-88-1255	M4 x 22 Pan Hd. T-20 Screw	(8)
5	05-88-1280	M4 x 10 Pan Hd. T-20 Screw	(2)
6	05-88-1290	M4 x 76 T-20 Screw	(2)
7	05-90-0225	M4 Lock Washer	(6)
9	10-15-1230	Warning Label	(1)

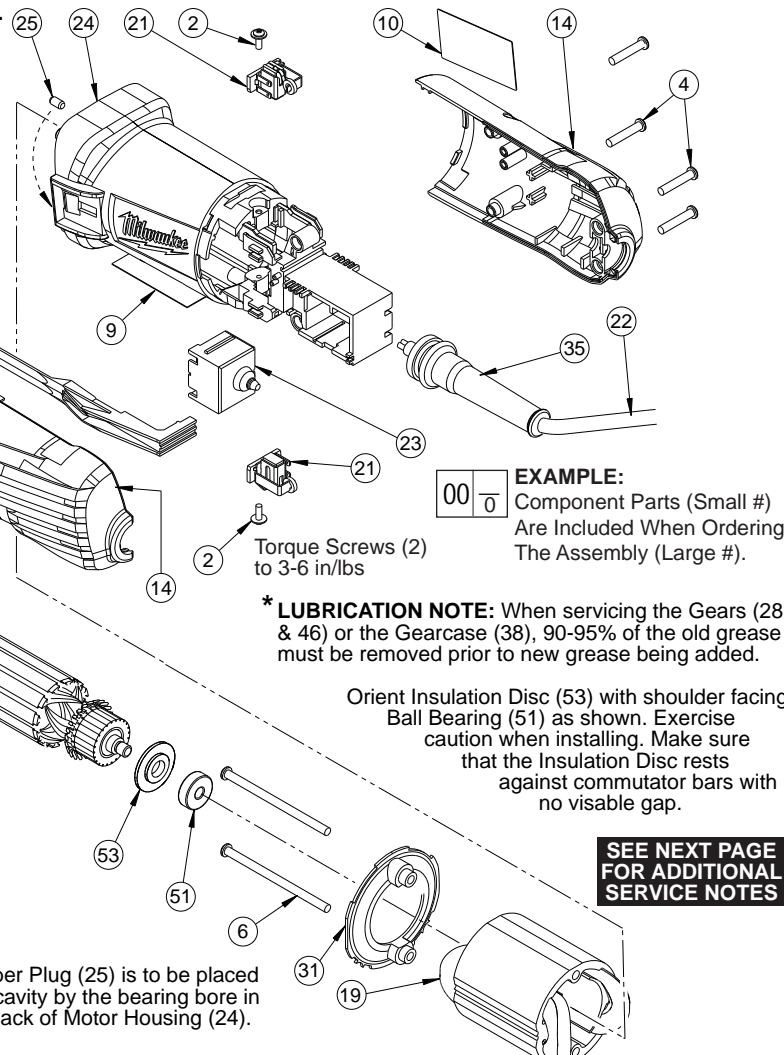
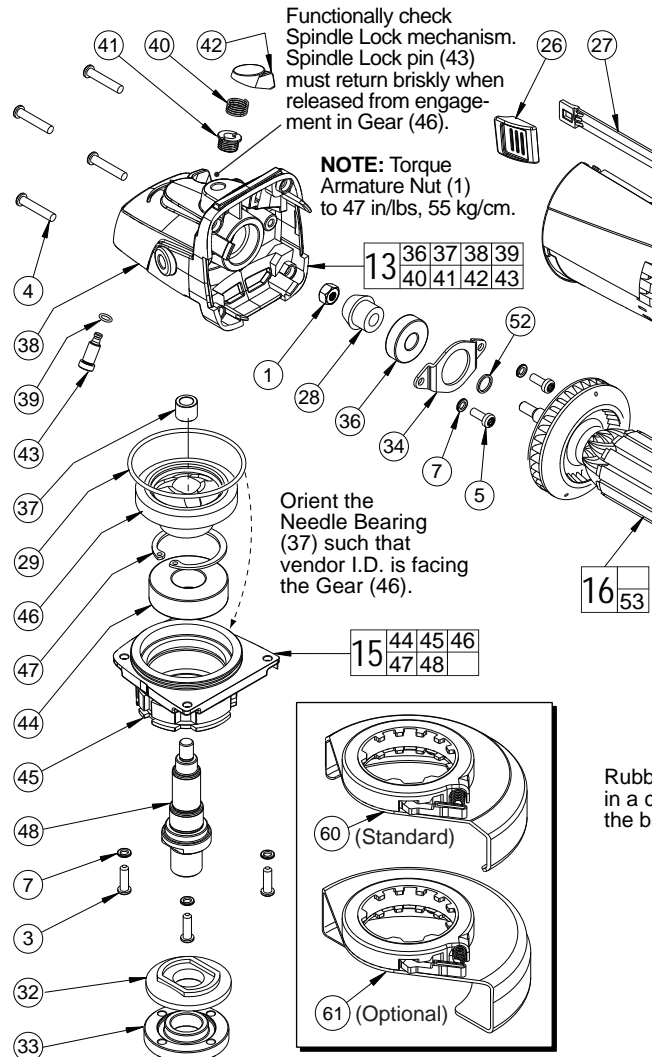

EXAMPLE:
Component Parts (Small #)
Are Included When Ordering
The Assembly (Large #).

*** LUBRICATION NOTE:** When servicing the Gears (28 & 46) or the Gearcase (38), 90-95% of the old grease must be removed prior to new grease being added.

Orient Insulation Disc (53) with shoulder facing Ball Bearing (51) as shown. Exercise caution when installing. Make sure that the Insulation Disc rests against commutator bars with no visible gap.

SEE NEXT PAGE FOR ADDITIONAL SERVICE NOTES

Rubber Plug (25) is to be placed in a cavity by the bearing bore in the back of Motor Housing (24).

FIG.	PART NO.	DESCRIPTION OF PART	NO. REQ.
10	12-20-6116	Service Nameplate	(1)
13	14-29-0310	Gearcase Assembly	(1)
14	14-34-0720	Rear Handle Assembly	(1)
15	14-73-0410	Spindle/Hub Assembly	(1)
16	16-10-7020	Service Armature Assembly	(1)
19	18-07-2300	Service Field	(1)
21	22-22-1560	Carbon Brush Assembly	(2)
22	22-64-2020	Cord	(1)
23	23-66-2665	Switch	(1)
24	31-50-3370	Motor Housing	(1)
25	31-53-0240	Rubber Slug	(1)
26	31-92-0430	Slide Switch Button	(1)
27	31-92-0470	Switch Pole	(1)
28	32-60-1310	Bevel Pinion	(1)
29	34-40-0180	O-Ring	(1)
31	42-14-0025	Fan Baffle	(1)
32	43-34-0036	Inner Disk Flange	(1)
33	44-40-0035	Outer Flange Nut	(1)
34	44-66-0450	Bearing Retainer	(1)
35	44-76-0210	Strain Relief	(1)
36	02-04-0620	Ball Bearing	(1)

FIG.	PART NO.	DESCRIPTION OF PART	NO. REQ.
37	02-50-0025	Needle Bearing	(1)
38	-----	Gearcase	(1)
39	34-40-0450	O-Ring	(1)
40	40-50-1330	Compression Spring	(1)
41	42-42-0580	Spindle Lock Tube	(1)
42	42-42-0590	Spindle Lock Button	(1)
43	42-60-1660	Spindle Lock Pin	(1)
44	02-04-1150	Ball Bearing	(1)
45	28-53-0410	Lower Gearcase Hub	(1)
46	32-05-1310	Bevel Gear	(1)
47	34-80-2275	Retaining Ring	(1)
48	38-50-1280	Spindle	(1)
51	02-04-2110	Ball Bearing	(1)
52	45-88-0406	Washer	(1)
53	43-86-0010	Insulation Disc	(1)
60	43-54-1070	4.5" T27 Guard Assembly (Standard)	(1)
61	43-54-1090	4.5" T1 Guard Assembly (Optional)	(1)
	42-62-0100	Side Handle (Not Shown)	(1)
	49-96-7215	Spanner Wrench (Not Shown)	(1)

FIG. LUBRICATION (*See lubrication note above):
28,46 Type "Y" Grease, No. 49-08-5270, Must Be Applied To All Gear Teeth.
29,38 Lightly coat with grease O-Ring and bearing bore in Gearcase.
38 .3 -.4 Ounces (9-12 Grams) Type "Y" Grease, No. 49-08-5270.

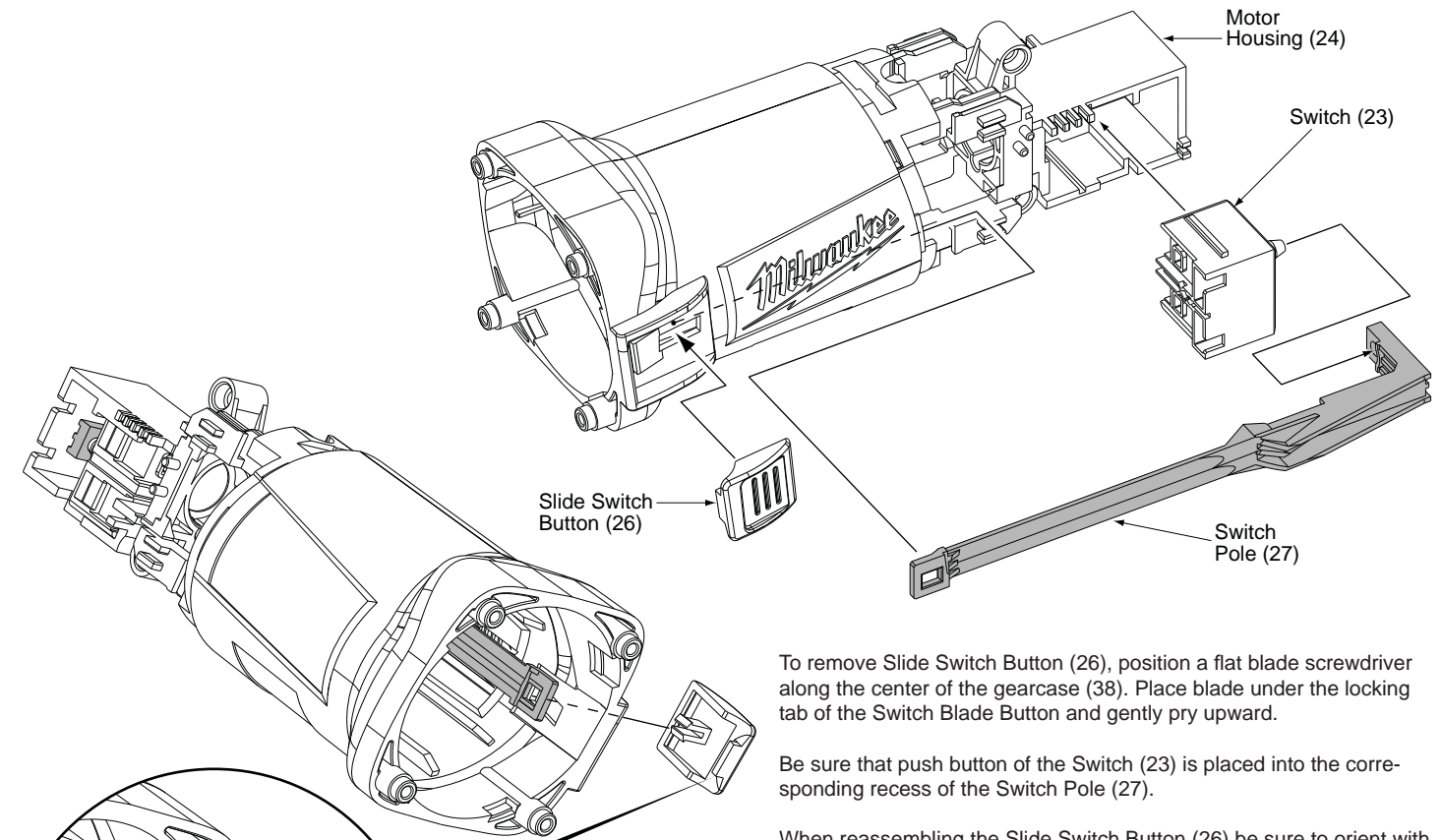

To remove Slide Switch Button (26), position a flat blade screwdriver along the center of the gearcase (38). Place blade under the locking tab of the Switch Blade Button and gently pry upward.

Be sure that push button of the Switch (23) is placed into the corresponding recess of the Switch Pole (27).

When reassembling the Slide Switch Button (26) be sure to orient with the locking tab as shown, towards the gearcase (38).

When servicing the Motor Housing (24) or the Switch Pole (27) it is recommended to snap the Slide Switch Button (26) into the Switch Pole, as shown prior to installing the Field (19).

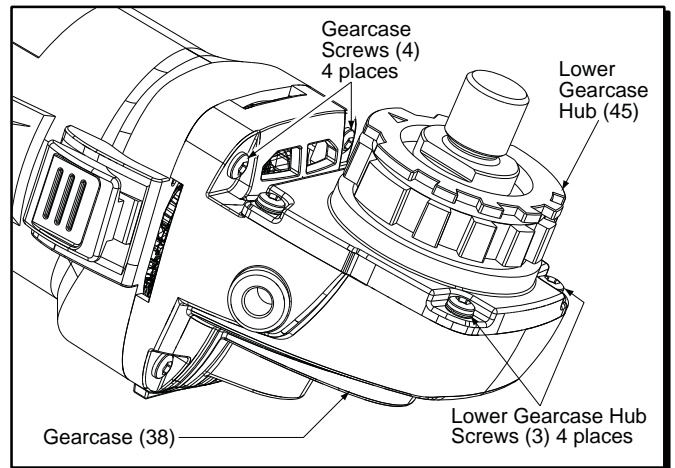
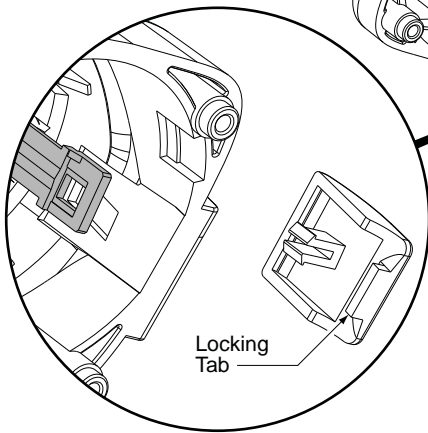

When servicing the Gearcase (38), first remove the four Screws (3) and Lower Gearcase Hub (45) to prevent damage to the bottom two Screws (4) that secure the Gearcase.

AS AN AID TO REASSEMBLY, TAKE NOTICE OF WIRE ROUTING AND POSITION IN WIRE GUIDES AND TRAPS WHILE DISMANTLING TOOL.

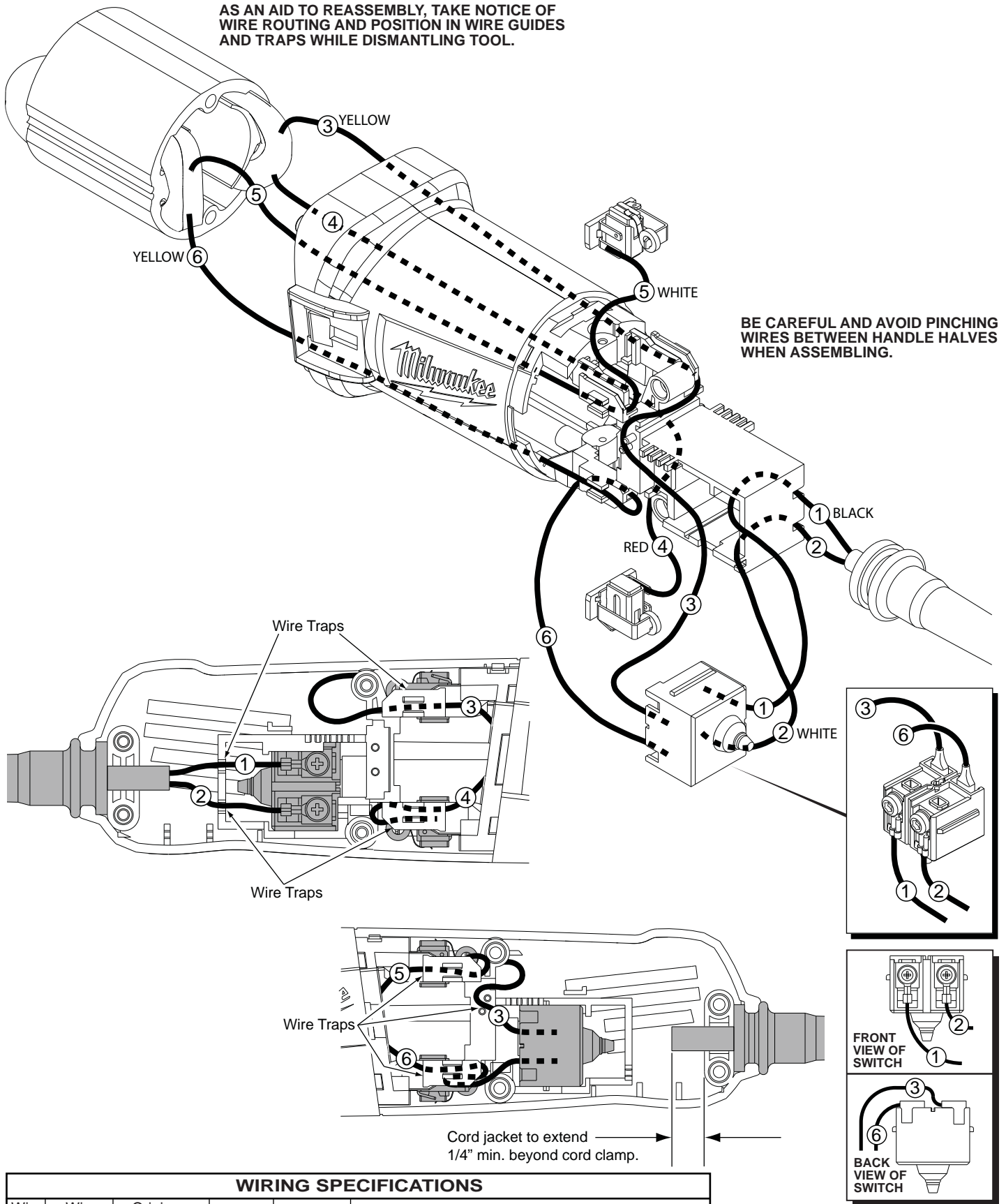

Wire Traps

Wire Traps

Wire Traps

Cord jacket to extend 1/4" min. beyond cord clamp.

BE CAREFUL AND AVOID PINCHING WIRES BETWEEN HANDLE HALVES WHEN ASSEMBLING.

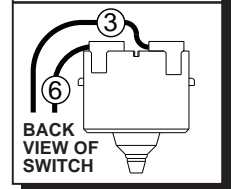
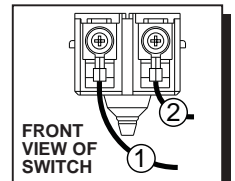
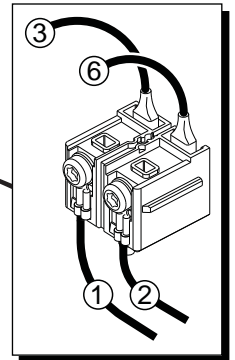

WIRING SPECIFICATIONS

Wire No.	Wire Color	Origin or Part No.	Gauge	Length	Terminals, Connectors and End Wire Preparation
1	Black	22-64-2020	--	--	Component of cord set.
2	Black	22-64-2020	--	--	Component of cord set.
3	Yellow	18-07-2300	--	--	Component of field.
4	Red	18-07-2300	--	--	Component of field.
5	White	18-07-2300	--	--	Component of field.
6	Yellow	18-07-2300	--	--	Component of field.

BULK LEAD WIRE - BULLETIN 58-01-0003

NOTE:

All leads must be held to $\pm 1/16"$.
All lead lengths are before stripping.

TERMINAL DESCRIPTION

Code	Part No.	Qty.