



# SERVICE PARTS LIST

**BULLETIN NO.**  
**54-38-0259**

SPECIFY CATALOG NO. AND SERIAL NO. WHEN ORDERING PARTS		REVISED BULLETIN	DATE
<b>5" D.I. SANDER-GRINDER</b>		54-38-0258	Apr. '97
CATALOG NO. <b>6141</b>	STARTING SERIAL NO. <b>763C</b>	WIRING INSTRUCTION <b>58-01-0309</b>	

**EXAMPLE:**  

00	0
----	---

 Component Parts (Small #) Are Included  
 When Ordering The Assembly (Large #).

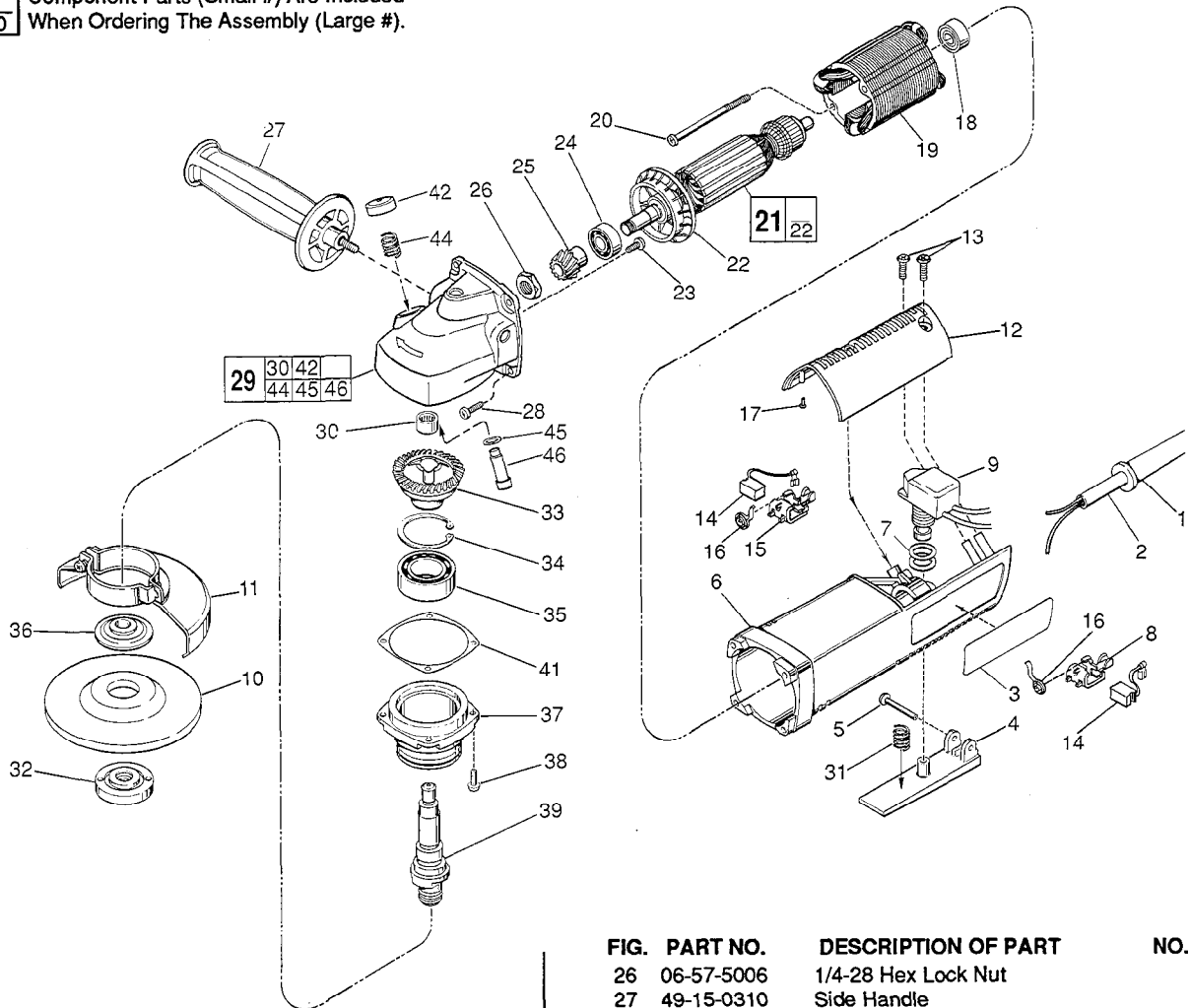

FIG.	PART NO.	DESCRIPTION OF PART	NO. REQ.
	1	44-76-0130 Cord Protector	(1)
	2	22-64-0215 Cord Set	(1)
	3	12-20-0510 Service Nameplate Kit	(1)
	4	31-92-0112 Trigger	(1)
	5	06-72-0815 .146 Dia. x 1-3/8" Rivet	(1)
	6	31-50-0425 Motor Housing	(1)
★	7	34-40-4015 O-Ring	(2)
	8	22-20-0691 Left Brush Holder	(1)
★	9	23-66-2171 Switch	(1)
	10	5" Disc-Select from Catalog	(1)
	11	49-12-0330 Wheel Guard Assembly	(1)
	12	31-15-0143 Cover	(1)
	13	06-82-7270 8-16x5/8" Pan Hd. Slit. Plast. T-20	(3)
	14	22-18-0710 Carbon Brush	(2)
	15	22-20-0692 Right Brush Holder	(1)
	16	23-52-0240 Brush Spring	(2)
	17	42-38-0181 Rubber Bumper	(2)
	18	02-04-0848 Ball Bearing	(1)
	19	18-07-0055 120 Volt Field	(1)
	20	06-82-7375 8-16x2-1/2" Pan Hd. Plast. T-20	(2)
	21	16-07-0060 120 Volt Armature	(1)
	22	22-84-0680 Fan	(1)
	23	06-82-2292 8-32x3/8" Pan Hd. Slit. Taptite T-20	(2)
	24	02-04-1020 Ball Bearing	(1)
	25	32-60-1305 Pinion	(1)

FIG.	PART NO.	DESCRIPTION OF PART	NO. REQ.
	26	06-57-5006 1/4-28 Hex Lock Nut	(1)
	27	49-15-0310 Side Handle	(1)
	28	06-82-7270 8-16x5/8" Pan Hd. Slit. Plast. T-20	(4)
	29	14-30-0301 Gear Case Assembly	(1)
	30	02-50-2423 Needle Bearing	(1)
	31	40-50-1300 Coil Spring	(1)
	32	49-05-0051 Flange Nut	(1)
	33	32-05-2240 Spiral Bevel Gear	(1)
	34	34-80-2960 Retaining Ring-Internal	(1)
	35	02-04-1746 Ball Bearing	(1)
	36	49-05-0070 Flange	(1)
	37	28-53-0220 Spindle Hub	(1)
	38	06-82-5316 8-32x1/2" Pan Hd. Slit. Taptite T-20	(4)
	39	38-50-5202 Spindle	(1)
	41	45-14-0160 Shim	(0-3)
★	42	31-12-0205 Cap	(1)
★	44	40-50-8650 Coil Spring	(1)
	45	34-40-4300 O-Ring	(1)
★	46	44-60-0845 Lock Pin	(1)
		49-96-7201 Spanner Wrench	(1)

**FIG. LUBRICATION**  
 29 1/4 Oz. "O" Grease, No. 49-08-4200.

**FIG. NOTES:**  
 26 Torque To 60 In./Lbs.

**MILWAUKEE ELECTRIC TOOL CORPORATION**  
 13135 W. LISBON RD., BROOKFIELD, WI 53005