



SERVICE PARTS LIST

BULLETIN NO.
55-38-3557

SPECIFY CATALOG NO. AND SERIAL NO. WHEN ORDERING PARTS		REVISED BULLETIN	DATE
4-1/2" D.I. SANDER-GRINDER		55-38-3556	May '96
CATALOG NO. 6140-2	STARTING SERIAL NO. 762F	WIRING INSTRUCTION 58-01-0309	

EXAMPLE:

00	0
----	---

 Component Parts (Small #) Are Included
 When Ordering The Assembly (Large #).

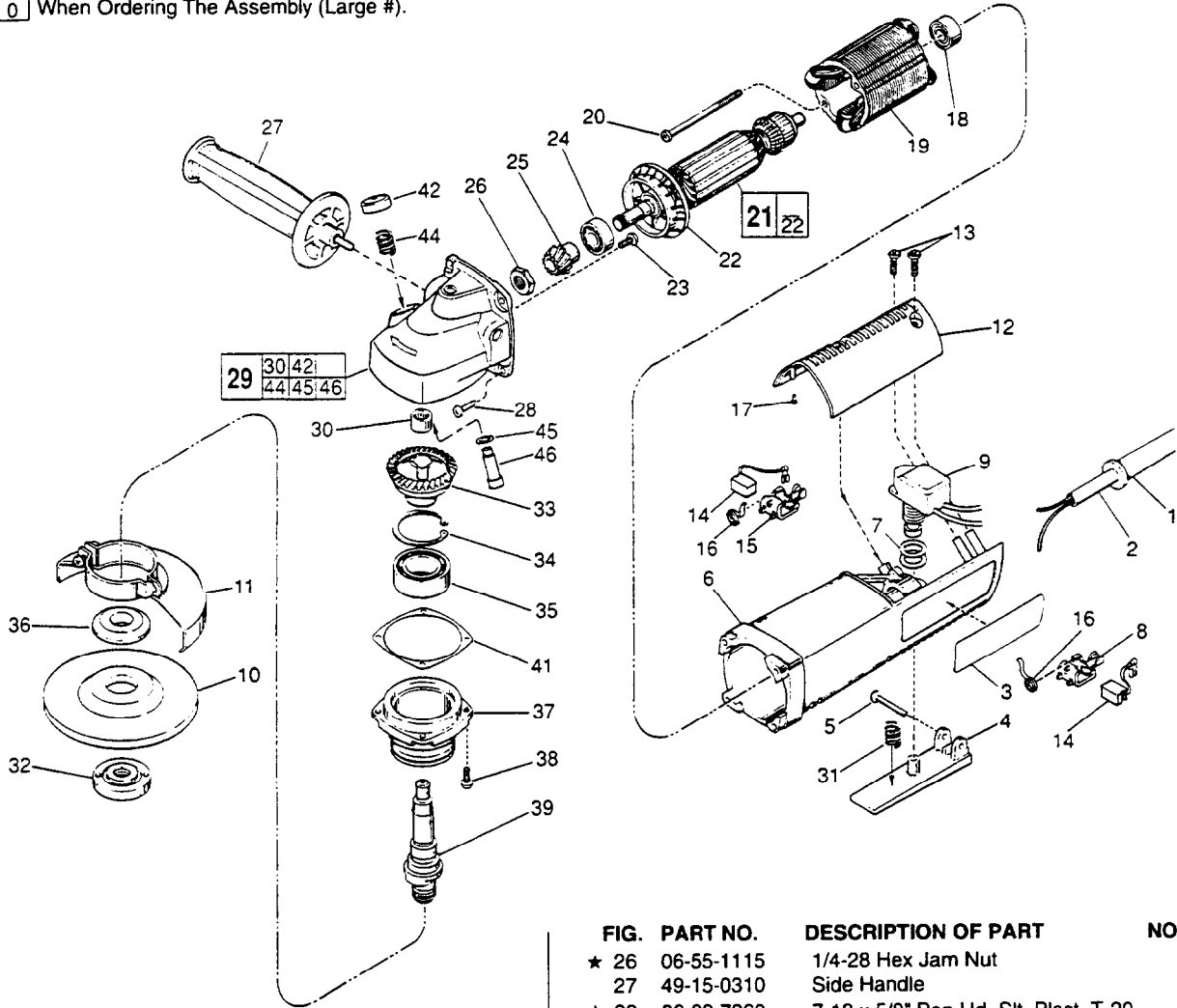

FIG.	PART NO.	DESCRIPTION OF PART	NO. REQ.
1	44-76-0130	Cord Protector	(1)
2	22-64-4535	Cord Set	(1)
3	12-20-0500	Service Nameplate Kit	(1)
4	31-92-0112	Trigger	(1)
5	06-72-0815	.146 Dia. x 1-3/8" Rivet	(1)
★ 6	31-50-0426	Motor Housing	(1)
7	34-40-4015	O-Ring	(2)
8	22-20-0691	Left Brush Holder	(1)
9	23-66-2171	Switch	(1)
10	-----	4-1/2" Disc-Select from Catalog	(1)
11	49-12-0320	Wheel Guard Assembly	(1)
12	31-15-0143	Cover	(1)
13	06-82-7270	8-16 x 5/8" Pan Hd. Slit. Plast. T-20	(3)
14	22-18-0750	Carbon Brush	(2)
15	22-20-0692	Right Brush Holder	(1)
16	23-52-0240	Brush Spring	(2)
17	42-38-0181	Rubber Bumper	(2)
18	02-04-0848	Ball Bearing	(1)
19	18-06-0055	240 Volt Field	(1)
20	06-82-7375	8-16 x 2-1/2" Pan Hd. Plast. T-20	(2)
21	16-06-0060	240 Volt Armature	(1)
22	22-84-0680	Fan	(1)
23	06-82-2292	8-32 x 3/8" Pan Hd. Slit. Taptite T-20	(2)
24	02-04-1020	Ball Bearing	(1)
25	32-60-1305	Pinion	(1)

FIG.	PART NO.	DESCRIPTION OF PART	NO. REQ.
★ 26	06-55-1115	1/4-28 Hex Jam Nut	(1)
27	49-15-0310	Side Handle	(1)
★ 28	06-82-7260	7-18 x 5/8" Pan Hd. Slit. Plast. T-20	(4)
29	14-30-0301	Gear Case Assembly	(1)
30	02-50-2423	Needle Bearing	(1)
31	40-50-1300	Coil Spring	(1)
32	49-05-0051	Flange Nut	(1)
33	32-05-2240	Spiral Bevel Gear	(1)
34	34-80-2960	Retaining Ring-Internal	(1)
35	02-04-1746	Ball Bearing	(1)
36	49-05-0040	Flange	(1)
37	28-53-0220	Spindle Hub	(1)
38	06-82-5316	8-32 x 1/2" Pan Hd. Slit. Taptite T-20	(4)
39	38-50-5202	Spindle	(1)
41	45-14-0160	Shim	(0-3)
42	31-12-0205	Cap	(1)
44	40-50-8650	Coil Spring	(1)
45	34-40-4300	O-Ring	(1)
46	44-60-0845	Lock Pin	(1)
	49-96-7201	Spanner Wrench	(1)

FIG. LUBRICATION

29 1/4 Oz. "O" Grease, No. 49-08-4200.

FIG. NOTES:

26 Torque To 60 In./Lbs.

MILWAUKEE ELECTRIC TOOL CORPORATION
 13135 W. LISBON RD., BROOKFIELD, WI 53005