



SERVICE PARTS LIST

BULLETIN NO.
54-38-3554

SPECIFY CATALOG NO. AND SERIAL NO. WHEN ORDERING PARTS		REVISED BULLETIN	DATE
4-1/2" D.I. SANDER-GRINDER		54-38-3553	Feb.'94
CATALOG NO. 6140	STARTING SERIAL NO. 762A	WIRING INSTRUCTION 58-01-0309	

EXAMPLE:

Component Parts (Small #) Are Included
When Ordering The Assembly (Large #).

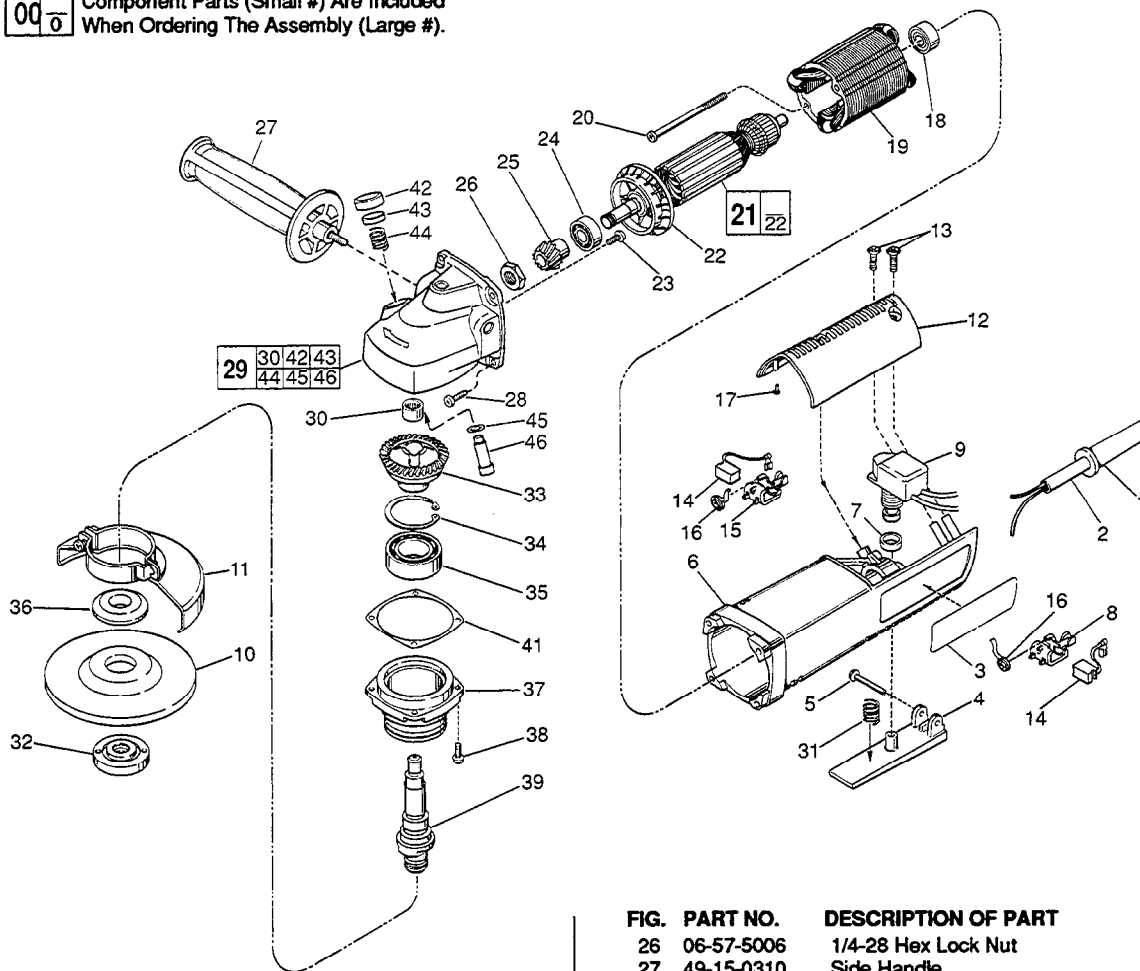

FIG. PART NO.	DESCRIPTION OF PART	NO. REQ.
1	44-76-0130 Cord Protector	(1)
2	22-64-0215 Cord Set	(1)
★ 3	12-20-0490 Service Nameplate Kit	(1)
4	31-92-0112 Trigger	(1)
5	06-72-0815 .146 Dia. x 1-3/8" Rivet	(1)
6	31-50-0425 Motor Housing	(1)
7	44-90-4245 Rubber Ring	(1)
8	22-20-0691 Left Brush Holder	(1)
9	23-66-2170 Switch	(1)
10	4-1/2" Disc-Select from Catalog	(1)
11	49-12-0320 Wheel Guard Assembly	(1)
★ 12	31-15-0143 Cover	(1)
13	06-82-7270 8-16x5/8" Pan Hd. Slit. Plast. T-20	(3)
14	22-18-0710 Carbon Brush	(2)
15	22-20-0692 Right Brush Holder	(1)
16	23-52-0240 Brush Spring	(2)
17	42-38-0181 Rubber Bumper	(2)
18	02-04-0848 Ball Bearing	(1)
19	18-07-0055 120 Volt Field	(1)
20	06-82-7375 8-16x2-1/2" Pan Hd. Plast. T-20	(2)
21	16-07-0060 120 Volt Armature	(1)
22	22-84-0680 Fan	(1)
23	06-82-2292 8-32x3/8" Pan Hd. Slit. Taptite T-20	(2)
24	02-04-1020 Ball Bearing	(1)
25	32-60-1300 Pinion	(1)

FIG. PART NO.	DESCRIPTION OF PART	NO. REQ.
26	06-57-5006 1/4-28 Hex Lock Nut	(1)
27	49-15-0310 Side Handle	(1)
28	06-82-7270 8-16x5/8" Pan Hd. Slit. Plast. T-20	(4)
29	14-30-0301 Gear Case Assembly	(1)
30	02-50-2423 Needle Bearing	(1)
31	40-50-1300 Coil Spring	(1)
32	49-05-0051 Flange Nut	(1)
33	32-05-2230 Spiral Bevel Gear	(1)
34	34-80-2960 Retaining Ring-Internal	(1)
35	02-04-1746 Ball Bearing	(1)
36	49-05-0040 Flange	(1)
37	28-53-0220 Spindle Hub	(1)
38	06-82-5316 8-32x1/2" Pan Hd. Slit. Taptite T-20	(4)
39	38-50-5202 Spindle	(1)
41	45-14-0160 Shim	(0-3)
42	31-12-0265 Cap	(1)
43	42-42-0075 Lock Button	(1)
44	40-50-1300 Coil Spring	(1)
45	34-40-4300 O-Ring	(1)
46	44-60-1370 Lock Pin	(1)
	49-96-7201 Spanner Wrench	(1)

FIG. LUBRICATION

29 1/4 Oz. "O" Grease, No. 49-08-4200.

FIG. NOTES:

26 Torque To 60 In./Lbs.

MILWAUKEE ELECTRIC TOOL CORPORATION
13135 W. LISBON RD., BROOKFIELD, WI 53005