



SERVICE PARTS LIST

BULLETIN NO.
54-38-3552

SPECIFY CATALOG NO. AND SERIAL NO. WHEN ORDERING PARTS		REVISED BULLETIN	DATE
4-1/2" D.I. SANDER-GRINDER		54-38-3551	Mar.'93
CATALOG NO. 6140	STARTING SERIAL NO. 762-197163	WIRING INSTRUCTION 58-01-0309	

EXAMPLE:

00 **0** Component Parts (Small #) Are Included
When Ordering The Assembly (Large #).

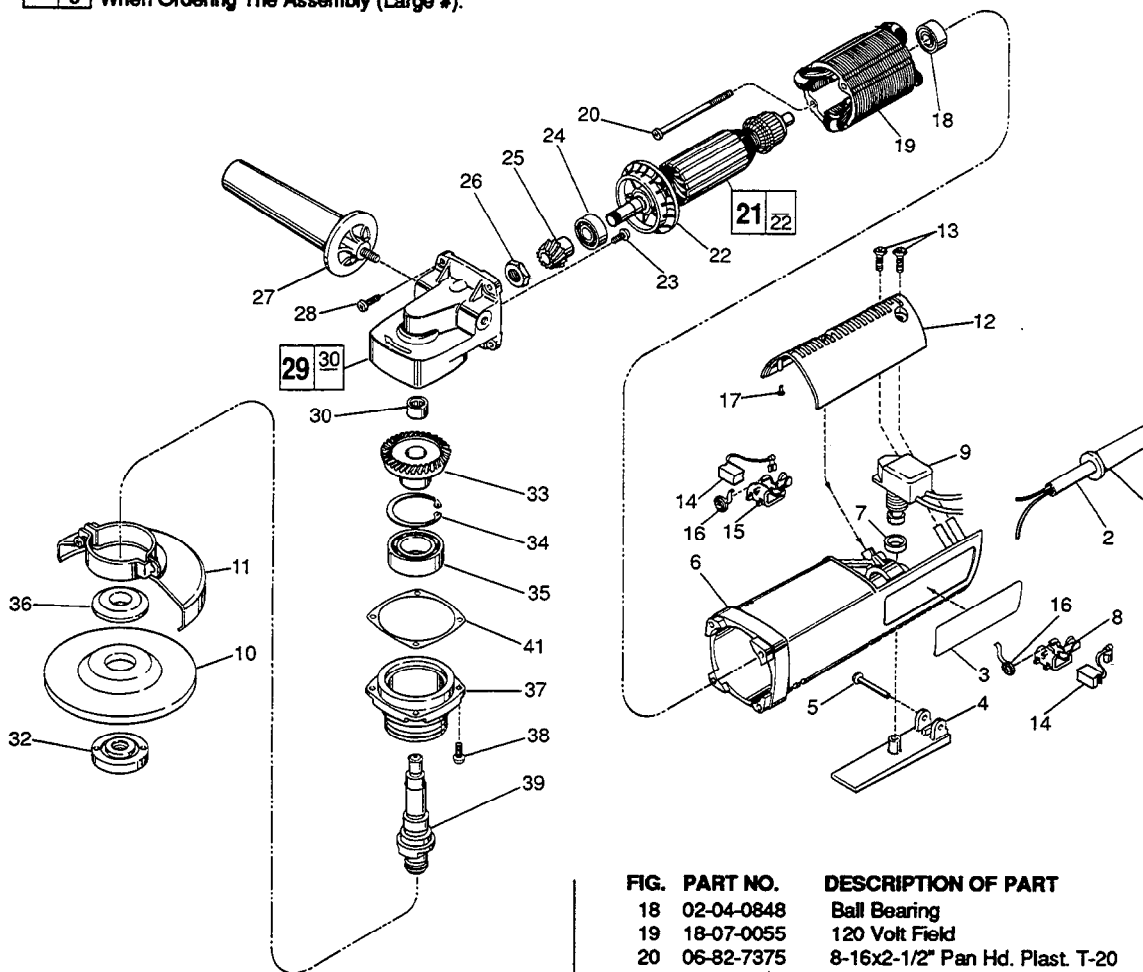

FIG.	PART NO.	DESCRIPTION OF PART	NO. REQ.
1	44-76-0130	Cord Protector	(1)
2	22-64-0215	Cord Set	(1)
3	12-65-4128	Service Nameplate	(1)
4	31-92-0110	Trigger	(1)
5	06-72-0815	.146 Dia. x 1-3/8" Rivet	(1)
6	31-50-0425	Motor Housing	(1)
7	44-90-4245	Rubber Ring	(1)
8	22-20-0691	Left Brush Holder	(1)
★ 9	23-66-2170	Switch	(1)
10		4-1/2" Disc-Select from Catalog	(1)
11	49-12-0320	Wheel Guard Assembly	(1)
12	31-15-0142	Cover	(1)
13	06-82-7270	8-16x5/8" Pan Hd. Stt. Plast. T-20	(3)
14	22-18-0710	Carbon Brush	(2)
15	22-20-0692	Right Brush Holder	(1)
16	23-52-0240	Brush Spring	(2)
17	42-38-0181	Rubber Bumper	(2)

FIG.	PART NO.	DESCRIPTION OF PART	NO. REQ.
18	02-04-0848	Ball Bearing	(1)
19	18-07-0055	120 Volt Field	(1)
20	06-82-7375	8-16x2-1/2" Pan Hd. Plast. T-20	(2)
21	16-07-0060	120 Volt Armature	(1)
22	22-84-0680	Fan	(1)
23	06-82-2292	8-32x3/8" Pan Hd. Stt. Taptite T-20	(2)
24	02-04-1020	Ball Bearing	(1)
25	32-60-1300	Pinion	(1)
26	06-57-5006	1/4-28 Hex Lock Nut	(1)
27	49-15-0251	Side Handle	(1)
28	06-82-7270	8-16x5/8" Pan Hd. Stt. Plast. T-20	(4)
29	14-30-0300	Gear Case Assembly	(1)
30	02-50-2423	Needle Bearing	(1)
31	28-14-1421	Gear Case	(1)
32	49-05-0051	Flange Nut	(1)
33	32-05-1300	Spiral Bevel Gear	(1)
34	34-80-2960	Retaining Ring-Internal	(1)
35	02-04-1746	Ball Bearing	(1)
36	49-05-0040	Flange	(1)
37	28-53-0220	Spindle Hub	(1)
38	06-82-5316	8-32x1/2" Pan Hd. Stt. Taptite T-20	(4)
39	38-50-5202	Spindle	(1)
41	45-14-0160	Shim	(0-3)
	49-96-4078	3/4" Wrench	(1)
	49-96-7201	Spanner Wrench	(1)

FIG. LUBRICATION

31 1/4 Oz. "O" Grease No. 49-08-4200.

MILWAUKEE ELECTRIC TOOL CORPORATION
13135 W. LISBON RD., BROOKFIELD, WI 53005