



SERVICE PARTS LIST

BULLETIN NO.
54-38-2150

SPECIFY CATALOG NO. AND SERIAL NO. WHEN ORDERING PARTS		REVISED BULLETIN	DATE
4.5" COMPACT RAT-TAIL ANGLE GRINDER with lock-on			Sept. 2012
CAT. NO.	6121-30	STARTING SERIAL NUMBER	C96A
		WIRING INSTRUCTION See Reverse Side	

FIG.	PART NO.	DESCRIPTION OF PART	NO. REQ.
1	05-88-1650	M4 x 25mm Pan Hd. ST Screw T-20	(7)
2	42-62-0120	Side Handle Assembly	(1)
3	14-30-1155	Gearcase Assembly	(1)
3a	-----	Spindle Lock Button	(1)
3b	-----	Spindle Lock Spring	(1)
3c	-----	Gearcase	(1)
3d	-----	O-Ring	(1)
3e	-----	Spindle Lock Pin	(1)
3f	-----	Needle Bearing	(1)
3g	02-04-0620	Ball Bearing	(1)
4	34-40-0560	O-Ring	(1)
5	14-73-0415	Spindle Hub Assembly	(1)
5a	-----	Spiral Bevel Gear	(1)

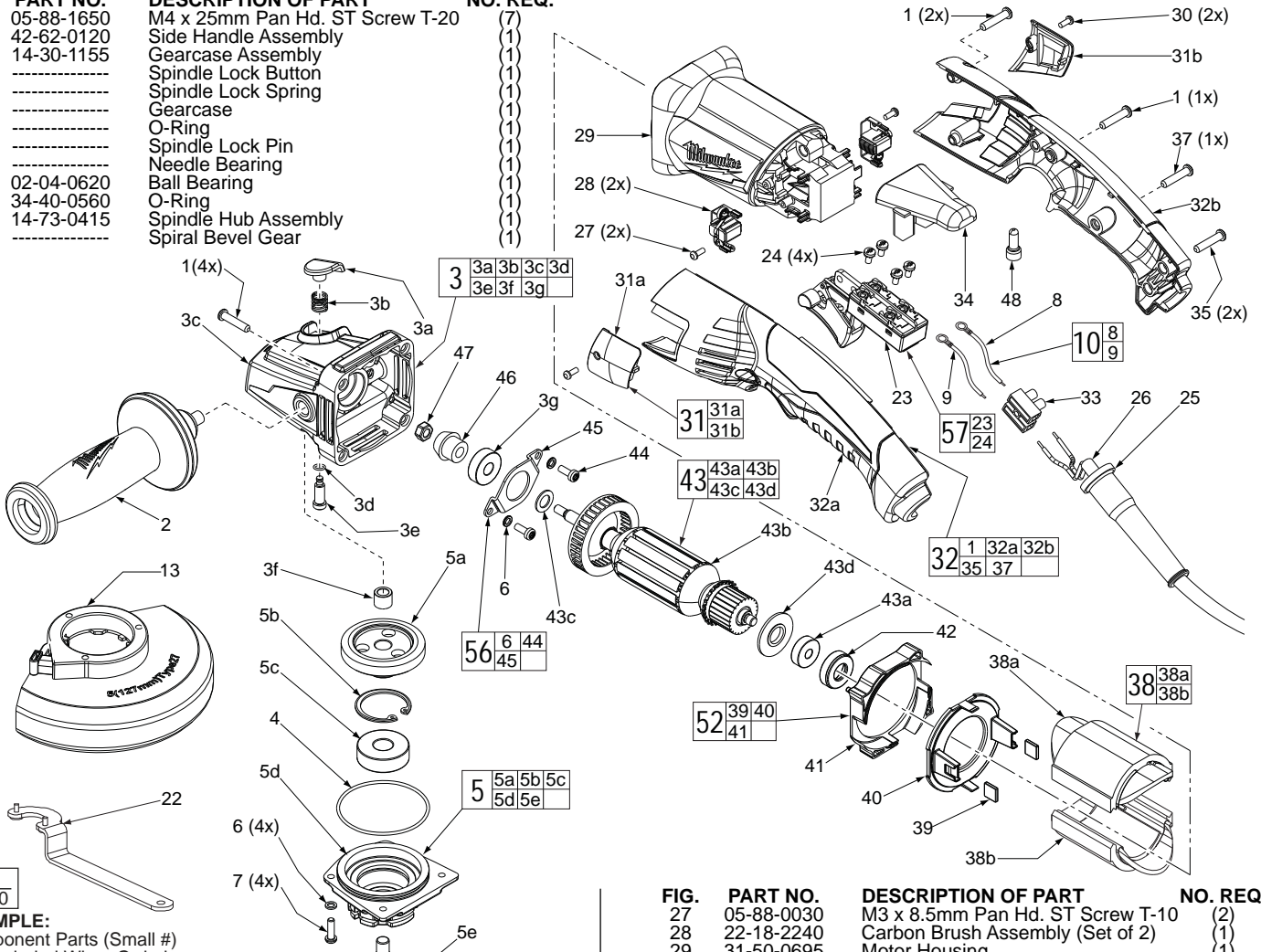

EXAMPLE:
Component Parts (Small #)
Are Included When Ordering
The Assembly (Large #).

***LUBRICATION NOTE:**
When servicing the Gears (5a & 46)
or the Gearcase (3c), 90-95% of the
old grease must be removed prior
to new grease being added.

FIG. LUBRICATION*
5a,46 Type "Y" Grease, No. 49-08-5270,
Must Be Applied To All Gear Teeth.

5b	-----	Retaining Ring	(1)
5c	-----	Ball Bearing	(1)
5d	-----	Spindle Hub	(1)
5e	-----	5/8" Spindle	(1)
6	05-90-0225	Spring Washer	(4)
7	05-88-1210	M4 x 14mm T-20	(6)
8	-----	Leadwire - Black	(1)
9	-----	Leadwire - White	(1)
10	23-94-0345	Leadwire Assy. Kit	(1)
13	14-32-0210	4.5" Type 27 Guard Assembly (Shown)	(1)
13	43-54-0920	4.5" Type 1 Guard Assy. (Not Shown)	(1)
15	-----	O-Ring	(1)
16	-----	Wavey Spring	(1)
17	-----	Flange with Ramps	(1)
18	-----	Retaining Ring	(1)
19	43-34-0935	Inner Disc Flange	(1)
21	44-40-0035	Outer Flange Nut	(1)
22	49-96-7205	Spanner Wrench	(1)
23	23-66-2695	Trigger Switch	(1)
24	05-78-0305	M3.5 x 7mm Pan Hd. Phil. Switch Scr.	(4)
25	44-76-0095	Cord Protector	(1)
26	22-64-3425	Power Cord	(1)

FIG.	PART NO.	DESCRIPTION OF PART	NO. REQ.
27	05-88-0030	M3 x 8.5mm Pan Hd. ST Screw T-10	(2)
28	22-18-2240	Carbon Brush Assembly (Set of 2)	(1)
29	31-50-0695	Motor Housing	(1)
30	06-82-2395	M2.6 x 10mm Pan Hd. ST Screw T-9	(2)
31	31-15-1005	Brush Cover Assembly (Set of 2)	(1)
31a	-----	Brush Cover - Left	(1)
31b	-----	Brush Cover - Right	(1)
32	14-34-6115	Rear Handle Set (For lock-on switch)	(1)
32a	-----	Handle Halve - Left	(1)
32b	-----	Handle Halve - Right	(1)
33	22-56-0475	Terminal Connector Block	(1)
34	22-09-1825	PCB Assembly	(1)
35	05-88-1255	M4 x 22mm Pan Hd. ST T-20	(2)
37	06-82-1020	M4 x 14mm Pan Hd. ST T-20	(1)
38	18-07-0285	Field Assembly	(1)
38a	-----	Field Halve	(1)
38b	-----	Field Halve	(1)
39	42-28-0085	Rubber Block	(2)
40	-----	Baffle Foot	(1)
41	-----	Baffle	(1)
42	42-96-0016	Rubber Bearing Cap	(1)
43	16-10-0850	Armature Assembly	(1)
43a	02-04-2110	Ball Bearing	(1)
43b	-----	Armature	(1)
43c	45-88-0406	Washer	(1)
43d	31-86-0090	Plastic Disc	(2)
44	05-88-1280	M4 x 10mm Pan Hd. Mach. Screw T-20	(2)
45	44-86-0155	Bearing Retainer	(1)
46	32-60-0300	Pinion	(1)
47	05-55-0620	M5 Hex Nut	(1)
48	22-56-0150	Close End Connector	(1)
50	14-46-6105	Flange with Ramps Assembly	(1)
52	42-14-0520	Baffle Assembly	(1)
56	44-86-0145	Bearing Retaining Plate Assembly	(1)
57	14-78-0550	Trigger Switch Assembly	(1)

NOTE:
PCBA wire #10 can be routed to the lower right switch position or connect with white wire #4 in terminal block T1 as shown .

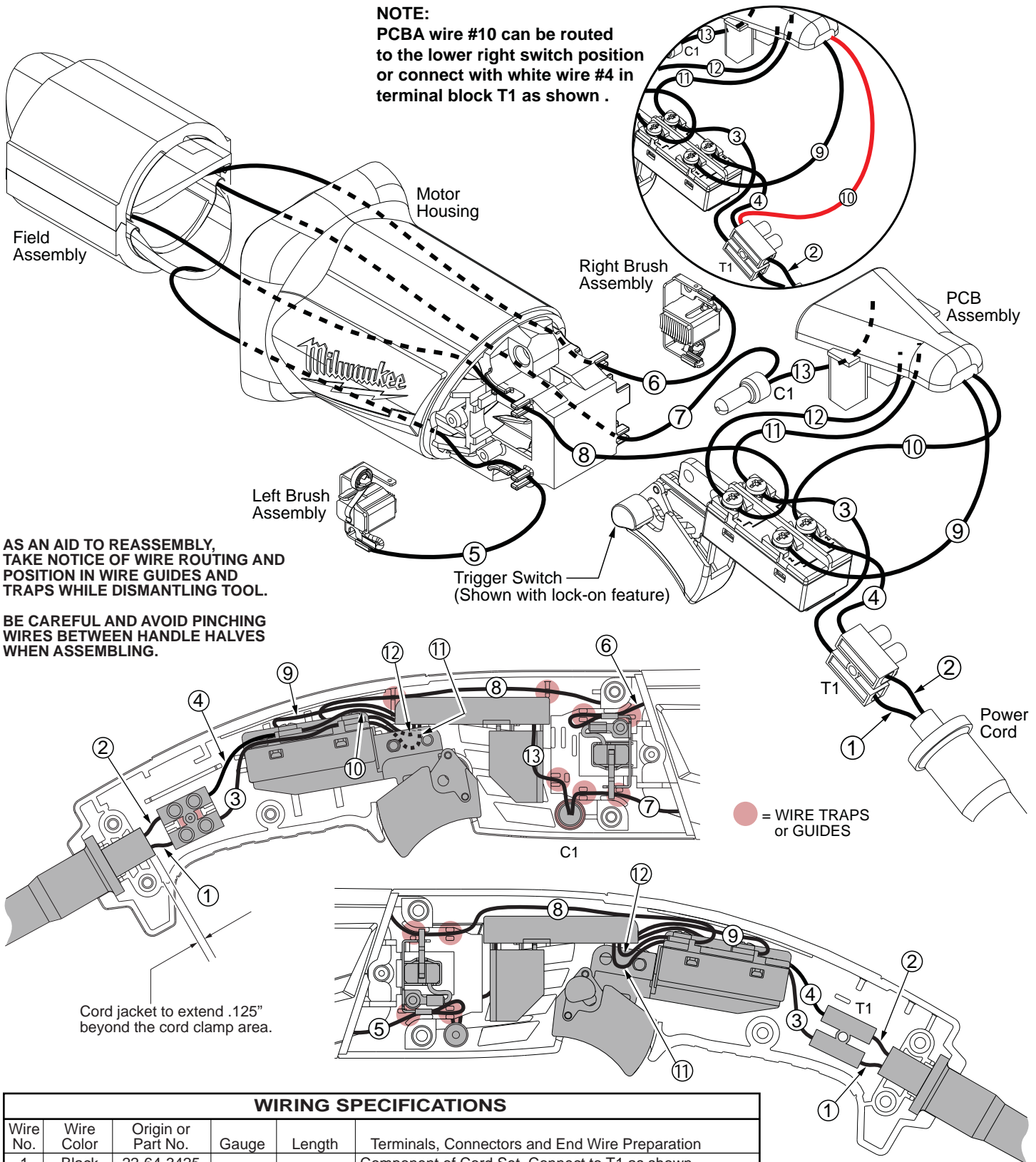

AS AN AID TO REASSEMBLY, TAKE NOTICE OF WIRE ROUTING AND POSITION IN WIRE GUIDES AND TRAPS WHILE DISMANTLING TOOL.

BE CAREFUL AND AVOID PINCHING WIRES BETWEEN HANDLE HALVES WHEN ASSEMBLING.

Cord jacket to extend .125" beyond the cord clamp area.

WIRING SPECIFICATIONS

Wire No.	Wire Color	Origin or Part No.	Gauge	Length	Terminals, Connectors and End Wire Preparation
1	Black	22-64-3425	--	--	Component of Cord Set. Connect to T1 as shown.
2	White	22-64-3425	--	--	Component of Cord Set. Connect to T1 as shown.
3	Black	23-94-0345	--	--	Comp. of Leadwire Assembly Kit. Connect to Switch and T1 as shown.
4	White	23-94-0345	--	--	Comp. of Leadwire Assembly Kit. Connect to Switch and T1 as shown.
5	Black	18-07-0285	--	--	Comp. of Field. Connect to Left Brush Assy. as shown.
6	Black	18-07-0285	--	--	Comp. of Field. Connect to Right Brush Assy. as shown.
7	Black	18-07-0285	--	--	Comp. of Field. Connect to Wire #13 with C1 as shown.
8	Black	18-07-0285	--	--	Component of Field. Connect to Switch as shown.
9	White	22-09-1825	--	--	Comp. of PCB Assembly. Connect to Switch as shown.
10	White	22-09-1825	--	--	Comp. of PCB Assy. Connect to Switch or T1 as shown.
11	Black	22-09-1825	--	--	Comp. of PCB Assembly. Connect to Switch as shown.
12	Blue	22-09-1825	--	--	Comp. of PCB Assembly. Connect to Switch as shown.
13	Red	22-09-1825	--	--	Comp. of PCB Assembly. Connect to Wire #7 with C1.

BULK LEAD WIRE - BULLETIN 58-01-0003

NOTE:
All leads must be held to ± 1/16".
All lead lengths are before stripping.

TERMINAL DESCRIPTION		
Code	Part No.	Qty.
T1	22-56-0475	1
CONNECTOR DESCRIPTION		
C1	22-56-0150	1