



# SERVICE PARTS LIST

**BULLETIN NO.**  
54-38-2100

SPECIFY CATALOG NO. AND SERIAL NO. WHEN ORDERING PARTS		REVISED BULLETIN	DATE
5" HP ANGLE GRINDER with PADDLE SWITCH with lock-on			Aug. 2013
CAT. NO.	6117-30	STARTING SERIAL NUMBER	C91A
		WIRING INSTRUCTION <b>See Reverse Side</b>	

FIG.	PART NO.	DESCRIPTION OF PART	NO. REQ.
1	05-88-1650	M4 x 25mm Pan Hd. ST Screw T-20	(4)
2	42-62-0125	Side Handle Assembly	(1)
3	14-30-1155	Gearcase Assembly	(1)
3a	-----	Spindle Lock Button	(1)
3b	-----	Spindle Lock Spring	(1)
3c	-----	Gearcase	(1)
3d	-----	O-Ring	(1)
3e	-----	Spindle Lock Pin	(1)
3f	-----	Needle Bearing	(1)
3g	02-04-0620	Ball Bearing	(1)

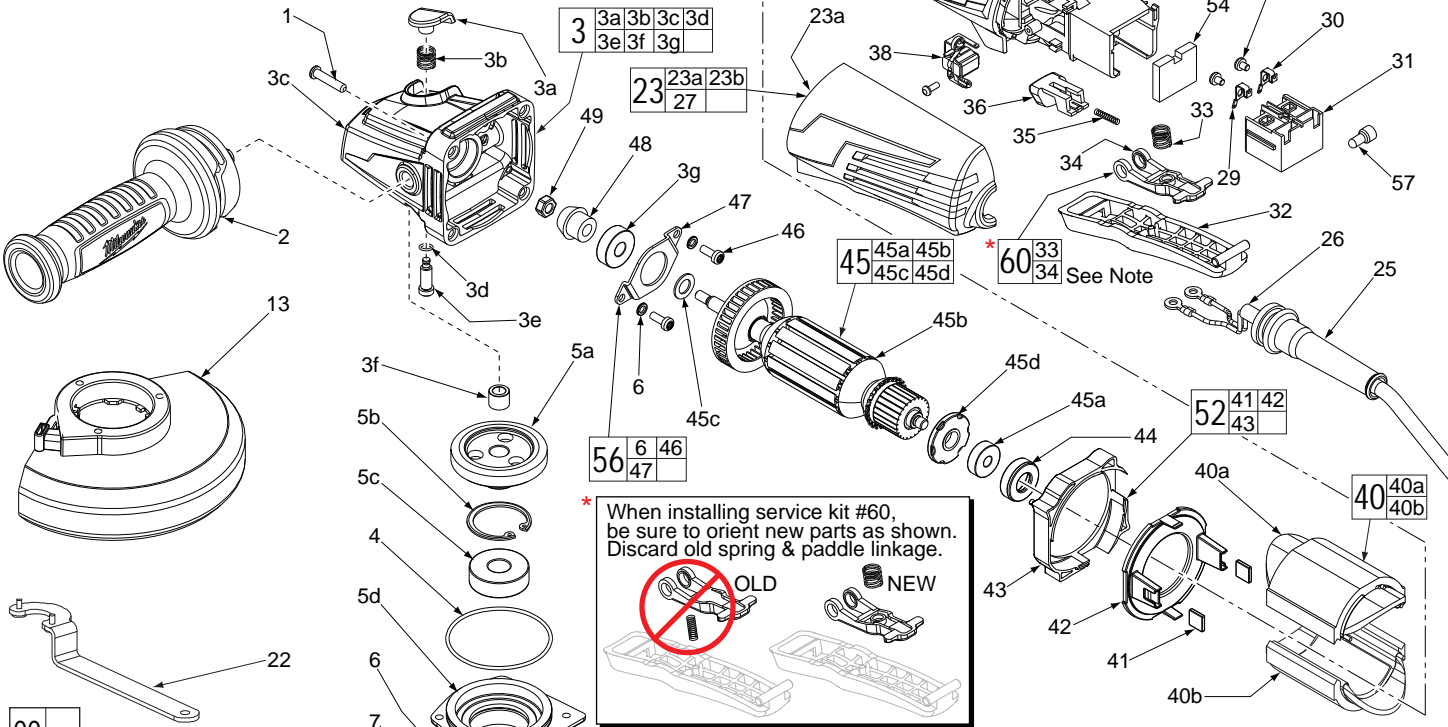

00/0

**EXAMPLE:**  
Component Parts (Small #)  
Are Included When Ordering  
The Assembly (Large #).

**\*LUBRICATION NOTE:**  
When servicing the Gears (5a & 48)  
or the Gearcase (3c), 90-95% of the  
old grease must be removed prior  
to new grease being added.

**FIG. LUBRICATION\***  
5a,48 Type "Y" Grease, No. 49-08-5270,  
Must Be Applied To All Gear Teeth.

4	34-40-0560	O-Ring	(1)
5	14-73-0425	Spindle Hub Assembly	(1)
5a	-----	Spiral Bevel Gear	(1)
5b	-----	Retaining Ring	(1)
5c	-----	Ball Bearing	(1)
5d	-----	Spindle Hub	(1)
5e	-----	5/8" Spindle	(1)
6	05-90-0225	Spring Washer	(6)
7	05-88-1210	M4 x 14mm Pan Hd. Mach. Screw T-20	(4)
13	14-32-0215	5" Type 27 Guard Assembly (Shown)	(1)
13	43-54-0925	5" Type 1 Guard Assy. (Not Shown)	(1)
15	-----	O-Ring	(1)
16	-----	Wavey Spring	(1)
17	-----	Flange with Ramps	(1)
18	-----	Retaining Ring	(1)
19	43-34-0935	Inner Disc Flange	(1)
21	44-40-0035	Outer Flange Nut	(1)
22	49-96-7205	Spanner Wrench	(1)
23	31-44-0645	Rear Handle Set	(1)
23a	-----	Left Handle Half	(1)
23b	-----	Right Handle Half	(1)
25	44-76-0095	Cord Protector	(1)
26	22-64-3430	Power Cord	(1)
27	05-88-1300	M4 x 28mm Pan Hd. ST Screw T-20	(4)

FIG.	PART NO.	DESCRIPTION OF PART	NO. REQ.
28	22-09-1865	PCB Assembly	(1)
29	23-74-1620	Terminal	(1)
30	23-74-1615	Terminal	(1)
31	23-66-2665	On-Off Switch	(1)
32	31-92-0275	Paddle Trigger	(1)
33	-----	Paddle Trigger Spring	(1)
34	-----	Paddle Linkage	(1)
35	40-50-1155	Lock Button Spring	(1)
36	42-42-0495	Lock-On Button	(1)
37	05-88-0030	M3 x 8.5mm Pan Hd. ST Screw T-10	(2)
38	22-18-2250	Carbon Brush Assembly (Set of 2)	(1)
39	31-50-2165	Motor Housing	(1)
40	18-07-0300	Field Assembly	(1)
40a	-----	Field Halve	(1)
40b	-----	Field Halve	(1)
41	42-28-0085	Rubber Block	(2)
42	-----	Baffle Foot	(1)
43	-----	Baffle	(1)
44	42-96-0016	Rubber Bearing Cap	(1)
45	16-10-0845	Armature Assembly	(1)
45a	02-04-2110	Ball Bearing	(1)
45b	-----	Armature	(1)
45c	45-88-0406	Washer	(1)
45d	-----	Magnetic Disc	(2)
46	05-88-1280	M4 x 10mm Pan Hd. Mach. Screw T-20	(2)
47	44-86-0155	Bearing Retainer	(1)
48	32-60-0310	Pinion	(1)
49	05-55-0620	M5 Hex Nut	(1)
50	14-46-6105	Flange with Ramps Assembly	(1)
52	42-14-0515	Baffle Assembly	(1)
53	05-78-0305	M3.5 x 7mm Pan Hd. Phil. Switch Scr.	(2)
54	23-16-0075	Foam Block	(1)
56	44-86-0145	Bearing Retaining Plate Assembly	(1)
57	22-56-0150	Closed End Wire Connector	(1)
60	14-46-6100	Paddle Linkage/Spring Service Kit	(1)
	12-20-1560	Service Nameplate (Not Shown)	(1)
	10-20-2225	Bi-Lingual Warning Label (Not Shown)	(1)

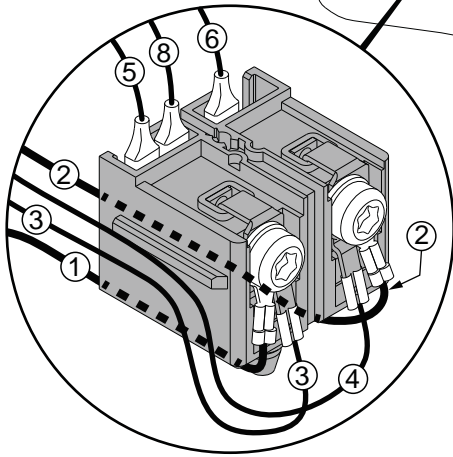
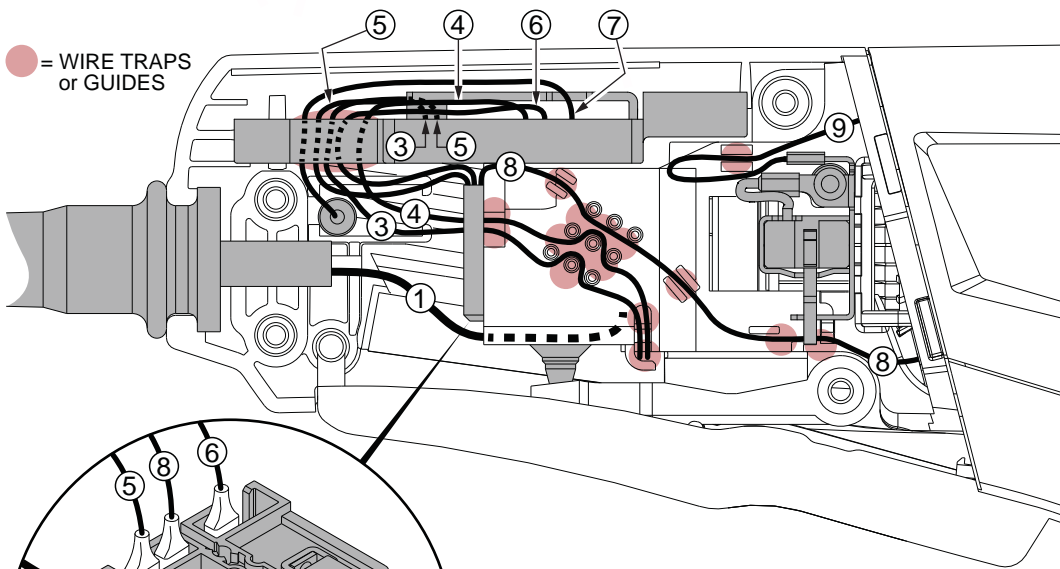

Attach all wires to the switch as shown prior to inserting switch into the motor housing. Be sure that foam block is seated in the switch opening of motor housing before switch is installed.

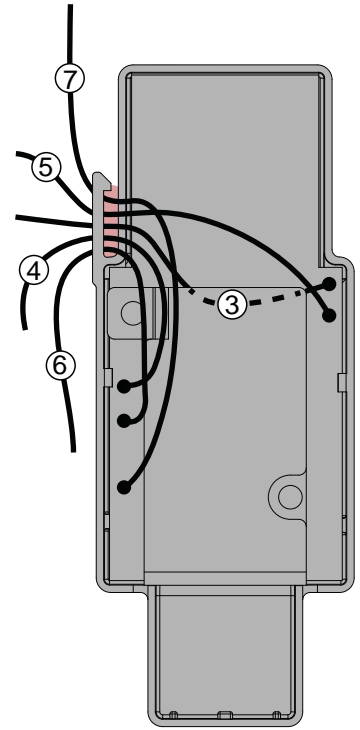
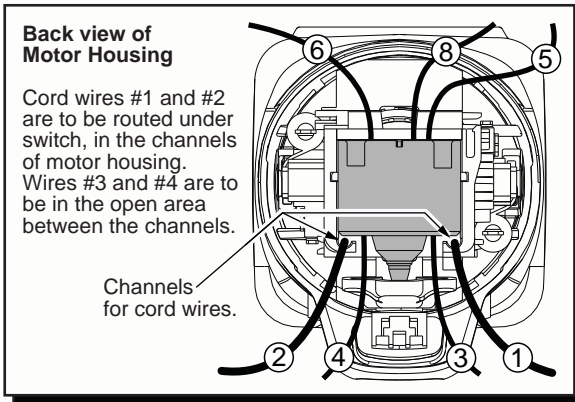

Top view of PCB Assembly

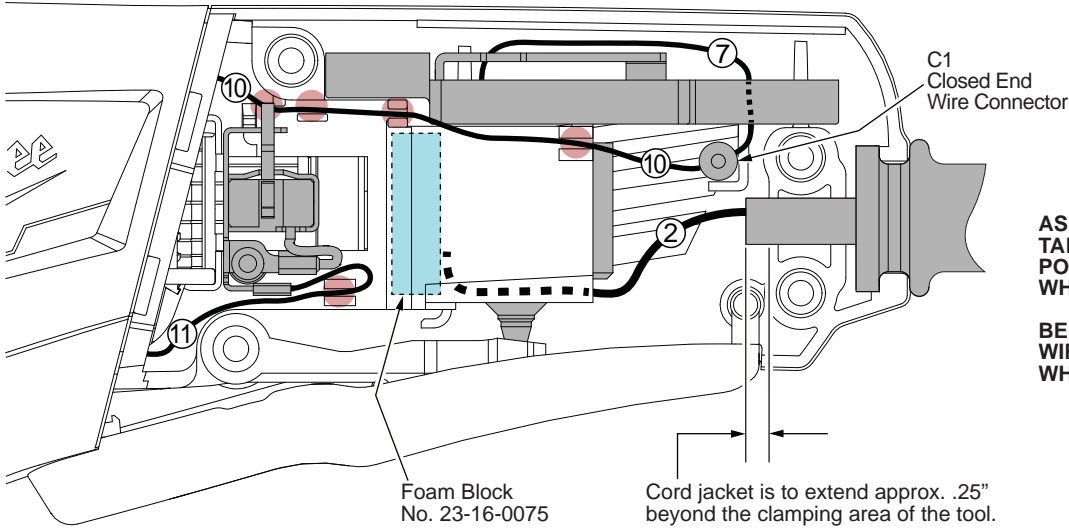

AS AN AID TO REASSEMBLY, TAKE NOTICE OF WIRE ROUTING AND POSITION IN WIRE GUIDES AND TRAPS WHILE DISMANTLING TOOL.

BE CAREFUL AND AVOID PINCHING WIRES BETWEEN HANDLE HALVES WHEN ASSEMBLING.

**WIRING SPECIFICATIONS**

Wire No.	Wire Color	Origin or Part No.	Gauge	Length	Terminals, Connectors and End Wire Preparation
1	Black	22-64-3430	--	--	Component of Cord Set. Connect to Switch.
2	White	22-64-3430	--	--	Component of Cord Set. Connect to Switch.
3	Black	22-09-1865	--	--	Component of PCBA. Connect to Switch.
4	White	22-09-1865	--	--	Component of PCBA. Connect to Switch.
5	Black	22-09-1865	--	--	Component of PCBA. Connect to Switch.
6	White	22-09-1865	--	--	Component of PCBA. Connect to Switch.
7	Red	22-09-1865	--	--	Component of PCBA. Connect to C1 with wire #10.
8	Black	18-07-0300	--	--	Component of Field. Connect to Switch.
9	Black	18-07-0300	--	--	Component of Field. Connect to Right Brush Assy.
10	Black	18-07-0300	--	--	Component of Field. Connect to C1 with wire #7.
11	Black	18-07-0300	--	--	Component of Field. Connect to Left Brush Assy.

BULK LEAD WIRE - BULLETIN 58-01-0003

**NOTE:**

All leads must be held to  $\pm 1/16"$ . All lead lengths are before strip-

**TERMINAL DESCRIPTION**

Code	Part No.	Qty.

**CONNECTOR DESCRIPTION**

C1	22-56-0150	1
----	------------	---