

SERVICE PARTS LIST

BULLETIN NO.
55-38-0354

SPECIFY CATALOG NO. AND SERIAL NO. WHEN ORDERING PARTS		REVISED BULLETIN	DATE
7" GRINDER - 8000 R.P.M.		55-38-0353	Sept. '94
CATALOG NO. 6098-2	STARTING SERIAL NO. 721-4000	WIRING INSTRUCTION 58-01-1471	

EXAMPLE:

00	0
----	---

 Component Parts (Small #) Are Included
 When Ordering The Assembly (Large #).

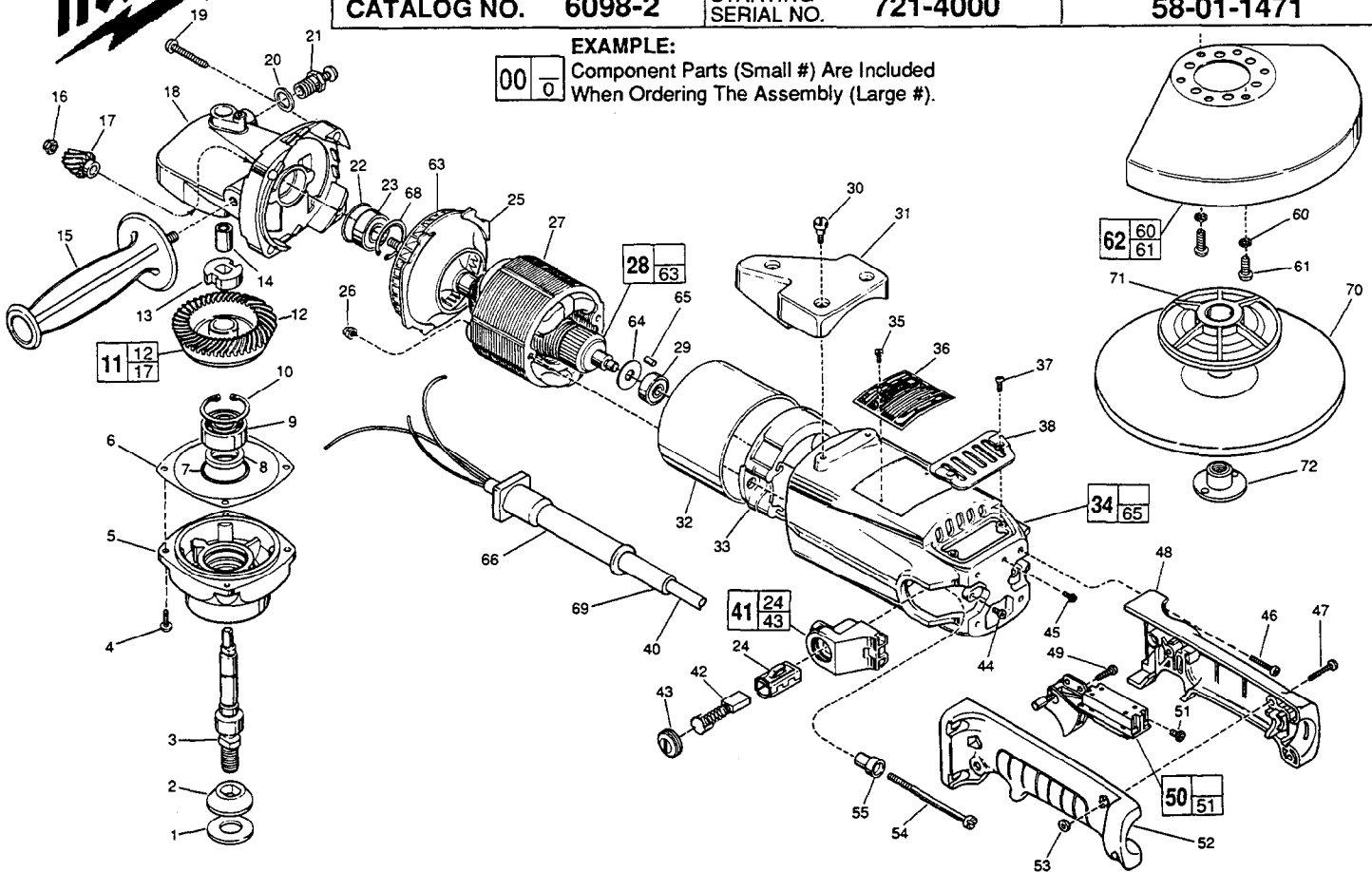

FIG.	PART NO.	DESCRIPTION OF PART	NO. REQ.
★	1	45-88-8465 Spindle Washer - Nylon	(1)
	2	49-05-0060 Washer Flange	(1)
	3	38-50-5560 Spindle Shaft	(1)
★	4	06-82-8880 10-24 x 5/8" Pan Hd. Sems T-25 Screw	(4)
	5	28-14-1735 Lower Gear Case	(1)
	6	45-14-0225 Shim - Blue .005 Thick	(1)
		45-14-0210 Shim - Red .010 Thick	(1)
★	7	34-40-1550 O-Ring	(1)
	8	45-06-0330 Felt Seal	(1)
★	9	02-04-1745 Ball Bearing	(1)
	10	34-80-2960 Retaining Ring - Internal	(1)
	11	14-46-4310 Bevel Gear Kit	(1)
	12	32-05-2211 Spiral Bevel Gear	(1)
	13	42-74-0080 Spindle Locking Cog	(1)
	14	02-50-2428 Needle Bearing	(1)
	15	43-62-0880 Side Handle	(1)
	16	06-57-5006 1/4 - 28 Locking Hex Nut	(1)
	17	32-60-1296 Spiral Bevel Pinion	(1)
	18	28-14-2035 Upper Gear Case	(1)
	19	06-82-5716 1/4-20 x 1-1/4" Pan Hd. T-30 Taptite Screw	(4)
	20	45-88-5920 Flat Washer	(1)
	21	44-20-0235 Spindle Lock Assembly	(1)
	22	34-40-1375 O-Ring	(1)
	23	02-04-1229 Ball Bearing	(1)
	24	22-20-0360 Brush Tube	(2)
	25	42-14-0300 Baffle	(1)
	26	06-57-3005 10-32 Locking Hex Nut	(2)
★	27	18-74-0260 220 Volt Field	(1)
★	28	16-74-0300 220 Volt Armature	(1)
	29	02-04-0911 Ball Bearing	(1)
	30	45-04-0720 Shoulder Screw	(3)
	31	31-70-0150 Tool Rest	(1)
	32	23-16-0950 Insulating Sleeve	(1)
	33	31-55-0110 Coil Shield	(1)
	34	28-50-6351 Motor Housing	(1)
	35	06-85-0200 Nameplate Screw	(2)
★	36	12-99-0407 Nameplate Blank	(1)
	37	06-95-3601 8-32 x 3/8" Oval Hd. Taptite Screw	(2)
	38	31-15-0310 Cover Plate	(1)

FIG.	PART NO.	DESCRIPTION OF PART	NO. REQ.
	40	22-64-4515 Cord Set	(1)
	41	22-22-0401 Brush Holder Assembly	(2)
	42	22-18-0770 Carbon Brush Assembly	(2)
	43	23-44-0170 Brush Retaining Cap	(2)
	44	06-82-7252 8-32 x 3/8" Pan Hd. T-20 Screw	(2)
	45	06-95-5200 8-32 x 5/16" Slot Hex Hd. Screw	(1)
	46	06-82-5574 10-24 x 7/8" Pan Hd. T-25 Taptite Screw	(4)
	47	06-82-2378 10-24 x 1" Pan Hd. T-25 Screw	(3)
	48	31-44-0606 Right Handle Half	(1)
	49	06-82-7409 8-16 x 1/2" Pan Hd. T-20 Plastite Screw	(1)
★	50	23-66-1845 Switch	(1)
★	51	05-78-0305 Switch Screw T-15	(2)
	52	31-44-0607 Left Handle Half	(1)
	53	06-55-1050 10-24 Hex Nut	(3)
	54	06-82-9600 10-32 x 3" Torx Hd. Screw	(2)
	55	31-86-0160 Insulating Bushing	(2)
	60	06-97-4000 1/4" Split Ring Lockwasher	(2)
	61	06-95-5630 1/4-20 x 1/2" Special Screw	(2)
★	62	49-12-0355 7" Wheel Guard Assembly	(1)
	63	22-84-0800 Fan	(1)
	64	45-06-0390 Dust Seal	(1)
	65	45-30-0070 Ball Bearing Retaining Slug	(1)
	66	44-76-0170 Cord Strain Relief	(1)
	68	34-80-2600 Internal Retaining Ring	(1)
	69	44-76-0250 Cord Protector	(1)
	70	49-94-3112 7" 24 Grit Wheel	(1)
	71	48-03-1000 Hub Adaptor	(1)
	72	49-40-0380 Wheel Nut	(1)
		49-96-7201 Spanner Wrench	(1)

FIG. NOTES
 6 As Required (Max. .015").
 13 Dimple Side To Fig. 12.
 FIG. LUBRICATION
 18 2 Oz. Type "G" Grease, No. 49-08-4140.