



# SERVICE PARTS LIST

**BULLETIN NO.**  
**54-38-1641**

<b>SPECIFY CATALOG NO. AND SERIAL NO. WHEN ORDERING PARTS</b>		REVISED BULLETIN	DATE
<b>7" / 9" GRINDER</b>		54-38-1640	Feb. 2009
<b>CATALOG NO.</b>	<b>6089-31</b>	WIRING INSTRUCTION	
	<b>SERIAL NUMBER</b>	<b>58-01-1375</b>	
	<b>B46B</b>		

**EXAMPLE:**  
Component Parts (Small #)  
Are Included When Ordering  
The Assembly (Large #).

FIG.	PART NO.	DESCRIPTION OF PART	NO REQ.
34	38-50-2500	Spindle Shaft	(1)
35	40-50-1375	Flat Spring	(1)
36	40-50-1550	Compression Spring	(1)
37	42-14-0425	Baffle	(1)
38	42-30-0150	Lock Body	(1)
39	42-42-0290	Button	(1)
40	23-82-0345	Heat Shrink Tube	(4)
41	43-34-0825	5/8 Back Flange	(1)
42	49-12-0010	7" Guard Assembly (Type 27)	(1)
42a	49-12-0020	9" Guard Assembly (Type 27)	(1)
43	43-62-1266	Side Handle	(1)
44	44-20-0502	Rotating Handle Lever	(1)
45	44-60-1650	Lock Pin	(1)
46	44-86-0040	Bearing Retainer	(1)
47	34-40-4555	O-Ring	(1)
48	45-06-0710	Seal	(1)

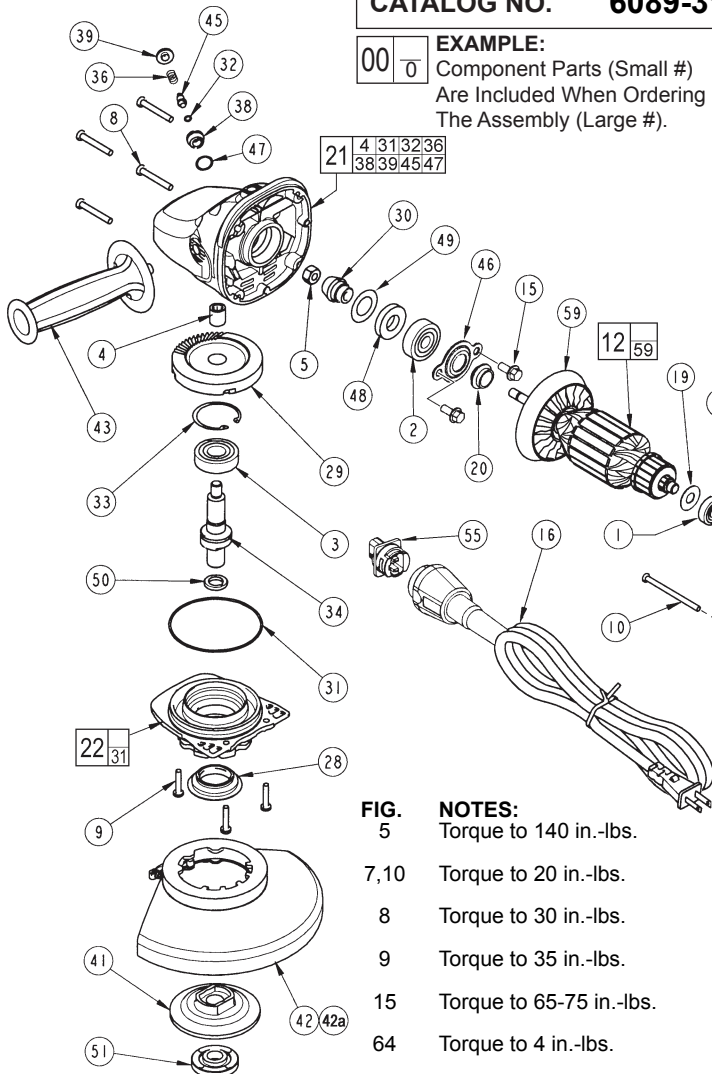

- FIG. 5** Torque to 140 in.-lbs.  
**7, 10** Torque to 20 in.-lbs.  
**8** Torque to 30 in.-lbs.  
**9** Torque to 35 in.-lbs.  
**15** Torque to 65-75 in.-lbs.  
**64** Torque to 4 in.-lbs.

### FIELD TERMINAL POCKETS

Fill cavities with Type 'X' contact grease No. 49-08-5000, 4 places.  
Do not over fill and allow grease to extend past edges.

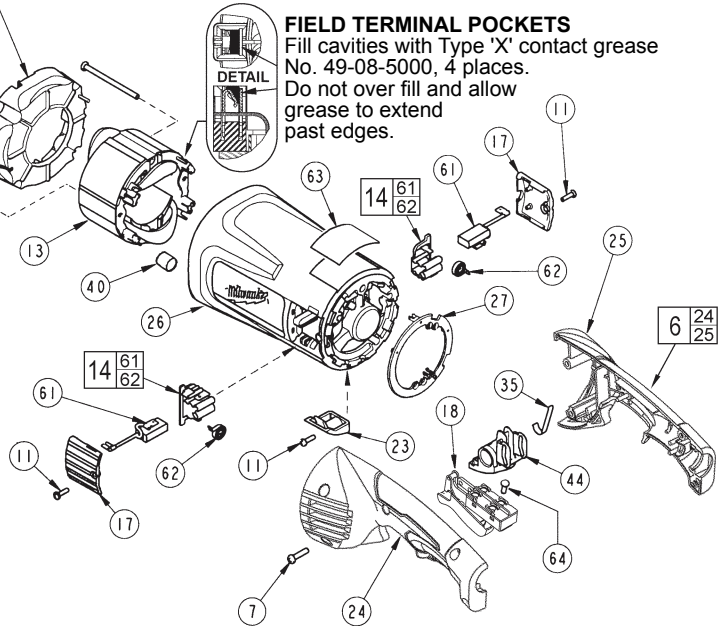

FIG.	PART NO.	DESCRIPTION OF PART	NO REQ.
1	02-04-1675	Ball Bearing	(1)
2	02-04-1680	Ball Bearing	(1)
3	02-04-1745	Ball Bearing	(1)
4	02-50-2429	Needle Bearing	(1)
5	06-55-2455	Hex Nut	(1)
6	14-34-0564	Handle Kit	(1)
7	06-82-0055	8-16 Torx Plastite Screw T-20	(5)
8	06-82-0060	10-14 Torx Plastite Screw T-25	(4)
9	06-82-0065	10-32 x 1 Pan Hd. Taprite T-25 Screw	(3)
10	06-82-0070	8-16 Torx Plastite Screw T-15	(2)
11	06-82-7240	6-19 x 1/2 Slit. Pan Hd. Plast. T-15	(3)
12	16-70-0132	Armature Assembly	(1)
13	18-70-1130	Field	(1)
14	22-20-0120	Brush Holder Assembly w/ Pop-Off	(2)
15	06-75-0510	1/4-20 x .62 Hex Flange Screw	(2)
16	48-76-5110	Quik-Lok Cord Set	(1)
17	23-44-0255	Brush Cover	(2)
18	23-66-2726	Switch	(1)
19	45-06-0830	Bearing Seal	(1)
20	31-55-0290	Dust Shield	(1)
21	28-14-1131	Gearcase Assembly	(1)
22	28-53-0151	Spindle Hub Assembly	(1)
23	31-15-0166	Cover	(1)
24	-----	Left Hand Handle Halve	(1)
25	-----	Right Hand Handle Halve	(1)
26	31-50-1785	Motor Housing	(1)
27	31-53-0160	Plug	(1)
28	31-55-0150	Bearing Shield	(1)
29	32-05-1505	Gear	(1)
30	32-60-1505	Pinion Gear	(1)
31	34-40-0505	O-Ring	(1)
32	34-40-4300	O-Ring	(1)
33	34-80-2960	Retaining Ring	(1)

FIG.	PART NO.	DESCRIPTION OF PART	NO REQ.
49	45-88-7880	Shim Washer	(1)
50	45-88-8466	5/8-11 Spindle Washer	(1)
51	49-05-0110	Flange Nut	(1)
55	22-56-1051	Blade Housing Assembly	(1)
59	22-84-0540	Fan Assembly	(1)
61	22-18-0126	Carbon Brush Assembly w/ Pop-Off	(2)
62	-----	Brush Spring	(2)
63	12-99-5008	Nameplate Blank	(1)
64	05-78-0305	Switch Screw	(4)
	23-94-9300	Leadwire Assembly (Red)	(1)
	23-94-9305	Leadwire Assembly (White)	(1)
	23-94-9310	Leadwire Assembly (Black)	(1)
	23-94-9315	Leadwire Assembly (White)	(1)
	49-96-7205	Spanner Wrench	(1)
	10-98-6085	Warning Label, French & Spanish	(1)

- FIG. LUBRICATION:**  
**21** 1.25 oz. (35 grams) of Type "Y" grease, No. 49-08-5270 in main gear cavity of gearcase.  
**29, 30** "Y" grease must be applied to all gear teeth.  
**31, 32** Lightly coat o-rings with "Y" grease prior to installation.  
**FIG. NOTES:**  
**4, 21** Press needle bearing flush ±.02 to gearcase boss face.  
**33** Bevel side of retaining ring away from bearing face.