



SERVICE PARTS LIST

BULLETIN NO.
54-38-0800

| | | | |
|--|------------------------------|----------------------------------|---------|
| SPECIFY CATALOG NO. AND SERIAL NO. WHEN ORDERING PARTS | | REVISED BULLETIN | DATE |
| 7" GRINDER - 8000 R.P.M. | | | Jan.'93 |
| CATALOG NO. 6070 | STARTING SERIAL NO. 818-1001 | WIRING INSTRUCTION 58-01-0307 | |

EXAMPLE:

| | |
|----|---|
| 00 | 0 |
|----|---|

 Component Parts (Small #) Are Included
 When Ordering The Assembly (Large #).

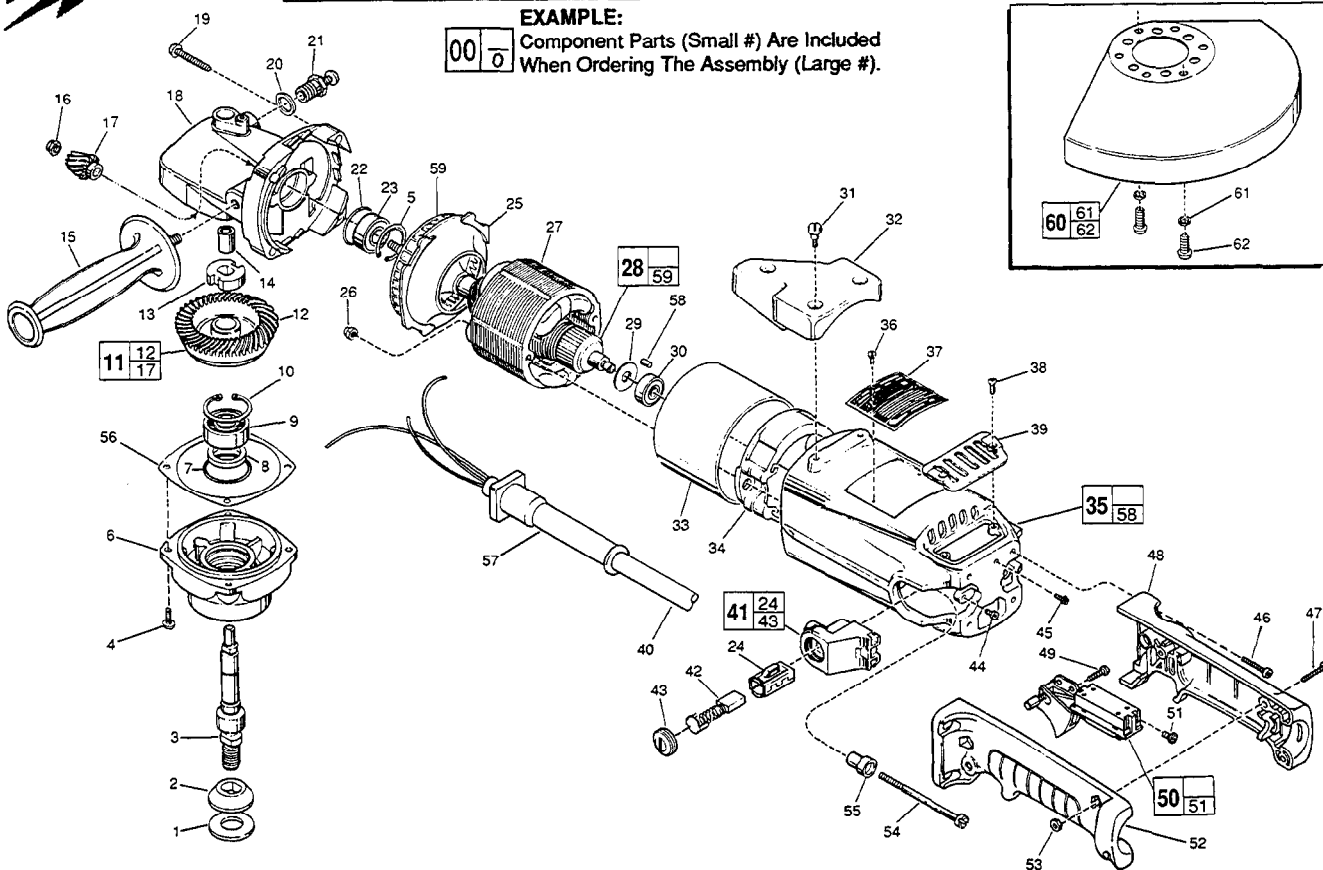
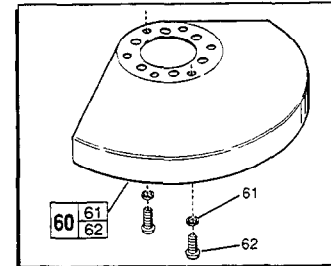

| FIG. | PART NO. | DESCRIPTION OF PART | NO. REQ. |
|------|------------|---|----------|
| 1 | 45-88-8465 | Spindle Washer - Nylon | (1) |
| 2 | 49-05-0060 | Washer Flange | (1) |
| 3 | 38-50-5560 | Spindle Shaft | (1) |
| 4 | 06-82-8864 | 10-24 x 1/2" Pan Hd. Sem T-25 Screw | (4) |
| 5 | 34-80-2600 | Internal Retaining Ring | (1) |
| 6 | 28-14-1735 | Lower Gear Case | (1) |
| 7 | 34-40-1610 | O-Ring | (1) |
| 8 | 45-06-0330 | Felt Seal | (1) |
| 9 | 02-04-1746 | Ball Bearing | (1) |
| 10 | 34-80-2960 | Retaining Ring - Internal | (1) |
| 11 | 14-46-4310 | Bevel Gear Kit | (1) |
| 12 | 32-05-2211 | Spiral Bevel Gear | (1) |
| 13 | 42-74-0080 | Spindle Locking Cog | (1) |
| 14 | 02-50-2428 | Needle Bearing | (1) |
| 15 | 43-62-0880 | Side Handle | (1) |
| 16 | 06-57-5006 | 1/4 - 28 Locking Hex Nut | (1) |
| 17 | 32-60-1296 | Spiral Bevel Pinion | (1) |
| 18 | 28-14-2035 | Upper Gear Case | (1) |
| 19 | 06-82-5716 | 1/4-20 x 1-1/4" Pan Hd. T-30 Taprite Scr. | (4) |
| 20 | 45-88-5320 | Flat Washer | (1) |
| 21 | 44-20-0235 | Spindle Lock Assembly | (1) |
| 22 | 34-40-1375 | O-Ring | (1) |
| 23 | 02-04-1229 | Ball Bearing | (1) |
| 24 | 22-20-0360 | Brush Tube | (2) |
| 25 | 42-14-0300 | Baffle | (1) |
| 26 | 06-57-3005 | 10-32 Locking Hex Nut | (2) |
| 27 | 18-70-0260 | 120 Volt Field | (1) |
| 28 | 16-70-0300 | 120 Volt Armature | (1) |
| 29 | 45-06-0390 | Dust Seal | (1) |
| 30 | 02-04-0911 | Ball Bearing | (1) |
| 31 | 45-04-0720 | Shoulder Screw | (3) |
| 32 | 31-70-0150 | Tool Rest | (1) |
| 33 | 23-16-0950 | Insulating Sleeve | (1) |
| 34 | 31-55-0110 | Coil Shield | (1) |
| 35 | 28-50-6351 | Motor Housing | (1) |
| 36 | 06-85-0200 | Nameplate Screw | (2) |
| 37 | 12-99-0406 | Nameplate Blank | (1) |
| 38 | 06-95-3601 | 8-32 x 3/8" Oval Hd. Taprite Screw | (2) |

| FIG. | PART NO. | DESCRIPTION OF PART | NO. REQ. |
|------|------------|---|----------|
| 39 | 31-15-0310 | Cover Plate | (1) |
| 40 | 22-64-3000 | Cord Set | (1) |
| 41 | 22-22-0401 | Brush Holder Assembly | (2) |
| 42 | 22-18-0730 | Carbon Brush Assembly | (2) |
| 43 | 23-44-0170 | Brush Retaining Cap | (2) |
| 44 | 06-82-7252 | 8-32 x 3/8" Pan Hd. T-20 Screw | (2) |
| 45 | 06-95-5200 | 8-32 x 5/16" Slot Hex Hd. Screw | (1) |
| 46 | 06-82-5574 | 10-24 x 7/8" Pan Hd. T-25 Taprite Screw | (4) |
| 47 | 06-82-2378 | 10-24 x 1" Pan Hd. T-25 Screw | (3) |
| 48 | 31-44-0606 | Right Handle Half | (1) |
| 49 | 06-82-7409 | 8-16 x 1/2" Pan Hd. T-20 Plastite Screw | (1) |
| 50 | 23-66-1805 | Switch | (1) |
| 51 | 05-78-0305 | Switch Screw T-15 | (4) |
| 52 | 31-44-0607 | Left Handle Half | (1) |
| 53 | 06-55-1050 | 10-24 Hex Nut | (3) |
| 54 | 06-82-9600 | Field Screw T-25 | (2) |
| 55 | 31-86-0160 | Insulating Bushing | (2) |
| 56 | 45-14-0225 | Shim - Blue .005 Thick | (1) |
| | 45-14-0210 | Shim - Red .010 Thick | (1) |
| 57 | 44-76-0170 | Cord Protector | (1) |
| 58 | 45-30-0070 | Ball Bearing Retaining Slug | (1) |
| 59 | 22-84-0800 | Fan | (1) |
| 60 | 49-12-0350 | 7" Wheel Guard Assembly | (1) |
| 61 | 06-97-4000 | 1/4" Split Ring Lockwasher | (2) |
| 62 | 06-95-5630 | 1/4-20 x 1/2" Special Screw | (2) |

FIG. 13 NOTES
 Dimple Side To Fig. 12.
 As Required (Max. .015").

FIG. 18 LUBRICATION
 2 Oz. Type "G" Grease, No. 49-08-4140.

MILWAUKEE ELECTRIC TOOL CORPORATION
 13135 W. LISBON RD., BROOKFIELD, WI 53005