



SERVICE PARTS LIST

BULLETIN NO.
54-38-0120

SPECIFY CATALOG NO. AND SERIAL NO. WHEN ORDERING PARTS		REVISED BULLETIN	DATE
7" SANDER/GRINDER			NOV. '80
CATALOG NO. 6054	STARTING SERIAL NO. 650-1001	WIRING INSTRUCTION 58-01-0307	

6000 R.P.M.
13 AMPS

FOR CAT. NO. 6054-2 (240V) TOOL USE:
16-76-0025 ARMATURE
18-76-0025 FIELD
22-64-4000 CORD SET

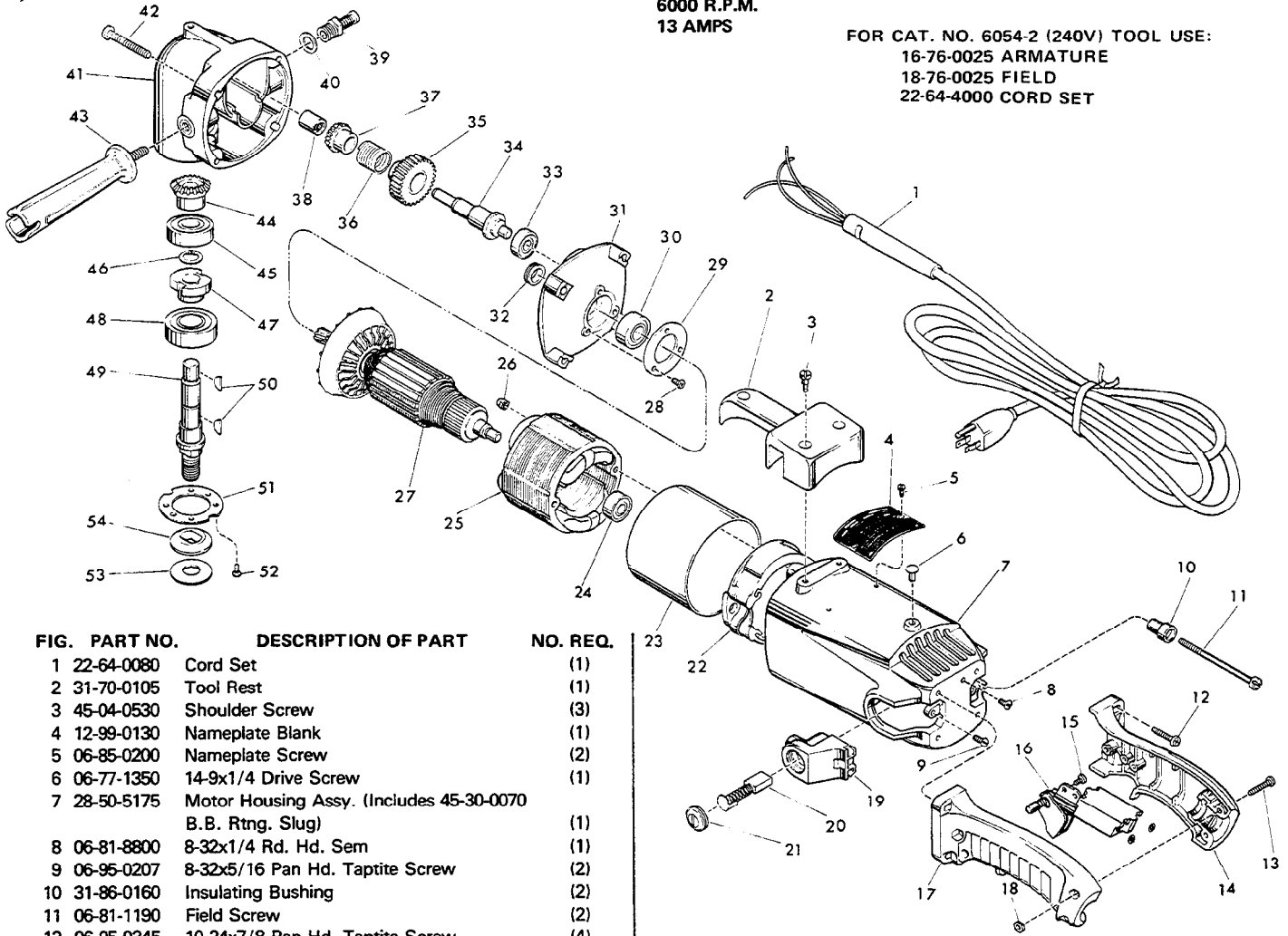

FIG.	PART NO.	DESCRIPTION OF PART	NO. REQ.
1	22-64-0080	Cord Set	(1)
2	31-70-0105	Tool Rest	(1)
3	45-04-0530	Shoulder Screw	(3)
4	12-99-0130	Nameplate Blank	(1)
5	06-85-0200	Nameplate Screw	(2)
6	06-77-1350	14-9x1/4 Drive Screw	(1)
7	28-50-5175	Motor Housing Assy. (Includes 45-30-0070 B.B. Rtnng. Slug)	(1)
8	06-81-8800	8-32x1/4 Rd. Hd. Sem	(1)
9	06-95-0207	8-32x5/16 Pan Hd. Taptite Screw	(2)
10	31-86-0160	Insulating Bushing	(2)
11	06-81-1190	Field Screw	(2)
12	06-95-0345	10-24x7/8 Pan Hd. Taptite Screw	(4)
13	06-81-4207	10-24x7/8 Phil. Pan. Hd. Screw	(3)
14	31-44-0580	Right Handle Half	(1)
15	06-95-0215	8-18x1/2 Pan Hd. Thread Form Screw	(1)
16	23-66-0255	Switch (Use (4) 06-97-1800 Lockwashers)	(1)
17	31-44-0590	Left Handle Half	(1)
18	06-55-1000	10-24 Hex Nut	(3)
19	22-22-0385	Brush Holder Assy. (Includes 22-20-0360 Brush Tube)	(2)
20	22-18-0145	Carbon Brush Assembly	(2)
21	23-44-0140	Brush Retaining Screw	(2)
22	31-55-0110	Coil Shield	(1)
23	23-16-0950	Insulating Sleeve	(1)
24	02-04-0911	Ball Bearing	(1)
25	18-70-0025	120 Volt Field	(1)
26	06-57-3005	10-32 Locking Hex Nut	(2)
27	16-70-0025	120 Volt Armature	(1)
28	06-95-0208	8-32x5/16 Taptite Screw	(3)
29	44-86-0320	Ball Bearing Retainer	(1)
30	02-04-1516	Ball Bearing	(1)
31	28-28-0391	Diaphragm Assy. (Includes 45-30-0070 B.B. Rtnng. Slug)	(1)
32	45-28-0150	Grease Slinger	(1)
33	02-04-0910	Ball Bearing	(1)

FIG.	PART NO.	DESCRIPTION OF PART	NO. REQ.
34	36-66-3310	Intermediate Shaft	(1)
35	32-40-1770	Intermediate Gear	(1)
36	40-50-3200	Clutch Spring	(1)
37	32-50-1261	Miter Gear	(1)
38	02-50-2441	Needle Bearing	(1)
39	44-20-0060	Spindle Lock Assembly	(1)
40	45-88-5320	Flat Washer	(1)
41	28-14-0615	Gear Case Assembly	(1)
42	06-95-0372	1/4-20x1-3/4 Taptite Screw	(4)
43	43-62-0760	Side Handle Assembly	(1)
44	32-50-1241	Miter Gear	(1)
45	02-04-1746	Ball Bearing	(1)
46	34-60-1290	Retaining Ring	(1)
47	42-74-0065	Spindle Locking Cog	(1)
48	02-04-2031	Ball Bearing	(1)
49	38-50-5205	Spindle Shaft	(1)
50	06-42-1600	Woodruff Key	(2)
51	45-88-0220	Spindle Retaining Washer	(2)
52	06-95-3225	8-32x3/8 Fil. Hd. Taptite Screw	(3)
53	45-88-0160	Spindle Rubber Washer	(1)
54	49-05-0060	Rubber Washer Flange	(1)

MILWAUKEE ELECTRIC TOOL CORPORATION
13135 W. LISBON RD., BROOKFIELD, WIS. 53005