



SERVICE PARTS LIST

BULLETIN NO.
54-24-1301

SPECIFY CATALOG NO. AND SERIAL NO. WHEN ORDERING PARTS		REVISED BULLETIN 54-24-1300	DATE May '83
"D" HANDLE HAMMER DRILL			
CATALOG NO. 5398	STARTING SERIAL NO. 556-14000	WIRING INSTRUCTION 58-01-0182	
CAT. NO. 5398-6	START SER. NO. 556-14000	BILINGUAL LABEL 10-98-6400	

FOR CAT. NO. 5398-2
(240V) TOOL USE:
18-36-0100 FIELD
16-36-0205 ARMATURE
22-16-0257 CARBON BRUSH
22-64-4100 CORD SET

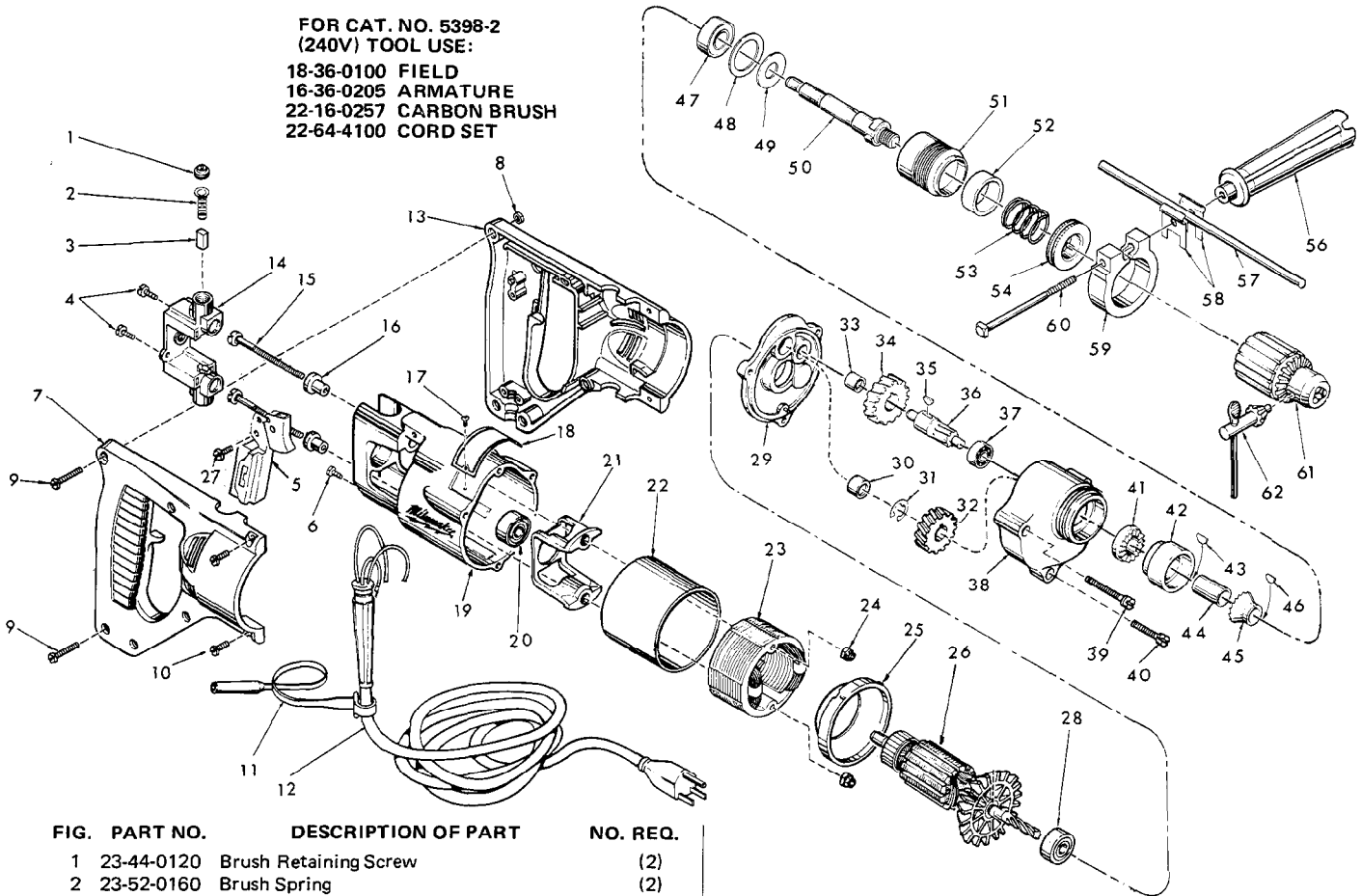

FIG.	PART NO.	DESCRIPTION OF PART	NO. REQ.
1	23-44-0120	Brush Retaining Screw	(2)
2	23-52-0160	Brush Spring	(2)
3	22-16-0250	Carbon Brush	(2)
★ 4	06-95-0116	6-32 x 5/8" Pan Hd. Taptite Screw	(2)
5	23-66-0505	Switch	(1)
★ 6	06-95-5150	Ground Screw	(1)
★ 7	31-44-0562	R.H. Half D Handle	(1)
★ 8	06-55-0835	8-32 Hex Nut	(5)
★ 9	06-81-0473	8-32 x 1" Pan Hd. Pozidriv Screw	(5)
★ 10	06-95-0700	8-32 x 1/2" Pan Hd. Taptite Screw	(4)
11	48-66-4040	Key Holder	(1)
★ 12	22-64-0405	Cord Set	(1)
★ 13	31-44-0572	L.H. Half D Handle	(1)
14	22-22-0302	Brush Holder Assembly	(1)
15	06-81-1055	8-32x2-3/16 Field Bolt	(2)
16	31-86-0120	Insulating Spacer	(2)
17	06-85-0200	6x1/4 Rd. Hd. Type Z Screw	(2)
18	12-99-0032	Nameplate	(1)
19	28-50-6147	Motor Housing	(1)
20	02-04-0891	Ball Bearing	(1)
21	31-55-0030	Coil Shield	(1)
22	23-16-0456	Field Insulator	(1)
23	18-30-0100	120 V. Field	(1)
24	06-57-2975	8-32 Flexlock Hex Nut	(2)
25	31-05-0050	Baffle	(1)
26	16-30-0210	120 V. Armature	(1)
★ 27	06-95-0215	8-18x1/2 Thread Form Screw	(1)
28	02-04-0940	Ball Bearing	(1)
29	28-28-0582	Diaphragm	(1)
30	02-50-2110	Needle Bearing	(1)
31	34-60-1000	Retaining Ring	(1)
32	32-75-2001	Spindle Gear	(1)
33	02-50-1640	Needle Bearing	(1)
34	32-40-1241	Intermediate Gear	(1)
35	06-42-0800	Woodruff Key	(1)

FIG.	PART NO.	DESCRIPTION OF PART	NO. REQ.
36	36-66-2701	Intermediate Shaft	(1)
37	02-04-0640	Ball Bearing	(1)
38	28-14-0687	Gear Case	(1)
39	06-81-6707	8-32x1-7/8 Fil. Hd. Sem	(2)
40	06-81-6402	8-32x1-1/8 Fil. Hd. Sem	(1)
41	44-84-0100	Fixed Ratchet	(1)
42	42-52-0250	Bearing Housing	(1)
43	06-42-1200	Woodruff Key	(1)
44	45-36-0890	Spacer	(1)
45	44-84-0110	Rotating Ratchet	(1)
46	06-42-0800	Woodruff Key	(1)
47	02-04-1560	Ball Bearing	(1)
48	45-88-7350	Bearing Retaining Washer	(1)
49	45-88-7360	Spring Support Washer	(1)
50	38-50-5150	Spindle	(1)
51	45-22-0405	Sleeve	(1)
52	45-88-7375	Felt Washer	(1)
53	40-50-4950	Spring	(1)
54	42-76-0200	Locking Collar	(1)
55	14-34-0250	Side Handle Assy. (Incl. Fig. Nos. 56 thru 60)	(1)
56	43-62-0700	Side Handle	(1)
57	44-94-0161	Depth Gauge Rod	(1)
58	42-68-0390	Clamp	(2)
59	28-82-0150	Handle Ring	(1)
60	42-32-0160	Bolt	(1)
61	48-66-1280	1/2" Chuck (Incl. Fig. No. 62)	(1)
62	48-66-3280	Chuck Key	(1)
63	10-98-5987	Caution Label (Not Shown) Omit For Canadian Tools	

MILWAUKEE ELECTRIC TOOL CORPORATION
13135 W. LISBON RD., BROOKFIELD, WIS. 53005