



# SERVICE PARTS LIST

**BULLETIN NO.**  
**54-24-0246**

<b>SPECIFY CATALOG NO. AND SERIAL NO. WHEN ORDERING PARTS</b>		<b>REVISED BULLETIN</b>	<b>DATE</b>
<b>3/8" PISTOL HAMMER DRILL</b>		54-24-0245	Dec.'93
<b>CATALOG NO.</b>	<b>STARTING SERIAL NO.</b>	<b>WIRING INSTRUCTION</b>	
5392-1	665B	58-01-0023	

**EXAMPLE:**

Component Parts (Small #) Are Included  
When Ordering The Assembly (Large #).

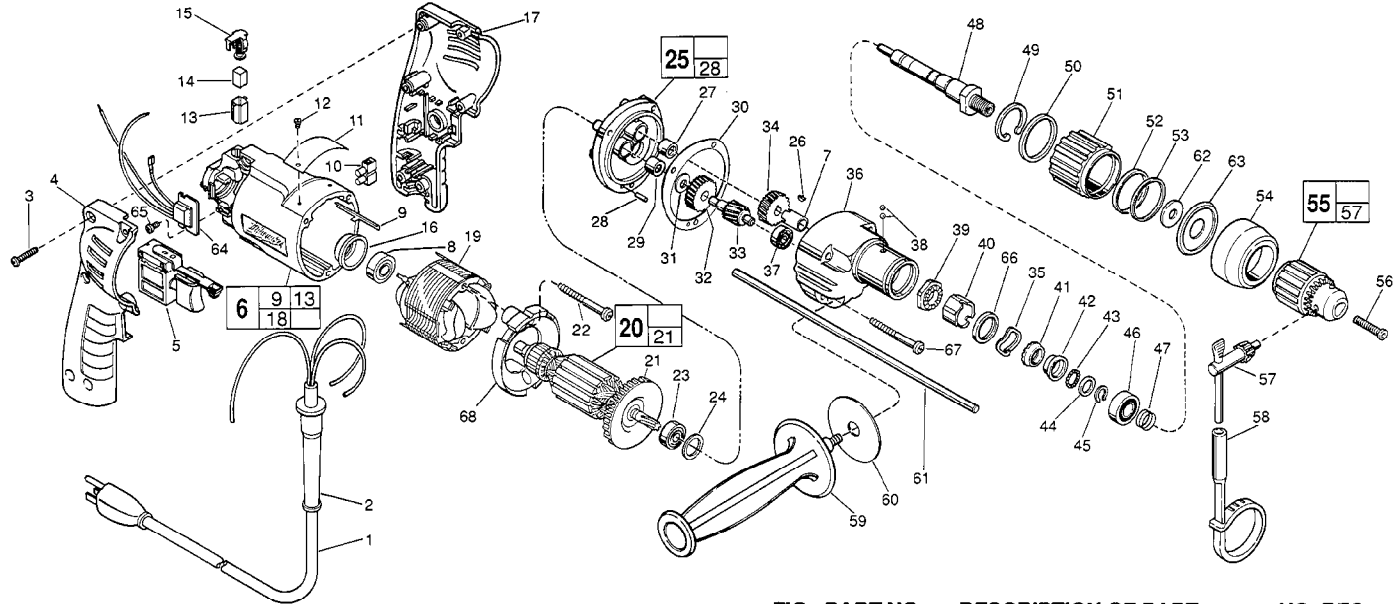

FIG.	PART NO.	DESCRIPTION OF PART	NO. REQ.
	1	22-64-1120 Cord Set	(1)
	2	44-76-0210 Cord Protector	(1)
	3	06-82-7284 8-16 x 3/4" Pan Hd. Slit. Plast. T-20	(6)
	4	31-44-1745 Right Handle Half	(1)
	5	23-66-2145 Speed Control Switch	(1)
	6	14-38-0600 Motor Housing Assembly	(1)
	7	45-36-1260 Gear Spacer	(1)
	8	02-04-0645 Ball Bearing	(1)
	9	44-60-0530 Ground Pin	(1)
	10	22-56-0456 Terminal Block	(1)
	11	12-99-0850 Service Nameplate	(1)
	12	06-85-0200 Nameplate Screw	(2)
	13	22-20-0830 Brush Tube	(2)
	14	22-16-0275 Carbon Brush	(2)
	15	23-52-1560 Brush Spring Assembly	(2)
	16	22-72-0100 Bearing Cup	(1)
	17	31-44-1740 Left Handle Half	(1)
	18	23-94-6225 Ground Wire Assembly (Not Shown)	(1)
	19	18-11-0150 120 Volt Field	(1)
★	20	16-10-0680 120 Volt Armature	(1)
★	21	22-84-0880 Fan Assembly	(1)
★	22	06-82-7203 7-18 x 2-1/8" Pan Hd. Slit. Piast. T-20	(2)
	23	02-04-0848 Ball Bearing	(1)
	24	45-88-0355 Fiber Washer	(1)
	25	28-28-1980 Diaphragm Assembly	(1)
	26	06-42-0400 Woodruff Key	(1)
	27	02-50-1611 Needle Bearing	(1)
	28	06-65-0800 Groove Pin	(1)
	29	02-50-1640 Needle Bearing	(1)
	30	43-44-0900 Gasket	(1)
	31	45-88-7721 Thrust Washer	(1)
	32	32-40-1940 Intermediate Gear	(1)
	33	36-66-4360 Intermediate Pinion Shaft	(1)
	34	32-75-3175 Spindle Gear	(1)
	35	45-88-0940 Overlap Wave Washer	(1)
	36	28-14-2100 Gear Case	(1)
	37	02-04-0640 Ball Bearing	(1)
	38	02-02-0180 3/16" Steel Ball	(6)
	39	44-84-0240 Fixed Ratchet	(1)
	40	45-36-1225 Bearing Spacer	(1)
	41	44-84-0235 Rotating Ratchet	(1)
	42	45-36-1215 Shift Spacer	(1)

FIG.	PART NO.	DESCRIPTION OF PART	NO. REQ.
	43	02-02-0120 1/8" Steel Ball	(15)
	44	45-88-0935 Thrust Washer	(1)
	45	34-60-0920 Retaining Ring	(1)
	46	02-08-0510 Ball Bearing	(1)
	47	40-50-0220 Compression Spring	(1)
	48	38-50-5515 Spindle	(1)
	49	34-80-2020 Internal Retaining Ring	(1)
	50	34-40-4040 O-Ring	(1)
	51	31-58-0055 Locking Collar	(1)
	52	34-40-1500 O-Ring	(1)
	53	34-60-2125 Retaining Ring	(1)
	54	49-62-0090 Hammer Dust Shield	(1)
	55	48-66-0795 3/8" Chuck	(1)
	56	45-04-0750 Chuck Screw	(1)
	57	48-66-3240 Chuck Key	(1)
	58	48-66-4040 Key Holder	(1)
	59	43-62-0905 Side Handle	(1)
	60	45-88-7930 Washer	(1)
	61	44-94-0161 Depth Rod	(1)
	62	45-88-1040 Washer	(1)
	63	44-86-0510 Retainer	(1)
	64	14-20-0650 Remote Electronic Assembly	(1)
	65	06-82-7212 4-20x1/4" Pan Hd. Plast. T-10	(1)
	66	45-36-1255 Flanged Spacer	(1)
	67	06-82-7393 7-18 x 2" Pan Hd. Slit. Plast. T-20	(3)
★	68	42-14-0380 Baffle	(1)

**FIG. NOTES**

- 23 Press flush to casting surface. Seal towards armature.
- 56 Apply type 242 blue loctite and torque to 40-45 in./lbs.
- 16 Place in motor housing before inserting armature.
- 8 Seal towards armature.
- 27,29 Press flush to casting surface.
- 27 Press only on end with manufacturer ID.
- 3 Torque to 18-22 In./Lbs.
- 65 Torque to 3-5 In./Lbs.
- 22 Torque field screws to 15-20 In./Lbs.
- Torque gear case screws to 30-38 In./Lbs.

**FIG. LUBRICATION**

- 36 1-1/2 oz. type "K" grease, No. 49-08-4161.
- 39,41 1/2 tsp. type "K" grease, No. 49-08-4161.
- 42,43 1/4 tsp. type "K" grease, No. 49-08-4161.
- 50,52 Coat with type "K" grease, No. 49-08-4161.

**MILWAUKEE ELECTRIC TOOL CORPORATION**  
13135 W. LISBON RD., BROOKFIELD, WI 53005