



# SERVICE PARTS LIST

**BUL. 54-24-1504**

## HAMMER DRILL

REVISED BUL 54-24-1503 DATE July '72

**Catalog No. 5390**

Starting Serial No. **422-20699**

WIRING INSTR. **58-01-0050**

Both Model and Serial No. must be furnished to obtain correct parts.

2500 R.P.M.

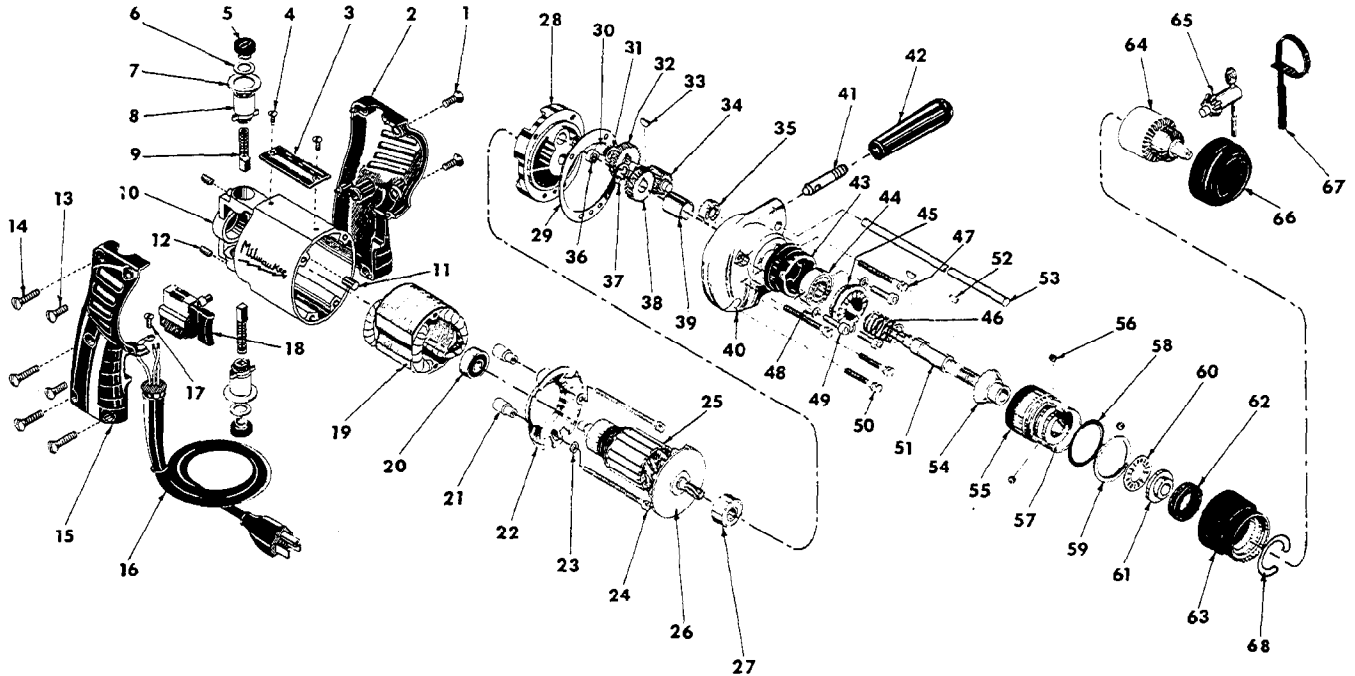

FIG.	PART NO.	DESCRIPTION OF PART	NO. REQ.	FIG.	PART NO.	DESCRIPTION OF PART	NO. REQ.
1	06-81-0450	8-32x3/8 Pan Hd. Screw	(2)	35	02-04-0640	Ball Bearing	(1)
2	31-44-0211	L. H. Handle Half	(1)	36	02-50-1610	Needle Bearing	(1)
★ 3	12-99-0023	Nameplate	(1)	37	34-60-0800	Retaining Ring	(1)
4	06-85-0200	6x1/4 Rd. Hd. Type Z Screw	(2)	38	32-75-2711	Spindle Gear	(1)
5	23-44-0060	Brush Retaining Screw	(2)	39	45-36-0611	Spindle Spacer	(1)
6	23-86-0050	Washer	(2)	★ 40	28-14-1322	Gear Case Assembly	(1)
★ 7	23-86-0105	Washer	(2)	★ 41	45-58-0220	Clamping Stud	(1)
8	22-22-0271	Brush Holder Assembly	(2)	★ 42	43-62-0465	Handle	(1)
9	22-18-0410	Split Carbon Brush Assembly	(2)	43	31-86-0111	Spacer	(1)
10	28-50-6091	Motor Housing (Includes Fig. 11)	(1)	44	02-08-0510	Ball Bearing	(1)
11	45-30-0120	Ball Brg. Retaining Slug	(1)	45	44-84-0071	Fixed Ratchet	(1)
12	06-83-2430	10-32x1/4 Hdls. Skt. Screw	(2)	46	40-50-7680	Ratchet Spring	(1)
13	06-81-0450	8-32x3/8 Pan Hd. Screw	(2)	47	06-81-6740	8-32x2 Fil. Hd. Sem	(2)
14	06-81-0400	8-32x3/4 Pan Hd. Screw	(4)	48	06-97-3200	Lock Washer	(3)
15	31-44-0200	R. H. Handle Half	(1)	49	06-75-2060	8-32x5/8 Soc. Hd. Cap Screw	(3)
16	22-64-0450	Cord Set	(1)	50	06-81-6500	8-32x1-3/8 Fil. Hd. Sem	(2)
17	06-81-8625	6-32x1/4 Ground Screw	(1)	51	38-50-5013	Spindle	(1)
18	23-66-0510	Switch	(1)	52	06-42-0800	Woodruff Key	(2)
19	18-22-1160	115 V. Field	(1)	53	44-94-0161	Depth Rod	(1)
20	02-04-0740	Ball Bearing	(1)	54	44-84-0066	Rotating Ratchet	(1)
21	45-36-0601	Baffle Spacer	(1)	55	45-22-0281	Sleeve	(1)
22	31-05-0010	Baffle	(2)	56	02-02-0180	3/16 Inch Steel Ball	(3)
23	45-88-7170	Washer	(2)	57	45-36-0592	Shift Spacer	(1)
24	06-81-8695	6-32x2-7/16 Rd. Hd. Sem	(2)	58	34-40-1500	O-Ring	(1)
25	16-22-1290	115 V. Armature (Includes Fig. 26)	(1)	59	34-60-2125	Retaining Ring	(1)
26	22-84-0440	Fan Assembly	(1)	60	02-80-1200	Thrust Bearing	(1)
27	02-04-0880	Ball Bearing	(1)	61	45-36-0621	Thrust Spacer	(1)
28	28-28-1441	Diaphragm	(1)	62	45-06-0160	Felt Seal	(1)
29	43-44-0280	Gasket	(1)	63	42-76-0181	Shift Collar Assembly	(1)
30	02-50-1210	Needle Bearing	(1)	64	48-66-0810	3/8" Chuck-3/8-24 Thread (Includes Fig. 65)	(1)
31	45-88-7160	Thrust Washer	(1)	65	48-66-3240	Chuck Key	(1)
32	32-40-1041	Intermediate Gear	(1)	66	49-62-0090	Hammer Dust Shield	(1)
33	06-42-0400	Woodruff Key	(1)	67	48-66-4040	Key Holder	(1)
34	36-66-4091	Intermediate Pinion Shaft	(1)	★ 68	44-86-0190	Retainer	(1)