



# SERVICE PARTS LIST

**BULLETIN NO.**  
**54-24-5381**

SPECIFY CATALOG NO. AND SERIAL NO. WHEN ORDERING PARTS		REVISED BULLETIN	DATE
<b>1/2" HAMMER-DRILL</b>		54-24-5380	Sept. 2010
CATALOG NO.	5380-21	WIRING INSTRUCTION	
STARTING SERIAL NO.	B01B	<b>58-01-5381</b>	

**EXAMPLE:**  
00 0 Component Parts (Small #)  
Are Included When Ordering  
The Assembly (Large #).

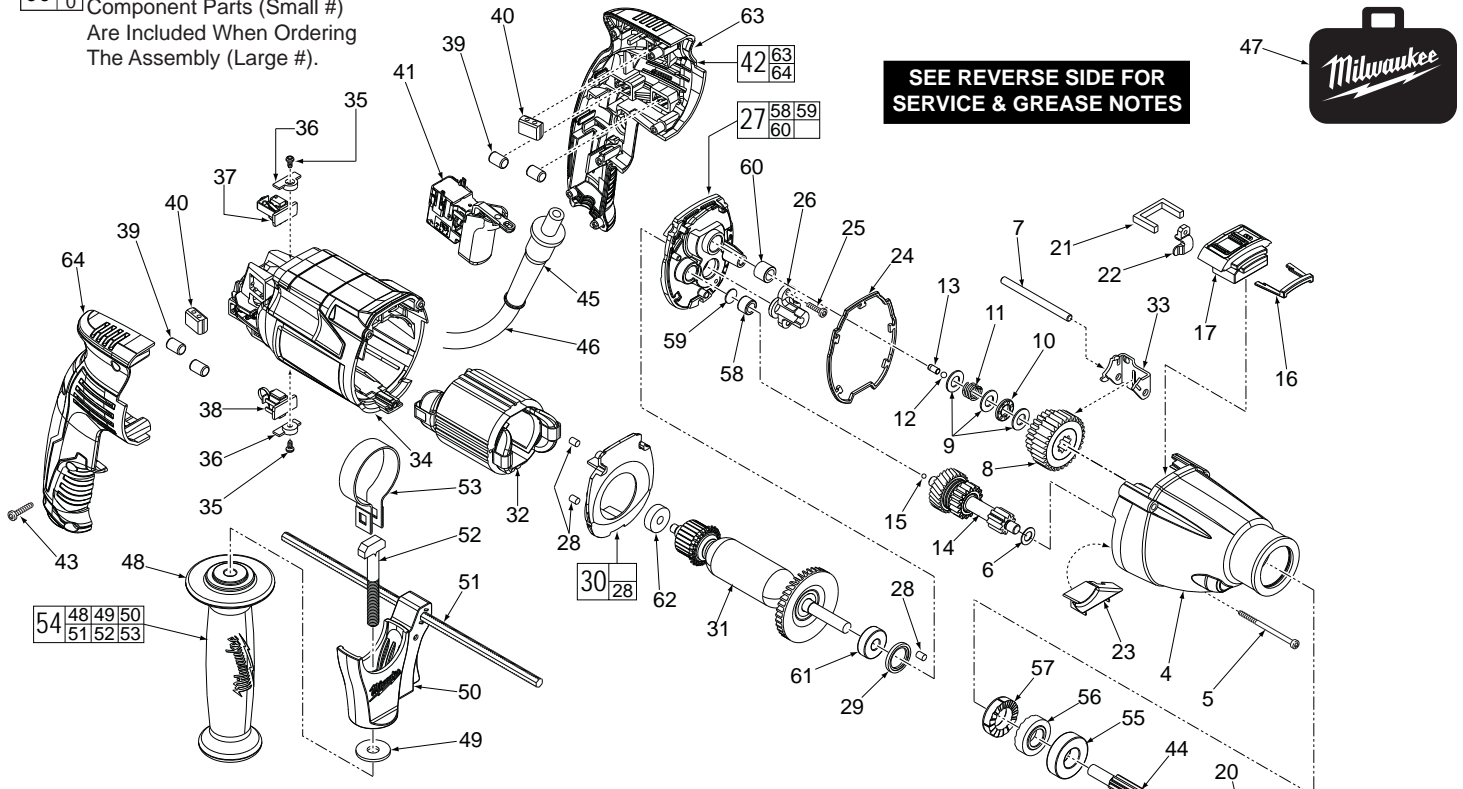

FIG.	PART NO.	DESCRIPTION OF PART	NO. REQ.
1	05-88-1500	M6 x 27 Chuck Screw	(1)
2	48-66-3280	Chuck Key	(1)
3	48-66-1355	Chuck	(1)
4	28-14-5380	Gearcase Assembly (Incl. Needle Bearing and Shifting Assy.)	(1)
5	06-81-5380	M4 x 52 ST T-20 Screw	(3)
6	45-88-5381	Washer	(1)
7	44-94-5380	Pin	(1)
8	14-29-5380	1st and 2nd Spindle Gear Assembly	(1)
9	45-88-5378	Washer	(3)
10	02-80-5380	Thrust Bearing	(1)
11	40-50-5380	Spring	(1)
12	02-02-5380	Ball	(1)
13	44-60-5381	Pin	(1)
14	14-29-5381	Gear Shaft Assembly	(1)
15	02-02-0165	Ball	(1)
16	43-44-5381	Rubber Seal	(1)
17	14-34-5382	Selector Housing Assembly	(1)
18	34-80-5380	Retaining Ring	(1)
19	43-44-5380	Seal	(1)
20	45-88-5380	Washer	(1)
21	43-44-5378	Felt Seal	(1)
22	43-96-5380	Speed Selector Key	(1)
23	44-66-5381	Grease Plate	(1)
24	43-44-5379	Gasket	(1)
25	05-88-5380	M3.5 x 12 T-10 Screw	(2)
26	42-36-5380	Pinion Support	(1)
27	28-14-5378	Diaphragm Assembly	(1)
28	42-34-5380	Rubber Slug	(3)
29	43-44-5377	Seal Ring	(1)
30	14-34-5383	Baffle Assembly	(1)
31	16-10-5380	Service Armature Assembly	(1)
32	18-07-5380	Service Field	(1)
33	44-66-5378	Shifting Clip	(1)
34	31-50-5380	Motor Housing	(1)
35	06-81-5381	M3 x 6 Pan Hd. Phillips Screw	(2)
36	44-66-5379	Brush Holder Retaining Plate	(2)
37	22-22-5380	Brush Assy.-w/pop-off (Incl. Spring & Holder)	(1)
38	22-22-5381	Brush Assy.-regular (Incl. Spring & Holder)	(1)
39	44-60-5379	Roller Pin	(4)

Apply a drop of Blue Loctite® thread locking adhesive to chuck screw (1) prior to installing onto spindle (44).

FIG.	PART NO.	DESCRIPTION OF PART	NO. REQ.
40	42-28-5380	Anti-Vibration Block	(2)
41	23-66-5380	Switch	(1)
42	14-34-5380	Rear Handle Assembly	(1)
43	05-88-1200	M4 x 16 Pan Hd. T-20 Screw	(7)
44	38-50-5380	Spindle Shaft	(1)
45	44-76-0210	Cord Protector	(1)
46	22-64-5380	Cord Set	(1)
47	42-55-5380	Carrying Case	(1)
48	31-05-5379	Side Handle	(1)
49	45-88-5377	Washer	(1)
50	14-34-5374	Side Handle Carrier Assembly	(1)
51	44-94-5381	Depth Gauge	(1)
52	05-81-5378	M8 x 53 Bolt	(1)
53	40-50-5377	Side Handle Clamping Band	(1)
54	14-34-5379	Side Handle Assembly	(1)
55	02-04-5380	Ball Bearing	(1)
56	44-84-5380	Rotating Ratchet	(1)
57	44-84-5381	Fixed Ratchet	(1)
58	-----	Needle Bearing	(1)
59	-----	Disc	(1)
60	-----	Needle Bearing	(1)
61	02-04-5381	Ball Bearing	(1)
62	02-04-5382	Ball Bearing	(1)
63	-----	Left Handle Halve	(1)
64	-----	Right Handle Halve	(1)
	12-20-5381	Service Nameplate Kit (Not Shown)	(1)
	48-66-4040	Chuck Key Holder (Not Shown)	(1)
	23-94-5381	Red Brush Leadwire Assembly (Not Shown)	(1)
	23-94-5380	Black Brush Leadwire Assy. (Not Shown)	(1)

## Service Notes

**DO NOT** attempt to disassemble selector housing assembly (17).

**NOTE:** Gasket (24), selector housing assembly (17), speed selector key (22), rubber seal (16) and felt seal (21) must be assembled onto the diaphragm assembly (27) prior to installing onto gearcase assembly (4).

1. Place gasket (24) onto diaphragm assembly (27).
- 2a. Assemble speed selector key (22) onto selector housing assembly (17). The speed selector key will be seated on a pin in a like-shaped cavity of the selector housing assembly.
- 2b. Saturate felt seal (21) with a lightweight oil and place in selector housing assembly (17) over selector key (22).
- 2c. Place rubber seal (16) onto other side of selector housing assembly (17).
- 2d. Orient the selector housing assembly (17) and the assembled components (16, 21 and 22) above the diaphragm assembly (27). All element should slide straight down onto the diaphragm with the speed selector key (22) sliding into slotted opening.
3. Assemble above listed parts onto gearcase assembly (4).

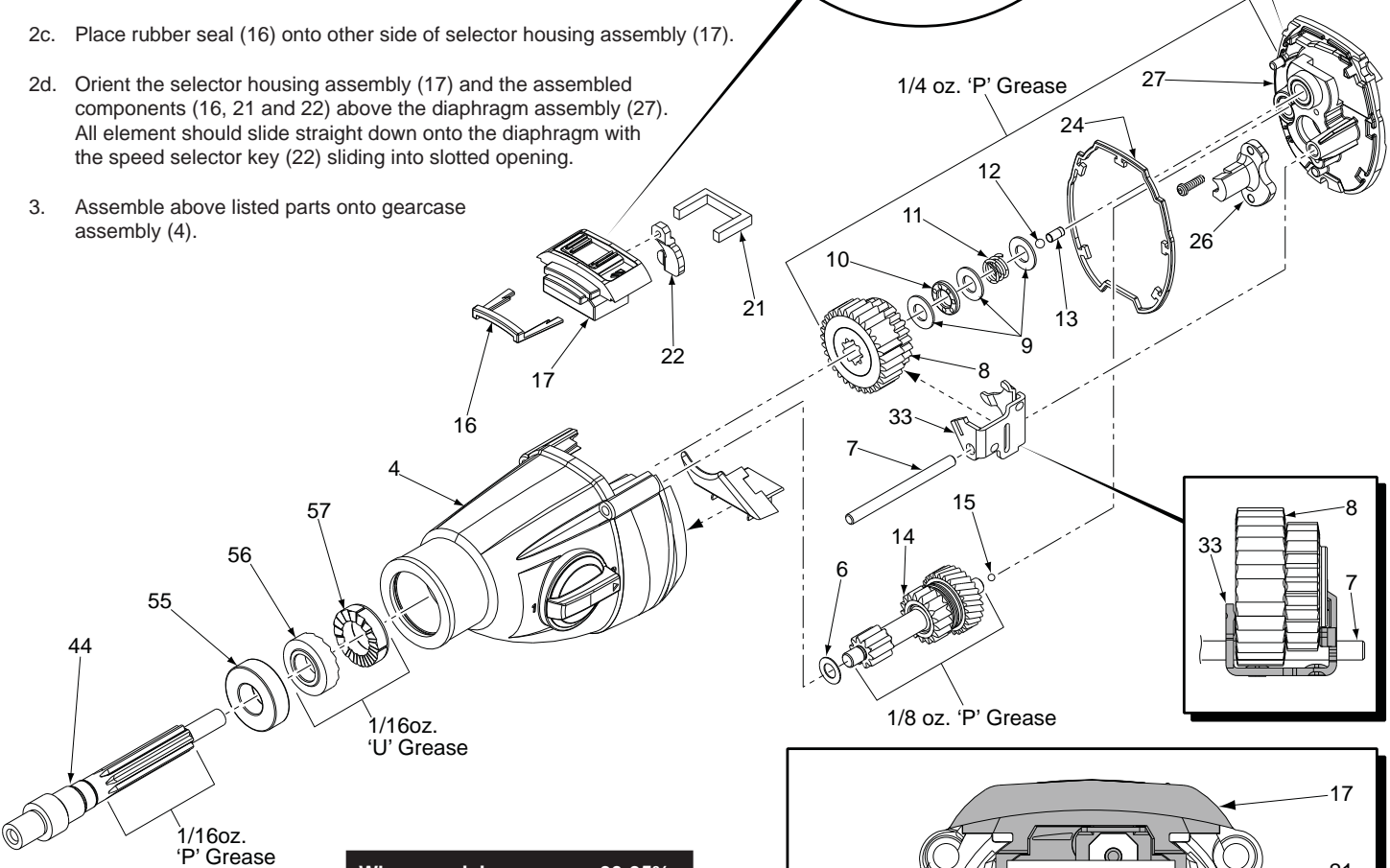
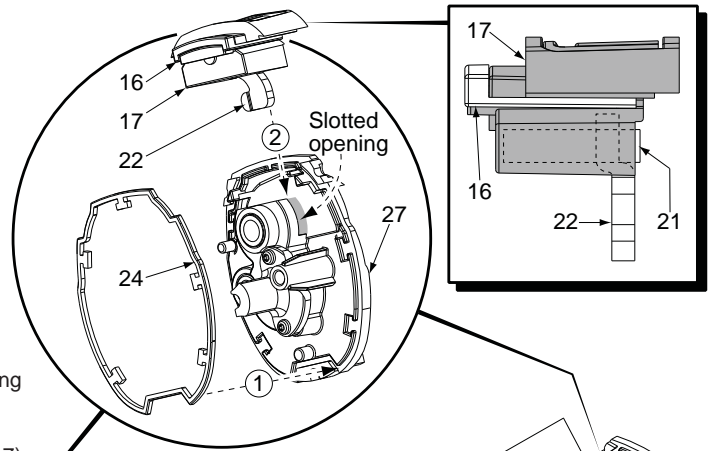

## Lubrication Instructions

Type "P" (49-08-4250)  
Type "U" (49-08-0150)

**When servicing, remove 90-95% of the existing grease prior to installing Type 'P' grease. Original grease maybe similar in color but not compatible with 'P'.**

1. Coat ratchets (56,57) with 1/16 oz. of Type "U" grease, No. 49-08-0150.
2. Coat spindle spline (44), ball (12) and pin (13) with 1/16 oz. of Type "P" grease, No. 49-08-4250.
3. Place 1/8 oz. of Type "P" grease, No. 49-08-4250, around the gear shaft assembly (14) area of gearcase (4) .
4. Lubricate gear assembly (parts 6,7,8,9,10,11,12,13,14,15,24,25,26,33,58, 59 and 60) using 1/4 oz. of Type "P" grease, No. 49-08-4250.

Total amount of lubrication: approximately 1/2 oz.

Saturate felt seal (21) with lightweight oil before assembling onto selector housing assembly (17).

Do not place gear shaft assembly (14) in solvent solution. Wipe off with a clean dry cloth.

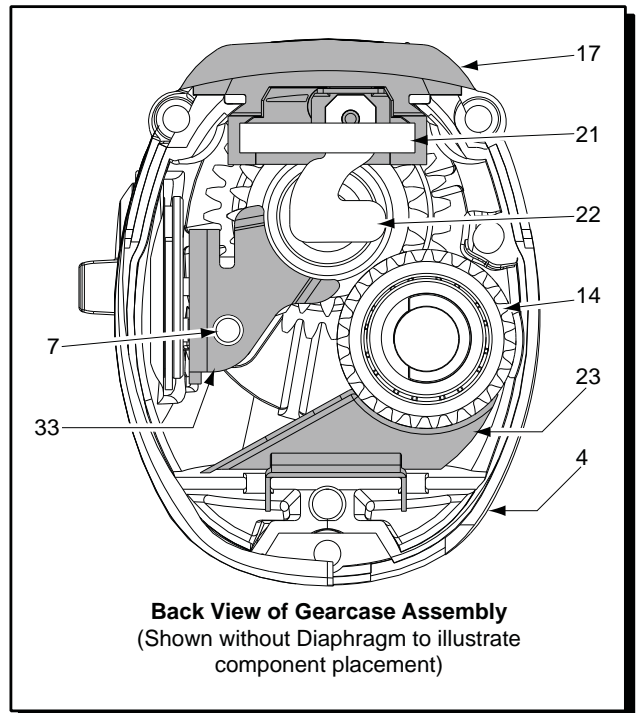

**Back View of Gearcase Assembly**  
(Shown without Diaphragm to illustrate component placement)