



SERVICE PARTS LIST

BULLETIN NO.
54-24-0134

SPECIFY CATALOG NO. AND SERIAL NO. WHEN ORDERING PARTS		REVISED BULLETIN 54-24-0133	DATE Nov. 2003
1" HAWK ROTARY HAMMER		WIRING INSTRUCTION 58-01-0736	
CATALOG NO.	5362-1	STARTING SERIALNO.	707D

EXAMPLE:
Component Parts (Small #)
Are Included When Ordering
The Assembly (Large #).

00 0

★ = Part number change from previous service parts list.

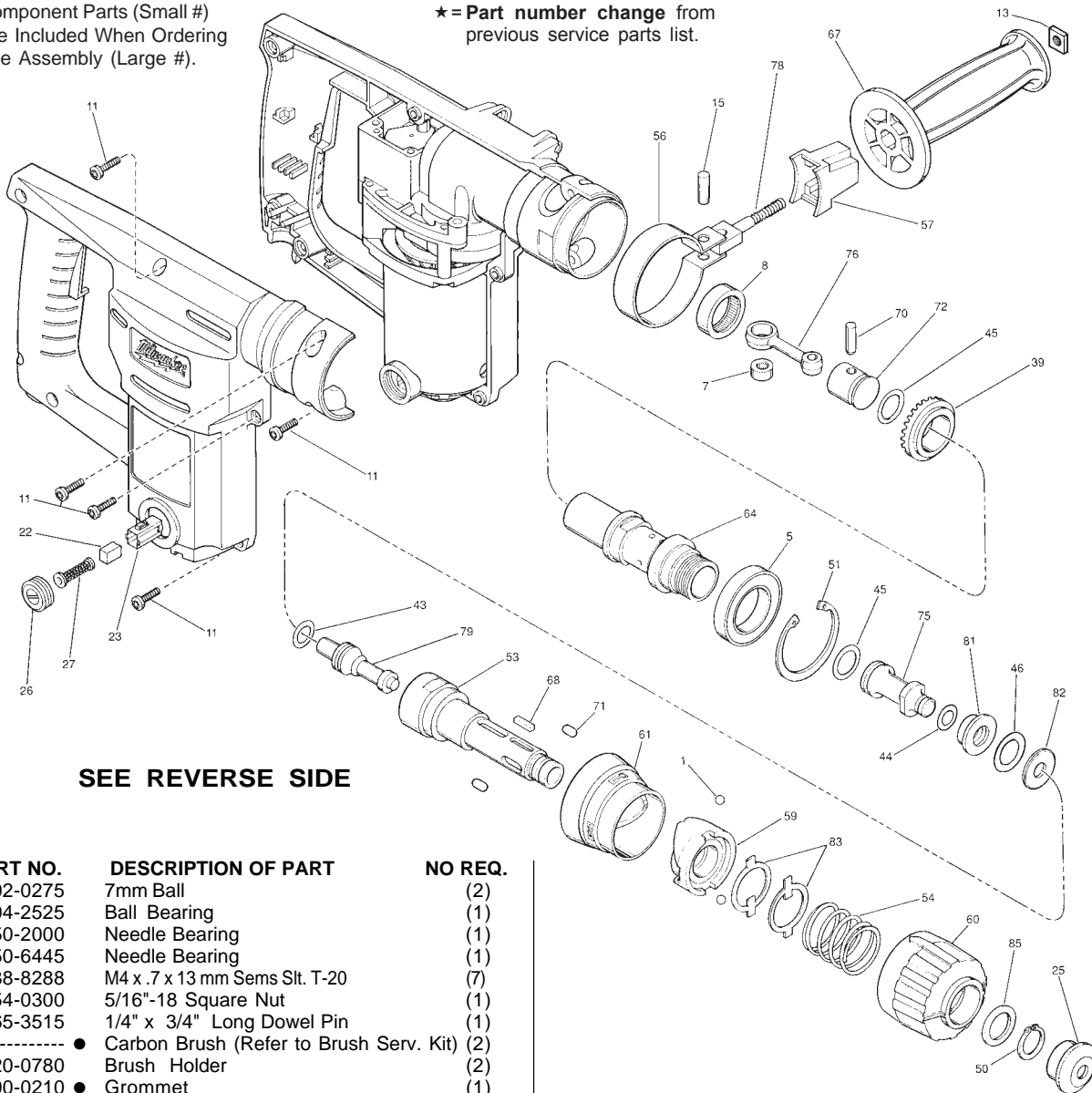

SEE REVERSE SIDE

FIG.	PART NO.	DESCRIPTION OF PART	NO REQ.
1	02-02-0275	7mm Ball	(2)
5	02-04-2525	Ball Bearing	(1)
7	02-50-2000	Needle Bearing	(1)
8	02-50-6445	Needle Bearing	(1)
11	05-88-8288	M4 x .7 x 13 mm Sems Slit. T-20	(7)
13	06-54-0300	5/16"-18 Square Nut	(1)
15	06-65-3515	1/4" x 3/4" Long Dowel Pin	(1)
22	-----	● Carbon Brush (Refer to Brush Serv. Kit)	(2)
23	22-20-0780	Brush Holder	(2)
25	22-90-0210	● Grommet	(1)
26	23-44-0220	Brush Cap Screw	(2)
27	23-52-0255	● Brush Spring (Refer to Brush Serv. Kit)	(2)
39	32-05-2220	Bevel Gear	(1)
43	45-06-0510	● Quad Ring Seal	(1)
44	34-40-1210	● O-Ring	(1)
45	34-40-1215	● O-Ring	(2)
46	34-40-1220	● O-Ring	(1)
50	34-60-2520	● External Retaining Ring	(1)
51	34-80-2980	● Internal Retaining Ring	(1)
53	38-50-5790	Spindle	(1)
54	40-50-1275	Spring	(1)
56	42-16-0120	Side Handle Band	(1)
57	25-10-1501	Side Handle Bracket	(1)
59	42-50-0235	Chuck Cam	(1)
60	42-76-0485	Chuck Collar	(1)
61	42-76-0495	Lockout Collar	(1)
64	42-98-0190	Barrel	(1)
★ 67	43-62-0842	Side Handle	(1)
68	43-96-0135	Key	(1)
70	44-60-0701	Wrist Pin	(1)
71	44-60-1150	● Roller Pin	(2)
72	44-62-0161	Piston	(1)
75	44-82-0135	Ram	(1)

FIG.	PART NO.	DESCRIPTION OF PART	NO.REQ.
76	44-94-0270	Connecting Rod	(1)
78	45-04-0650	Side Handle Screw	(1)
79	45-56-2580	Striker	(1)
81	45-88-1130	Ram Catcher Washer	(1)
82	45-88-1135	Cushion Washer	(1)
83	45-88-5610	Spring Support Washer	(2)
85	45-88-8160	Chuck Collar Washer	(1)

FIG. LUBRICATION
64 3/4 Oz. Type "S2" Grease, No. 49-08-5265, on barrel chamber, between bearing and gear.

FIG. NOTES
46,53, 64,81, 82 Apply two (2) drops of Type AV 271 Red Loctite or equivalent, 180 degrees apart to male threads of barrel. Position ram catcher washer into end of barrel. Place cushion washer and o-ring into spindle. Thread spindle onto barrel. Place spindle nose down and clamp with vice on spindle flats while turning barrel clockwise using flats of barrel. Tighten to 85 ft./lbs.

MILWAUKEE ELECTRIC TOOL CORPORATION
13135 W. LISBON RD., BROOKFIELD, WI 53005
Drwg. 3

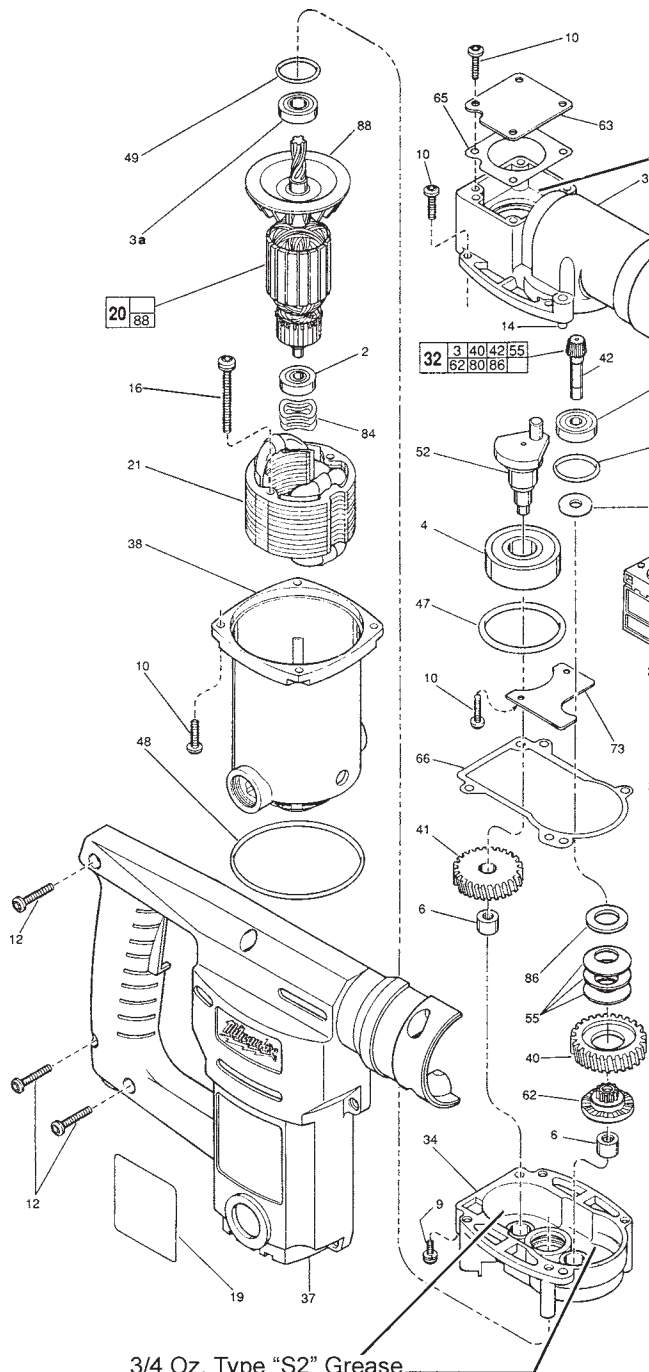

FIG.	PART NO.	DESCRIPTION OF PART	NO. REQ.
2	02-04-0648	Ball Bearing	(1)
3	-----▲	Ball Bearing	(1)
3a	02-04-0851	Ball Bearing	(1)
4	02-04-1710	Ball Bearing	(1)
6	02-50-1620	Needle Bearing	(2)
9	05-88-8300	M4 x .7 x 10mm T-20 Screw	(1)
10	05-88-3641	M4 x .7 x 16mm Taptite T-20	(14)

1/2 Oz. Type "S2" Grease

▲ = Component of 32 Clutch Assembly
 ★ = Part number change from previous service parts list.

3/4 Oz. Type "S2" Grease,
 3/8 Oz. on each side.

22-18-0880 BRUSH SERVICE KIT
THIS KIT INCLUDES:

2	-----	Carbon Brush
2	23-52-0255	Brush Spring

● **14-46-5362 HAMMER SERVICE KIT**
THIS KIT INCLUDES:

1	22-90-0210	Grommet
2	-----	Carbon Brush
2	23-52-0255	Brush Spring
1	34-40-1210	O-Ring
2	34-40-1215	O-Ring
1	34-40-1220	O-Ring
1	34-40-1550	O-Ring
1	34-40-2400	O-Ring
2	34-40-2450	O-Ring
1	34-60-2520	Retaining Ring
1	43-44-0680	Gasket
1	43-44-0905	Gasket
2	44-60-1150	Roller Pin
1	45-06-0510	Quad Ring Seal
1	34-80-2980	Internal Retaining Ring
1	49-08-5265	7 Oz. Type "S2" Grease

FIG.	PART NO.	DESCRIPTION OF PART	NO. REQ.
12	05-88-8296	M4 x .7 x 21mm Sems Slit. T-20	(3)
14	06-65-1310	1/4" x 5/8" Long Dowel Pin	(2)
16	06-82-8989	8-32 x 1-11/16" Pan Hd. T-20	(2)
19	12-20-0390	Service Nameplate Kit	(1)
20	16-10-0090	120 Volt Armature	(1)
21	18-10-0091	120 Volt Field	(1)
24	22-64-3200	Cord Set	(1)
28	23-66-2121	TSC Switch	(1)
32	14-08-0105	Clutch Assembly	(1)
34	28-14-2141	Gear Case	(1)
35	28-14-2160	Crank Case	(1)
36	31-44-1326	Left Handle Half	(1)
37	31-44-1331	Right Handle Half	(1)
38	31-50-0860	Motor Housing	(1)
40	-----▲	Intermediate Clutch Gear	(1)
41	32-40-2020	Intermediate Crank Shaft Gear	(1)
42	-----▲	Bevel Pinion	(1)
47	34-40-1550	● O-Ring	(1)
48	34-40-2400	● O-Ring	(1)
49	34-40-2450	● O-Ring	(2)
52	36-17-0100	Crank Shaft	(1)
55	-----▲	Belleville Washer	(3)
62	-----▲	Clutch Collar	(1)
63	42-92-0335	Crank Case Cover	(1)
65	43-44-0680	● Crank Case Cover Gasket	(1)
66	43-44-0905	● Gear Case Gasket	(1)
69	44-10-0300	Depth Rod Lever	(1)
73	44-66-5761	Bearing Retaining Plate	(1)
74	44-76-0210	Cord Protector	(1)
77	44-94-0280	Depth Rod	(1)
80	-----▲	Washer	(1)
84	45-88-5615	Wave Spring Washer	(3)
86	-----▲	Washer	(1)
88	22-84-0650	Fan	(1)
90	45-06-0530	1" Handle Seal	(1)
91	45-06-0525	1/4" Handle Seal	(1)

FIG. LUBRICATION

- ★ 34 3/4 Oz. Type "S2" Grease, No. 49-08-5265, in gear case.
- ★ 35 1/2 Oz. Type "S2" Grease, No. 49-08-5265, in crank case cavity.