



SERVICE PARTS LIST

BULLETIN NO.

54-24-0351

SPECIFY CATALOG NO. AND SERIAL NO. WHEN ORDERING PARTS		REVISED BULLETIN	DATE
1-1/2" VARIABLE SPEED ROTARY HAMMER		54-24-0350	Feb.'93
CATALOG NO. 5352	STARTING SERIAL NO. 779-6791	WIRING INSTRUCTION 58-01-1230	

EXAMPLE:



Component Parts (Small #) Are Included When Ordering The Assembly (Large #).

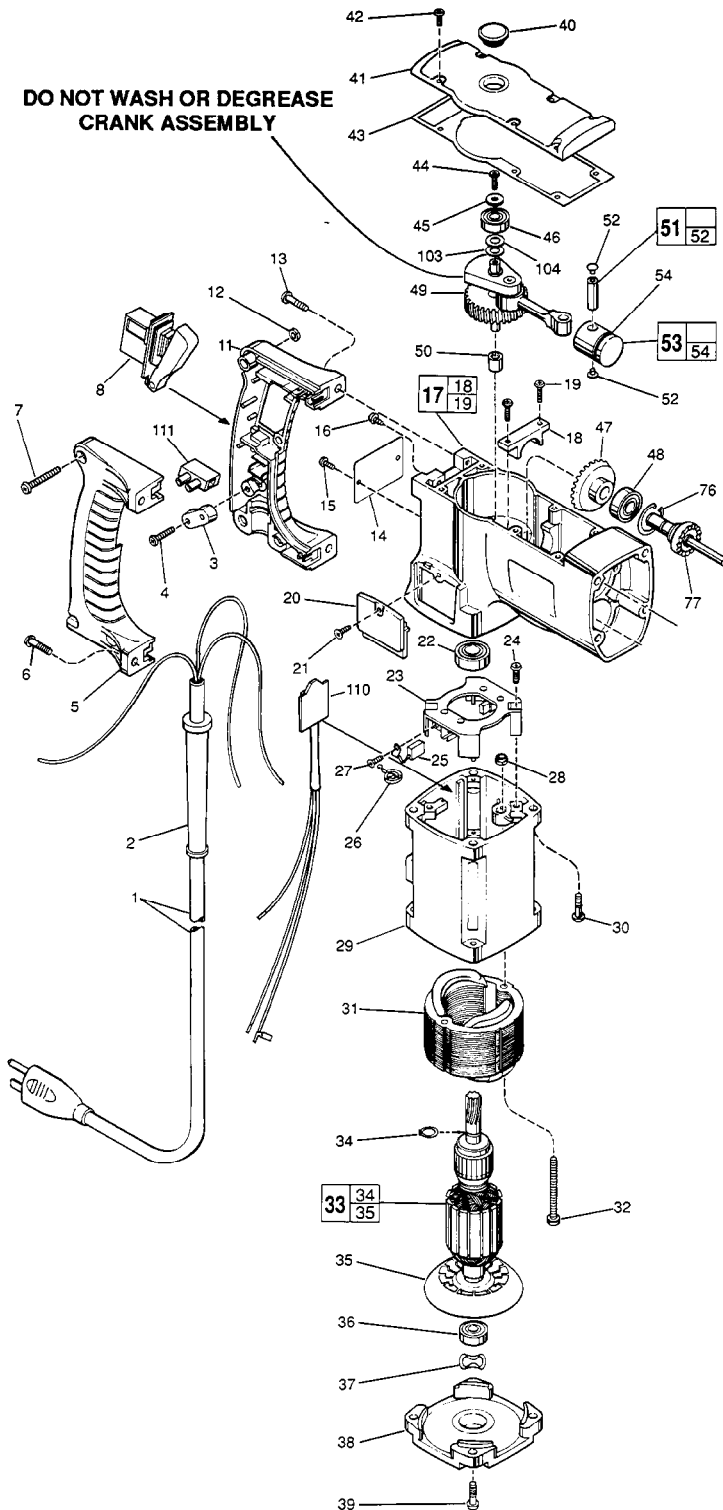

FIG.	PART NO.	DESCRIPTION OF PART	NO. REQ.
1	22-64-0121	Cord Set	(1)
2	44-76-0050	Cord Protector	(1)
3	31-17-0180	Cord Clamp	(1)
4	05-78-0571	M4.55 x 1.59 x 19 Pan Hd. Screw	(2)
5	31-44-1620	Right Handle Half	(1)
6	05-78-0570	M4.55 x 1.59 x 16 Pan Hd. Screw	(2)
7	05-81-0650	M5 x .8 x 25 Pan Hd. Screw	(3)
8	23-66-1930	Switch	(1)
11	31-44-1610	Left Handle Half	(1)
12	05-55-0610	M5 x .8 Hex Nut	(3)
13	05-78-0665	M5 x .8 x 20 Pan Hd. Screw	(2)
14	12-99-0870	Nameplate Blank	(1)
15	06-85-0200	Nameplate Screw	(2)
16	05-78-0415	M4 x .7 x 10 Sems Ground Screw	(1)
★ 17	28-14-2182	Crankcase	(1)
18		Bearing Cap	(1)
19	05-78-0460	M4 x .7 x 16 Pan Hd. Screw	(2)
20	31-15-0250	Brush Cover	(2)
21	05-78-0440	M4 x .7 x 10 Pan Hd. Screw	(2)
22	02-04-1203	Ball Bearing	(1)
23	22-22-1420	Brush Carrier Assembly	(1)
24	05-78-0340	M3.63 x 1.34 x 10 Pan Hd. Screw	(2)
25		Carbon Brush (Refer to Brush Service Kit)	(2)
26	23-52-1550	Brush Spring	(2)
27	05-78-0405	M4 x .7 x 10 Pan Hd. Screw	(2)
28	06-57-3005	10-32 Locking Hex Nut	(2)
29	31-50-0940	Motor Housing	(1)
30	05-74-0515	M5 x .8 x 20 Socket Hd. Sems	(4)
31	18-50-0151	120 Volt Field	(1)
32	06-81-7470	10-32 x 1-7/8 Pan Hd. Sems	(2)
33	16-50-0150	120 Volt Armature	(1)
34	34-60-0950	Retaining Ring	(1)
35	22-84-0710	Fan	(1)
36	02-04-0850	Ball Bearing	(1)
37	45-88-0577	Wave Washer	(1)
38	31-15-0270	Motor Housing Cover	(1)
39	05-78-0570	M4.55 x 1.59 x 16 Pan Hd. Screw	(4)
★ 40	31-12-0220	Cover Cap	(1)
★ 41	28-20-1311	Crank Case Cover	(1)
42	05-78-0460	M4 x .7 x 10 Pan Hd. Screw	(6)
43	43-44-0650	Gasket	(1)
44	05-78-0440	M4 x .7 x 10 Pan Hd. Screw	(1)
45	45-88-0920	Flat Washer - Spring Steel	(1)
46	02-04-0850	Ball Bearing	(1)
47	32-05-1250	Bevel Gear	(1)
48	02-04-1022	Ball Bearing	(1)
49	14-09-0105	Crank Assembly	(1)
50	02-50-1645	Needle Bearing	(1)
51	44-60-0790	Piston Pin Assembly	(1)
52	42-42-0240	Button	(2)
53	14-46-5000	Piston Assembly	(1)
54	34-40-4090	O-Ring	(1)
76	34-80-2006	Internal Retaining Ring	(1)
77	36-14-0700	Clutch Shaft	(1)
★ 103	45-88-0611	.003 Shim Washer	(1)
★ 104	45-88-0612	.008 Shim Washer	(1)
110	14-20-0380	Remote Module Assembly	(1)
111	22-56-0480	Terminal Block	(1)
	10-98-6850	Product Label	(2)

14-46-1192 BRUSH SERVICE KIT

THIS KIT INCLUDES:

- 2 Carbon Brushes
- 1 31-12-0220 Cover Cap
- 1 34-40-4090 O-Ring
- 2 34-40-4090 O-Ring
- 1 34-40-4095 O-Ring
- 1 34-40-4100 O-Ring
- 1 43-44-0650 Gasket
- 1 43-44-0670 Gasket
- 1 44-90-0562 Damping Ring
- 1 45-06-0290 Quad Ring Seal
- 1 49-08-4161 5 Oz. Tube "K" Grease

SEE REVERSE SIDE

MILWAUKEE ELECTRIC TOOL CORPORATION
13135 W. LISBON RD., BROOKFIELD, WI 53005

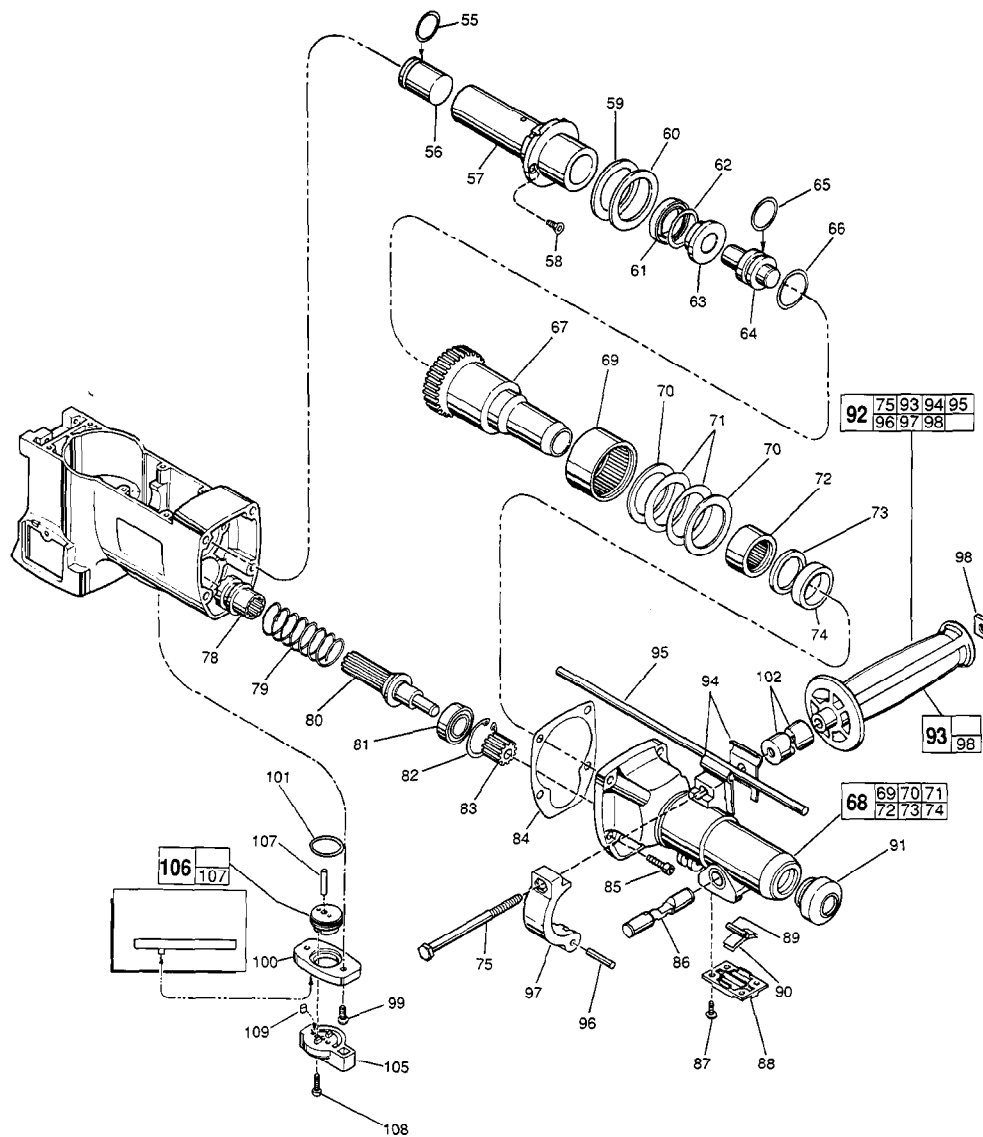

FIG.	PART NO.	DESCRIPTION OF PART	NO. REQ.
55	34-40-4090	O-Ring	(1)
56	44-82-0102	Ram	(1)
57	42-98-0165	Service Barrel Assembly	(1)
58	05-78-0435	M4 x .7 x 13 Flat Hd. Taprite Screw	(2)
59	44-90-0562	Damping Ring - Plastic	(1)
60	45-88-7851	Thrust Washer - Steel	(1)
61	45-88-8015	Cushion Washer	(1)
62	34-40-4085	O-Ring	(1)
63	45-88-8020	Cushion Washer	(1)
64	45-56-2551	Striker	(1)
65	34-40-4095	O-Ring	(1)
66	34-40-4100	O-Ring	(1)
67	38-50-5541	Spindle	(1)
68	28-12-0315	Nose Assembly	(1)
69	02-50-9976	Needle Bearing	(1)
70	45-88-0900	Thrust Washer	(2)
71	40-50-7850	Belleville Spring	(2)
72	02-50-6455	Needle Bearing	(1)
73	45-06-0250	Seal	(1)
74	45-88-5175	Felt Washer	(1)
★ 75	06-75-0354	5/16 -18 x 3.5 Hex Hd. Bolt	(1)
78	36-14-0710	Splined Clutch	(1)
79	40-50-3250	Clutch Spring	(1)
80	14-08-0125	Splined Clutch Assembly	(1)
81	02-04-1510	Ball Bearing	(1)
82	34-80-2355	Internal Retaining Ring	(1)
83	32-60-2160	Pinion	(1)
84	43-44-0670	Gasket	(1)
85	05-74-0615	M6 x 1.0 x 20 Socket Hd. Cap Screw	(4)
86	44-20-0221	Bit Lock	(1)
87	05-78-0440	M4 x .7 x 10 Pan Hd. Screw	(4)
88	28-20-1295	Bit Lock Cover	(1)
89	06-65-1315	Dowel Pin	(1)

FIG.	PART NO.	DESCRIPTION OF PART	NO. REQ.
90	40-50-3275	Bit Retainer Spring	(2)
91	42-76-0380	Dust Collar	(1)
★ 92	43-62-0962	Side Handle Assembly	(1)
93	43-62-0865	Side Handle Assembly	(1)
94	42-68-0390	Depth Gage Clamp	(2)
95	44-94-0165	Depth Gage Rod	(1)
96	06-65-0631	Groove Pin	(1)
★ 97	28-82-0165	Handle Ring Half	(2)
★ 98	06-54-0300	Square Nut	(1)
99	05-78-0440	M4 x .7 x 10 Pan Hd. Screw	(2)
★ 100	44-86-0530	Shift Lever Retainer	(1)
101	34-40-4160	O-Ring	(1)
★ 102	45-36-1180	Spacer	(1)
105	44-10-0150	Shift Lever	(1)
★ 106	14-14-0152	Shift Disc Assembly	(1)
107		Dowel Pin	(1)
108	05-78-0300	M3 x .5 x 16MM Socket Hd. Screw	(2)
★ 109	45-30-0060	Retaining Slug	(1)

FIG. 19,58, NOTES:
 87 Apply Type 242 Blue Loctite. Torque To 30-35 In.-Lb.
 50 Press Flush To Bottom Of Bore (1.845 Deep).
 85 Apply Type 242 Blue Loctite and Torque To 130-140 In.-Lb.

FIG. LUBRICATION
 49 2-1/2 Oz. Type "K" Grease, No. 49-08-4161.
 80 1-1/2 Oz. Type "K" Grease, No. 49-08-4161.
 83 1 Oz. Type "K" Grease, No. 49-08-4161.
 Grease All Rubber Parts When Assembling .