



SERVICE PARTS LIST

SPECIFY CATALOG NO. AND SERIAL NO. WHEN ORDERING PARTS		REVISED BULLETIN	DATE
1-1/2" (40mm) ROTARY HAMMER		55-24-3811	Aug. 2006
CAT. NO. 5315-51 (PHE 40SQ)	STARTING SERIAL NO. 338C	WIRING INSTRUCTION	
PRODUCT NUMBER 4000 4000 47		58-03-1851	
		See wiring instruction for terminals, connectors and end wire preparation	

EXAMPLE:
 Component Parts (Small #) Are Included
 When Ordering The Assembly (Large #).

▲ SEE BACK PAGE OF THIS BULLETIN FOR ADDITIONAL LUBRICATION AND SERVICE NOTES

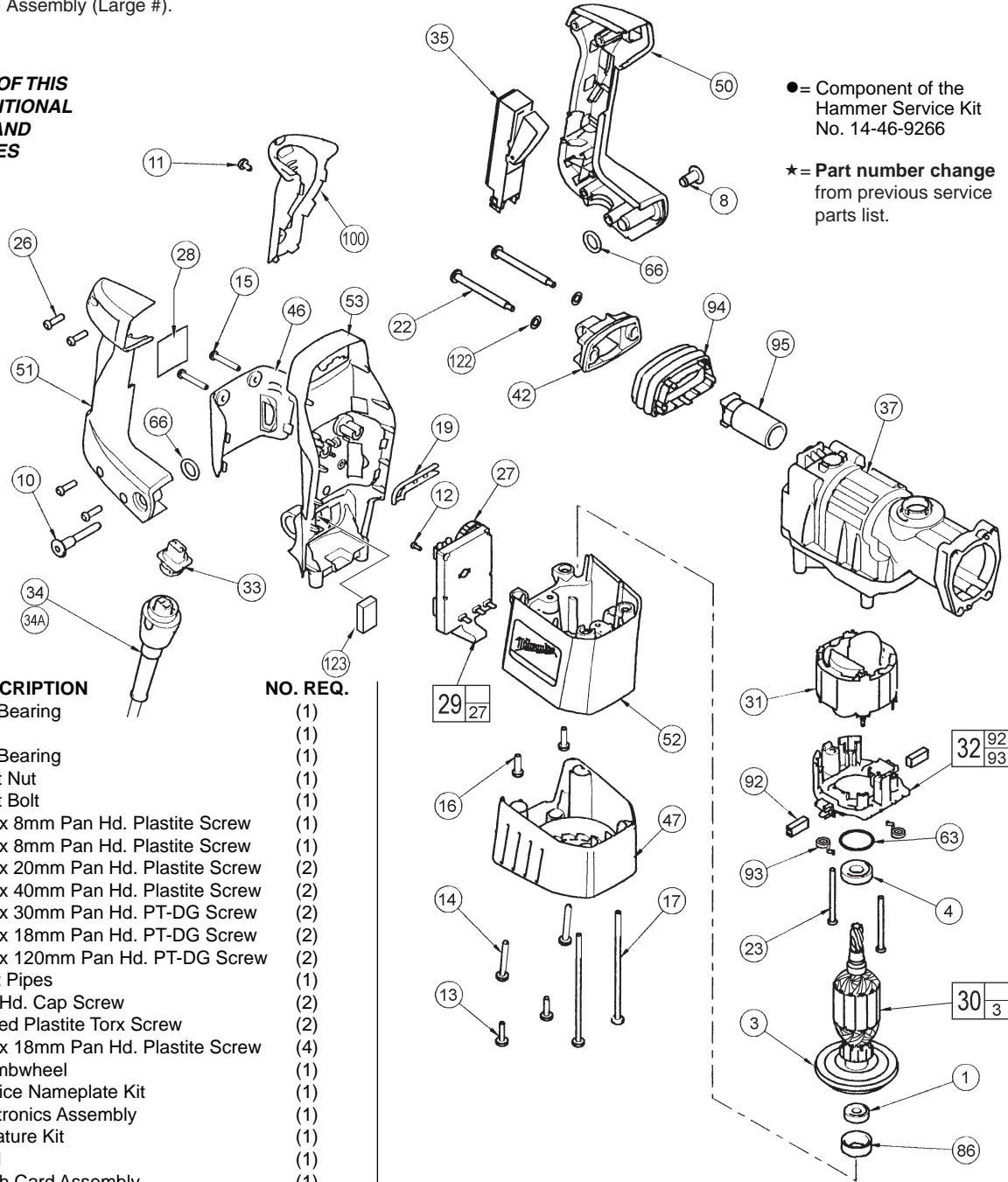

● = Component of the Hammer Service Kit No. 14-46-9266

★ = Part number change from previous service parts list.

FIG.	PART NO.	DESCRIPTION	NO. REQ.
	1	Ball Bearing	(1)
	3	Fan	(1)
★	4	Ball Bearing	(1)
	8	Pivot Nut	(1)
	10	Pivot Bolt	(1)
	11	K50 x 8mm Pan Hd. Plastite Screw	(1)
	12	K35 x 8mm Pan Hd. Plastite Screw	(1)
	13	K60 x 20mm Pan Hd. Plastite Screw	(2)
	14	K60 x 40mm Pan Hd. Plastite Screw	(2)
	15	K50 x 30mm Pan Hd. PT-DG Screw	(2)
	16	K60 x 18mm Pan Hd. PT-DG Screw	(2)
	17	K60 x 120mm Pan Hd. PT-DG Screw	(2)
	19	Light Pipes	(1)
	22	Pan Hd. Cap Screw	(2)
	23	Slotted Plastite Torx Screw	(2)
	26	K50 x 18mm Pan Hd. Plastite Screw	(4)
	27	Thumbwheel	(1)
	28	Service Nameplate Kit	(1)
★	29	Electronics Assembly	(1)
★	30	Armature Kit	(1)
	31	Field	(1)
★	32	Brush Card Assembly	(1)
	33	Blade Housing Assembly	(1)
	34	Quik-Lok Cord Set	(1)
	34A	Quik-Lok Cord Set (Australia)	(1)
	35	Switch	(1)
	37	Crankcase Assembly	(1)
	42	Upper Handle Mount	(1)
	46	Module Cover	(1)
	47	Motor Cover	(1)
	50	Left Handle Half	(1)
	51	Right Handle Half	(1)
	52	Motor Housing	(1)
	53	Rear Shroud	(1)
★	63	O-Ring	(1)
	66	O-Ring	(2)
	86	● Bearing Cup	(1)

FIG.	PART NO.	DESCRIPTION OF PART	NO. REQ.
★	92	● Carbon Brush Kit (Includes 2 Brushes)	(1)
	93	Brush Spring	(2)
	94	Bellows	(1)
	95	Isolation Module Assembly	(1)
	100	Cushion Grip	(1)
	122	Rubber Washer	(2)
	123	Handle Seal	(1)

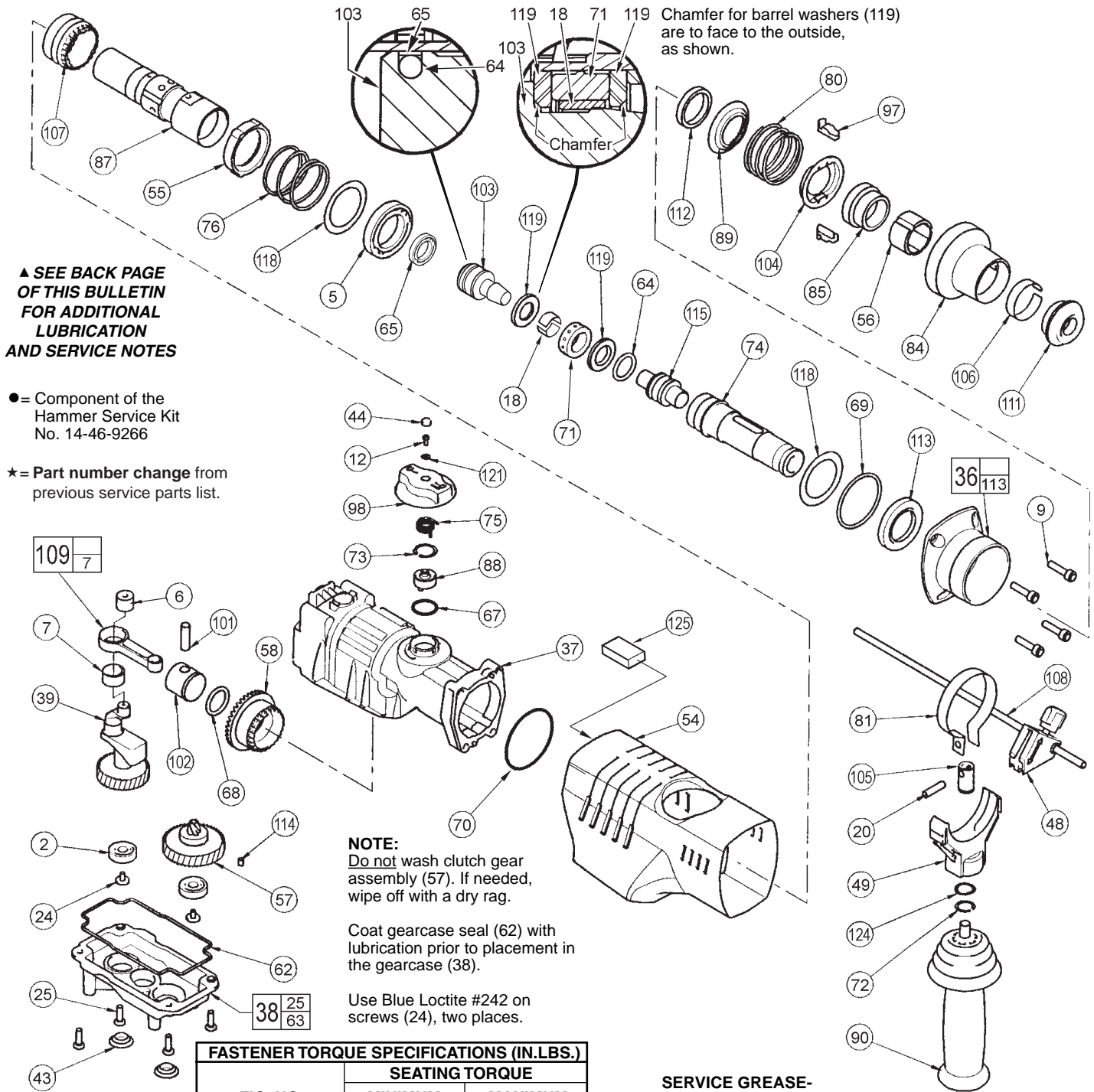

▲ SEE BACK PAGE OF THIS BULLETIN FOR ADDITIONAL LUBRICATION AND SERVICE NOTES

FASTENER TORQUE SPECIFICATIONS (IN.LBS.)		
FIG. NO.	SEATING TORQUE	
	MINIMUM	MAXIMUM
9	120	140
10	20	25
11	3	6
12	4	8
13	20	25
14	20	25
15	15	20
16	50	55
17	30	35
22	30	35
23	12	17
24	20	25
25	45	50
26	15	20
74	130 FT. LBS.	200 FT. LBS.
87	130 FT. LBS.	200 FT. LBS.
Switch Screws	4	6

- SERVICE GREASE-**
● "S2" Grease, No. 49-08-5265 7 oz. tube
- **14-46-9266 HAMMER SERVICE KIT**
THIS KIT CONTAINS:
- | | | |
|---|------------|------------------------|
| 2 | 31-12-0040 | Cap Plug |
| 1 | 34-40-0240 | Gearcase Seal |
| 2 | 34-40-4350 | O-Ring |
| 1 | 34-40-4475 | Cap Seal |
| 1 | 34-40-4215 | O-Ring |
| 1 | 34-40-4510 | O-Ring |
| 1 | 34-40-4530 | O-Ring |
| 1 | 34-40-4570 | Damping Washer |
| 1 | 42-96-0125 | Bearing Cup |
| 2 | 45-22-0680 | Split Sleeve |
| 1 | 22-18-1353 | Carbon Brush Kit |
| 1 | 49-08-5265 | "S2" Grease, 7oz. Tube |
- **22-18-1353 CARBON BRUSH SERVICE KIT**
THIS KIT CONTAINS:
- | | | |
|---|-------|--------------|
| 2 | ----- | Carbon Brush |
|---|-------|--------------|

FIG.	PART NO.	DESCRIPTION OF PART	NO. REQ.
2	02-04-0911	Ball Bearing	(2)
5	02-08-0640	Ball Bearing	(1)
★ 6	02-50-2755	Needle Bearing	(1)
7	02-50-4020	Needle Bearing	(1)
9	05-74-0625	M6 Socket Head Cap Screw	(4)
12	05-88-5910	K35 x 8mm Pan Hd. Plastite Screw	(1)
18	45-22-0680	● Split Sleeve	(2)
20	06-65-1660	Dowel Pin	(1)
24	06-82-8842	Slotted Taptite Torx Screw	(2)
25	05-88-9910	K50 x 22mm PT-DG Screw	(4)
36	14-52-0030	SDS-Max Nose Service Assembly	(1)
37	28-14-2541	Crankcase Assembly	(1)
38	14-46-2565	Gearcase Service Kit	(1)
★ 39	14-09-0161	Crankshaft Assembly	(1)
43	31-12-0040	● 5/8 Cap Plug	(2)
44	31-12-0185	Screw Cap	(1)
48	14-34-0551	Depth Rod Mount Assembly	(1)
49	31-44-2000	Side Handle Housing	(1)
54	31-55-0301	Main Shroud	(1)
55	31-58-0150	Locking Ring	(1)
56	31-86-0100	Spacer	(1)
★ 57	14-08-0211	Clutch Gear Assembly	(1)
58	32-30-0060	Drive Gear	(1)
62	34-40-0240	● Gearcase Seal	(1)
64	34-40-4350	● O-Ring	(2)
65	34-40-4475	● Capseal	(1)
67	34-40-4500	O-Ring	(1)
68	34-40-4510	● O-Ring	(1)
69	34-40-4520	O-Ring	(1)
70	34-40-4530	● O-Ring	(1)
71	34-40-4570	● Damping Washer	(1)
72	34-60-2580	External Retaining Ring	(1)
73	34-80-5010	Retaining Ring	(1)
74	38-50-6250	Spindle	(1)
75	40-50-0370	Shift Spring	(1)
76	40-50-0380	Compression Spring	(1)
80	40-50-8870	Key Spring	(1)
81	42-16-0125	Side Handle Band	(1)
84	42-76-0710	Chuck Collar	(1)
85	42-76-0715	Collar	(1)
87	42-98-0260	Barrel	(1)
88	14-14-0170	Shift Disk Assembly	(1)
89	43-34-0440	Spring Flange	(1)
90	14-34-0516	Side Handle Assembly	(1)
97	43-96-0220	Keys	(2)
98	14-34-0180	Shift Knob Assembly	(1)
101	44-60-1710	Wrist Pin	(1)
102	44-62-0230	Piston	(1)
103	44-82-0220	Ram	(1)
104	44-86-0610	Key Retaining Ring	(1)
105	44-86-0620	Band Retainer	(1)
106	44-90-0005	Seal Retaining Ring	(1)
107	44-90-0175	Shift Ring	(1)
108	44-94-0165	Depth Gauge Rod	(1)
109	44-94-0395	Connecting Rod Assembly	(1)
111	45-06-0555	Dust Seal	(1)
112	45-06-0685	Felt Seal	(1)
113	-----	Spindle Seal	(1)
114	45-30-0060	Retaining Slug	(1)
115	45-56-2640	SDS-Max Striker	(1)
118	45-88-1565	Washer	(2)
119	45-88-4005	Barrel Washer	(2)
121	45-88-7170	Washer	(1)
124	45-88-8730	Wave Washer	(1)
★ 125	44-52-0041	Breather Pad	(1)

NOTE: Check the clutch torque. Clutch must slip at 40 to 50 ft.lbs. at the spindle, checked clockwise as viewed from the front of the tool.

▲ SEE BACK PAGE OF THIS BULLETIN FOR ADDITIONAL LUBRICATION AND SERVICE NOTES

Press Needle Bearing (7) in Connecting Rod (109) so that the same amount sticks out on both sides of the Rod.

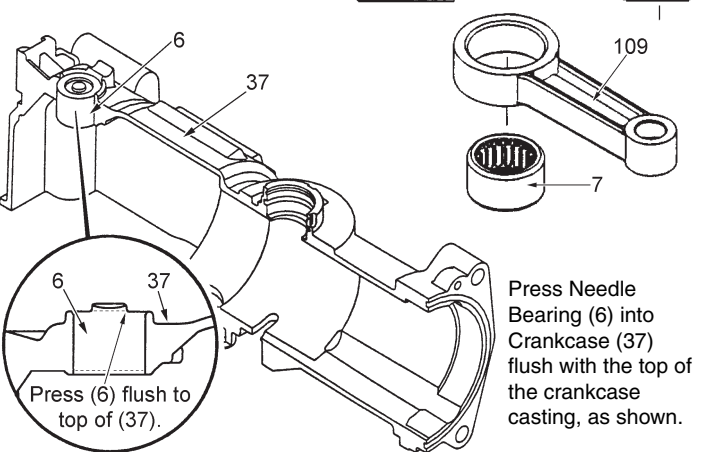

LUBRICATION NOTES: (TYPE "S2" GREASE, NO. 49-08-5265)

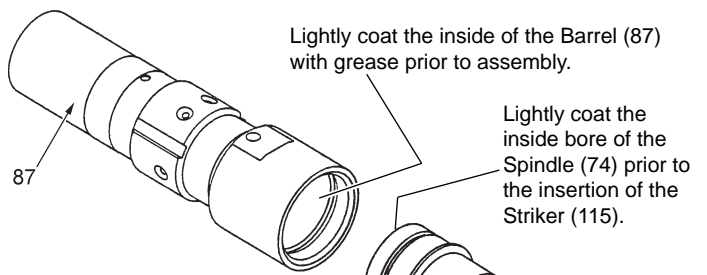
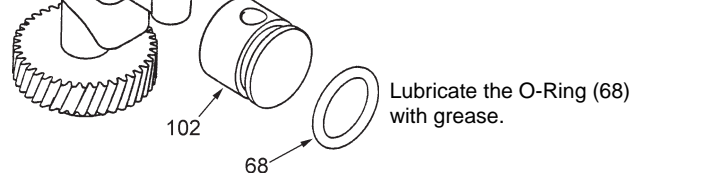
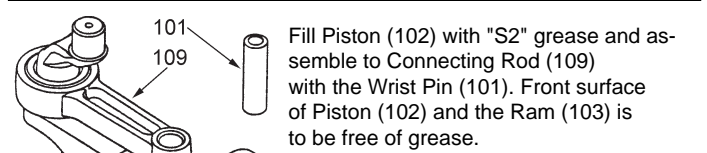

See back page for special service tool and torque values

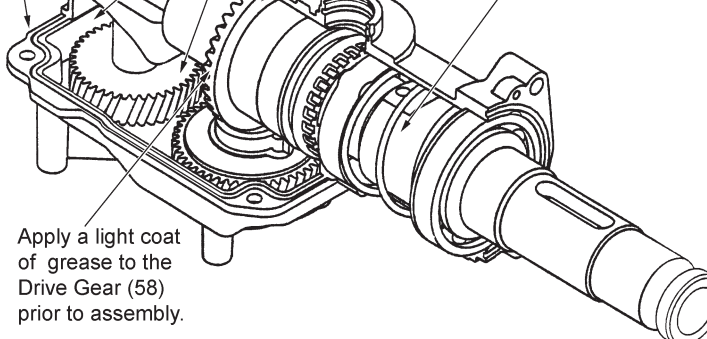
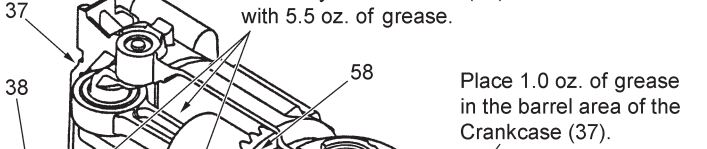
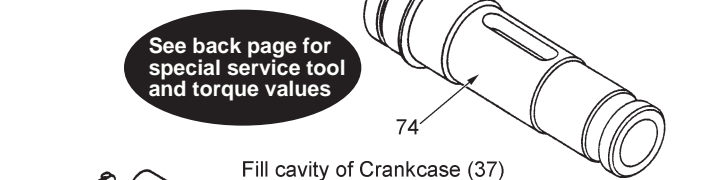

Prior to assembly, apply a light coat of grease to the Gearcase Seal (62) and O-Rings (63, 64, 67, 68 and 70).

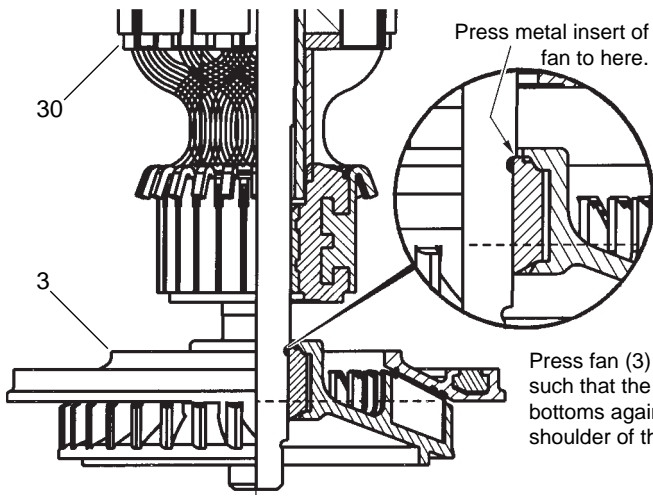

Press metal insert of fan to here.

Press fan (3) onto armature (30) such that the metal insert of the fan bottoms against the fan journal shoulder of the armature shaft.

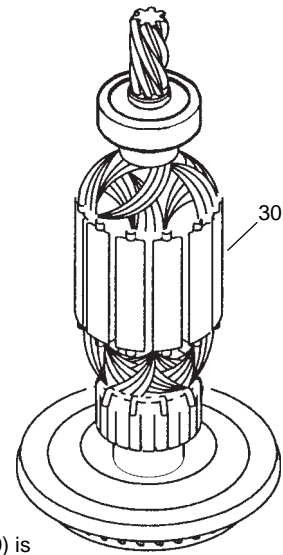

After the armature assembly (30) is installed into the tool, the bearing cup (86) is to be placed on the rear armature bearing (1), (already pressed onto the armature shaft), prior to assembling the motor cover (47) to the tool.

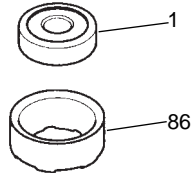

NOTE: Do not dislodge the bearing cup from the bearing during assembly.

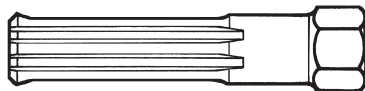

61-10-2060 SDS-MAX Shank

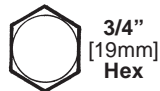

3/4" [19mm] Hex

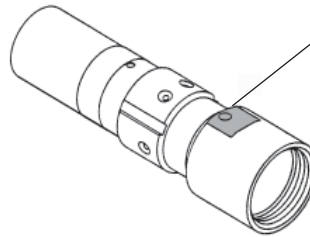

Barrel

when tightened in a vise, **extra care** should be taken not allowing the barrel to turn and mar or burr it's finished cylindrical surface.

no loctite® is required on threads of spindle or barrel.

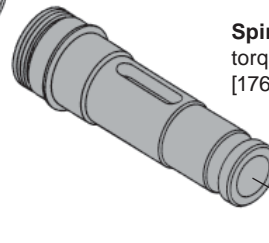

Spindle

torque to 130-160 ft-lbs. [176-217 Newton-meters]

BARREL / SDS MAX SPINDLE SERVICING-

To aid in the servicing of the Barrel and Spindle of the 5315-51 SDS-MAX Rotary Hammer, a Service Tool No. 61-10-2060 has been developed [see illustrations].

- clamp the flats of the Barrel in a vise.
- use a 3/4" [19mm] socket on the hex of Service Tool to either remove [turning counter-clockwise] or install [turning clockwise] the Spindle.

SERVICE NOTE:
SLIP CLUTCH VALUES

When servicing this SDS-MAX Rotary Hammer, the static torque required to slip the clutch mechanism should be checked. It must not exceed the maximum value shown below:

- block armature from rotating.
- using service tool and ft.-lb [newton-meter] torque wrench with 3/4" [19mm] socket, check the static torque required to slip the Spindle / Clutch Mechanism of the Rotary Hammer.
- **the torque for the 5315-51 should be 40-50 ft-lb. [52-68 Nm].**