



SERVICE PARTS LIST

SPECIFY CATALOG NO. AND SERIAL NO. WHEN ORDERING PARTS		REVISED BULLETIN 55-24-0527	DATE Mar. 2003
1-1/2" SDS THUNDERMAX™ ROTARY HAMMER			
CATALOG NO. 5313-51	STARTING SERIAL NO.	885D	WIRING INSTRUCTION 58-03-1790

★=Part number change from previous service parts list.

00/0

EXAMPLE:
 Component Parts (Small #) Are Included When Ordering The Assembly (Large #).

FIG.	PART NO.	DESCRIPTION OF PART	NO. REQ.
41	23-52-1550	Brush Spring	(2)
★42	23-66-2160	Speed Control Switch	(1)
47	28-90-0280	Upper Handle Mount	(1)

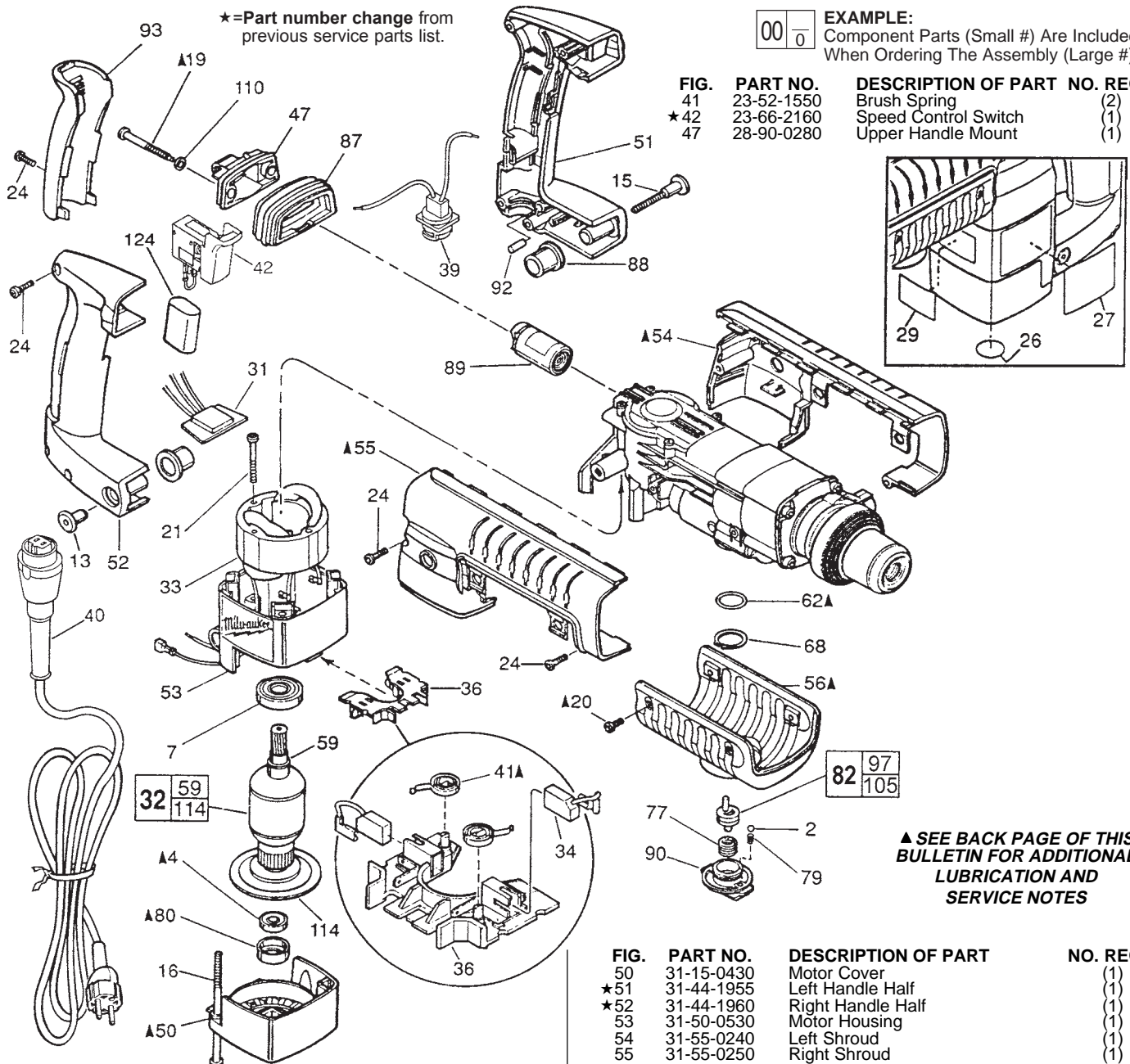

▲ SEE BACK PAGE OF THIS BULLETIN FOR ADDITIONAL LUBRICATION AND SERVICE NOTES

FIG.	PART NO.	DESCRIPTION OF PART	NO. REQ.
2	02-02-1300	5mm Steel Ball	(2)
4	02-04-0847	Ball Bearing	(1)
7	02-04-1518	Ball Bearing	(1)
13	05-59-0100	Pivot Nut	(1)
15	05-77-0100	Pivot Bolt	(1)
16	05-81-0920	M6 x 1.0 x 120 Pan Hd. Slit. Tapt. T-27	(4)
19	06-81-1805	Special Screw	(2)
20	06-82-7252	8-32 x 3/8" Pan Hd. Slit. Tapt. T-20	(2)
21	06-82-7425	8-16 x 2" Pan Hd. Slit. Plast. T-20	(4)
24	06-95-6290	M5 x 2.24 x 18 Pan Hd. Slit. PT T-20	(7)
26	10-75-2760	Milwaukee Label	(1)
27	10-98-5313	Product Label	(1)
29	12-20-3310	Service Nameplate Kit	(1)
★31	14-20-0736	Remote Trigger Speed Control	(1)
32	16-54-1261	230 Volt Armature	(1)
33	18-54-0260	230 Volt Field	(1)
34	22-18-0875	230 V Carbon Brush (2) Kit	(1)
36	22-22-1480	Brush Carrier Assembly	(1)
39	22-56-0693	Blade Housing Assembly	(1)
40	48-76-5012	Quik-Lok Cord	(1)

FIG.	PART NO.	DESCRIPTION OF PART	NO. REQ.
50	31-15-0430	Motor Cover	(1)
★51	31-44-1955	Left Handle Half	(1)
★52	31-44-1960	Right Handle Half	(1)
53	31-50-0530	Motor Housing	(1)
54	31-55-0240	Left Shroud	(1)
55	31-55-0250	Right Shroud	(1)
56	31-55-0230	Belly Shroud	(1)
59	34-60-3620	Retaining Ring	(1)
62	34-40-4160	O-Ring	(1)
68	34-60-3630	Retaining Ring	(1)
77	40-50-8585	Torsion Spring	(1)
79	40-50-8690	Compression Spring	(2)
80	42-96-0130	Bearing Cup	(1)
★82	14-46-0112	Clutch Service Kit	(1)
87	43-87-0030	Isolation Bellows	(1)
88	43-87-0040	Pivot Isolator	(2)
89	43-87-0060	Isolation Module Assembly	(1)
90	43-98-0470	Rotostop Knob	(1)
92	14-46-1001	Foam Slug Kit (Bag of 10)	(1)
93	44-52-0580	Handle Cushion	(1)
110	45-88-8555	Rubber Washer	(2)
114	22-84-0870	Fan	(1)
124	22-33-0510	Suppressor	(1)

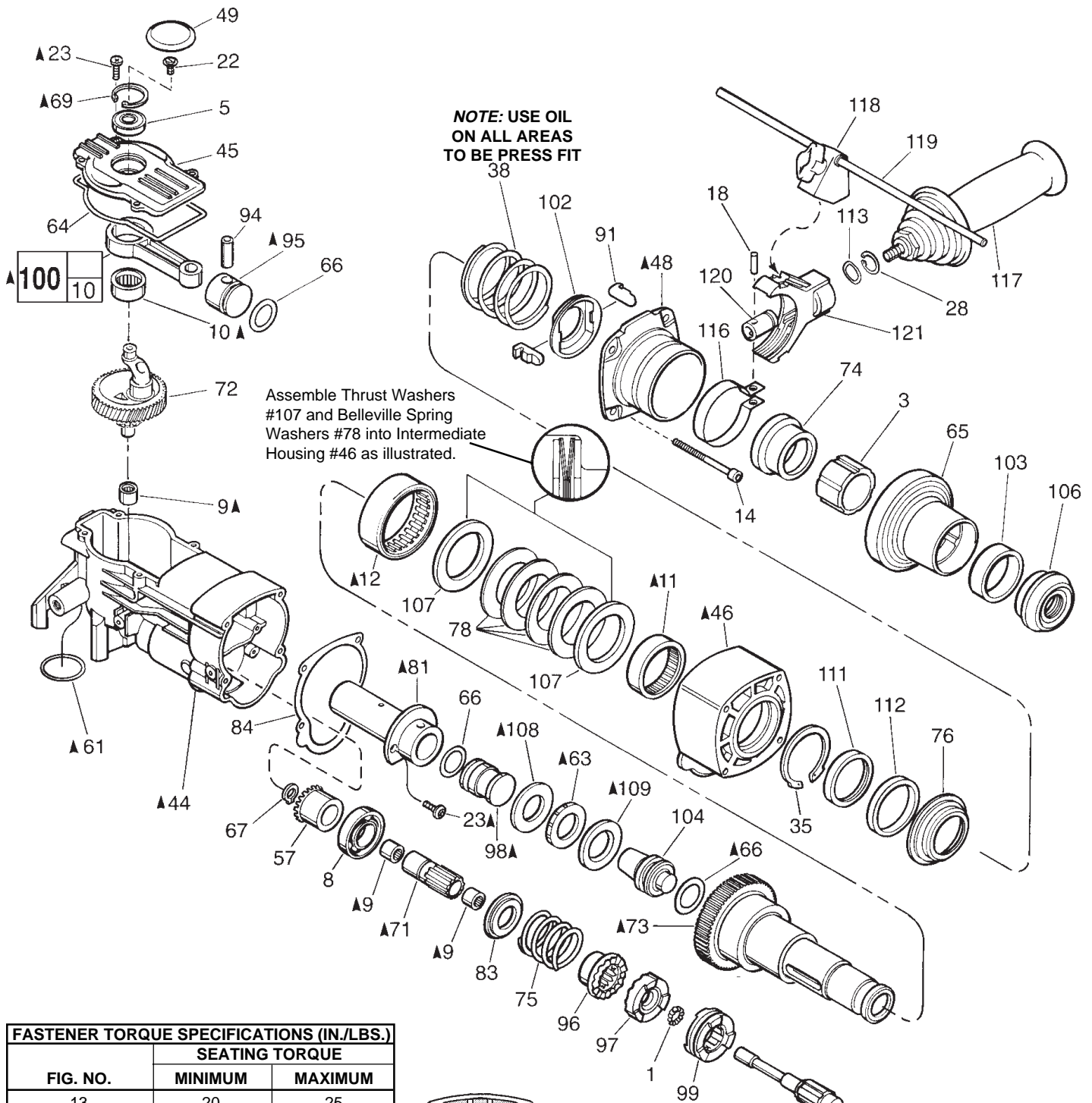

FASTENER TORQUE SPECIFICATIONS (IN./LBS.)		
FIG. NO.	SEATING TORQUE	
	MINIMUM	MAXIMUM
13	20	25
14	120	140
15	20	25
16	30	35
19	30	35
20	25	30
21	20	25
22	20	25
23	30	35
24	15	20
25	35	45

22-18-0875 CARBON BRUSH SERVICE KIT

THIS KIT CONTAINS:

- 2 ----- Carbon Brush

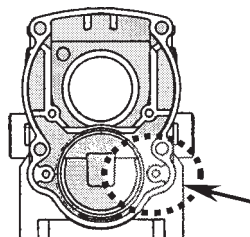

For tools with serial numbers above 885D10020XXXX - production Crankcase (fig. 44) has machined (milled surface) clutch screw bosses which eliminates the need for Clutch Tube (fig. 105).

● **14-46-9075 1-1/2" HAMMER SERVICE KIT**

THIS KIT CONTAINS:

- 1 31-12-0270 Cap-Cover
- 1 34-40-4310 Rubber Damping Washer
- 1 34-40-4320 Seal-Cover
- 3 34-40-4350 O-Ring Piston, Ram, Striker
- 1 42-96-0130 Bearing Cup
- 1 43-44-0970 Gasket
- 1 45-06-0680 Felt Seal
- 1 49-08-5265 7 Oz. Tube "S2" Grease

▲ SEE BACK PAGE OF THIS BULLETIN FOR ADDITIONAL LUBRICATION AND SERVICE NOTES

FIG.	PART NO.	DESCRIPTION OF PART	NO. REQ.
1	02-02-0120	1/8" Steel Ball	(12)
3	31-86-0100	Spacer	(1)
5	02-04-0911	Ball Bearing	(1)
6	02-04-1510	Ball Bearing	(1)
8	02-04-2000	Ball Bearing	(1)
9	02-50-2470	Needle Bearing	(3)
10	02-50-4020	Needle Bearing	(1)
11	02-50-9000	Needle Bearing	(1)
12	02-50-9985	Needle Bearing	(1)
14	05-81-0830	M6 x 1.0 x 70 Pan Hd. Screw T-27	(4)
17	06-65-3750	Drive Pin	(4)
18	06-65-1660	Dowel Pin	(1)
22	06-82-8842	8-32 x 3/8" Pan Hd. Slit. Taptite T-20	(1)
23	06-95-6280	M4 x 0.7 x 14 Pan Hd. Slit. Taptite T-20	(8)
25	34-40-4430	O-Ring	(1)
28	34-60-2580	External Retaining Ring	(1)
35	34-80-5100	Internal Retaining Ring	(1)
★37	-----	Spindle Extension (◆=See Note Below)	(1)
38	40-50-8870	Compression Spring	(1)
43	30-89-0010	Bearing Retainer	(1)
44	28-14-2295	Crankcase	(1)
45	28-20-1325	Crankcase Cover	(1)
46	28-50-8680	Intermediate Housing	(1)
48	28-12-0110	Nose Flange	(1)
49	31-12-0270●	Cap-Cover	(1)
57	32-05-2250	Bevel Gear	(1)
58	32-60-2590	Clutch Pinion	(1)
61	34-40-1375	O-Ring	(1)
63	34-40-4310●	Rubber Damping Washer	(1)
64	34-40-4320●	Seal-Cover	(1)
65	42-76-0710	Chuck Collar	(1)
66	34-40-4350●	O-Ring	(3)
67	34-60-0700	Retaining Ring	(1)
69	34-80-5090	Retaining Ring-Beveled	(1)
70	36-14-0760	Clutch Shaft	(1)
71	36-14-0770	Hollow Clutch Shaft	(1)
72	14-09-0140	Crankshaft Assembly	(1)
73	38-50-6085	Spindle	(1)
74	42-76-0715	Collar	(1)
75	40-50-8575	Compression Spring	(1)
★76	43-34-0765	Spring Flange	(1)
78	40-50-8590	Belleville Spring	(4)
81	42-98-0200	Barrel	(1)
83	43-34-0740	Spring Flange	(1)
84	43-44-0970●	Gasket	(1)
91	43-96-0220	Key	(2)
94	44-60-1400	Wrist Pin	(1)
95	44-62-0210	Piston	(1)
96	44-66-6030	Splined Clutch Plate	(1)
97	44-66-6045	Fixed Clutch Plate	(1)
98	44-82-0170	Ram	(1)
99	44-90-4400	Shift Ring	(1)
100	44-94-0395	Connecting Rod Assembly	(1)
102	44-86-0610	Key Retaining Ring	(1)
103	44-90-0005	Seal Retaining Ring	(1)
104	45-56-2620	Striker	(1)
105	45-76-0490	Clutch Tube	(1)
106	45-06-0555	Dust Seal	(1)
107	45-88-8520	Thrust Washer	(2)
108	45-88-8530	Barrel Thrust Washer	(1)
109	45-88-8535	Striker Cushion Washer	(1)
111	45-06-0670	Oil Seal	(1)
112	45-06-0680●	Felt Seal	(1)
113	45-88-8730	Wave Washer	(1)
116	42-16-0125	Side Handle Band	(1)
★117	14-34-0516	Side Handle Assembly	(1)
★118	14-34-0551	Depth Rod Mount Assembly	(1)
119	44-94-0165	Depth Gauge Rod	(1)
120	44-86-0620	Band Retainer	(1)
121	31-44-2000	Side Handle Housing	(1)

NOTE: Check the clutch torque. Clutch must slip at 30 to 38 ft.-lbs. at the spindle, checked clockwise as viewed from the front of the tool.

▲ SEE BACK PAGE OF THIS BULLETIN FOR ADDITIONAL LUBRICATION AND SERVICE NOTES

◆= When replacing item 37 (spindle extension), No. 38-50-6150 must be ordered. When using the replacement spindle No. 38-50-6150, discard items 17, 25, 37 and 73.

LUBRICATION NOTES: (TYPE "S2" GREASE, NO. 49-08-5265)

Fill Piston #95 with grease and assemble to Connecting Rod #100 with Wrist Pin #94. Front surface of Piston to be free of grease.

Lubricate O-Ring #66 with grease.

Place 1.5 oz. grease here.

Place a total of 1.0 oz. grease in the barrel cavity in the crankcase #44. Place .5 oz. in each corner in barrel chamber.

Place 1.5 oz. grease in bottom of crankcase prior to installing crankshaft assembly.

FRONT OF CRANKCASE

Apply grease to lobed surface #97.

Apply grease to spline surface #71.

Apply grease to lobed surface #96.

Apply grease to radius and spline surface #70.

Apply .5 oz. grease on clutch assembly, filling the spring coils.

Lubricate O-Ring #66 with grease. Install O-Ring onto Ram #98. Assemble Ram into Barrel #81, O-Ring end first. Set end of Ram flush with end of Barrel. Do not push Ram deep into Barrel.

Place .5 oz. grease in lower clutch pinion cavity.

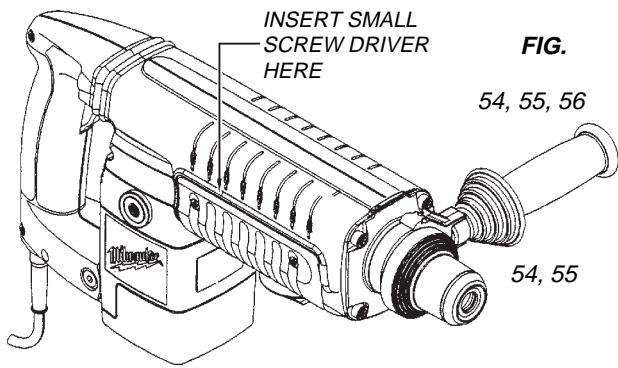

FIG. ▲ NOTES

TO REMOVE BELLY SHROUD #56 FROM TOOL, INSERT SMALL SCREW DRIVER INTO GROOVE BETWEEN BELLY AND SIDE SHROUDS #54 AND #55, ABOUT 1/3 OF THE WAY FROM THE MOTOR END, AS SHOWN. PRY OUT AND DOWN ON BOTH SIDES OF THE TOOL.

TO INSTALL THE SIDE SHROUDS #54 AND #55, THE TOP HINGE OF THE SHROUDS MUST BE COMPLETELY INTERLOCKED, THEN THE BACK SIDE ROTATED CLOSED AROUND THE TOOL.

73 LUBRICATE ALL BORES IN SPINDLE #73 WITH A MEDIUM COATING OF GREASE.

63, 108, 109 LUBRICATE RUBBER DAMPING WASHER #63, BARREL THRUST WASHER #108 AND STRIKER CUSHION WASHER #109 WITH A MEDIUM COATING OF GREASE BEFORE ASSEMBLY.

10, 100 PRESS NEEDLE BEARING #10 IN ROD #100 SO THAT THE SAME AMOUNT STICKS OUT ON BOTH SIDES OF THE ROD, AS SHOWN.

9, 71 PRESS (2) NEEDLE BEARINGS #9 INTO HOLLOW CLUTCH SHAFT #71, FLUSH WITH THE ENDS OF THE SHAFT.

58, 70 PRESS CLUTCH PINION #58 FLUSH WITH THE END OF THE CLUTCH SHAFT #70.

11, 12, 46 PRESS NEEDLE BEARING #11 FLUSH TO THE INSIDE SURFACE OF THE INTERMEDIATE HOUSING #46, AGAINST THE SNAP RING. PRESS NEEDLE BEARING #12 FLUSH TO THE OUTSIDE MACHINED SURFACE OF THE INTERMEDIATE HOUSING.

9, 44 PRESS NEEDLE BEARING #9 INTO CRANKCASE #44, FLUSH WITH TOP OF BORE, AS SHOWN.

81 LIGHTLY GREASE INSIDE OF BARREL #81 BEFORE ASSEMBLY.

14, 19, 20, 23 FASTENERS #14, #19, #20 AND #23 ARE TO BE RE-ASSEMBLED USING BLUE LOCTITE.

61, 62, 66 LUBRICATE O-RINGS #61, #62 AND #66 WITH GREASE.

69 INSTALL BEVEL SNAP RING #69 WITH BEVEL SIDE UP.

4, 50, 80 PLACE BEARING CUP #80 ON SMALL ARMATURE BEARING #4 BEFORE INSTALLING MOTOR COVER #50.

41 BRUSH SPRINGS #41 ARE TO BE WOUND 1/2 TURN TO ENGAGE BRUSHES.

4 RUBBER SEAL SIDE OF BALL BEARING #4 TO FACE FAN.

95, 98 FACES OF PISTON #95 AND RAM #98 ARE TO BE FREE OF GREASE.

