



SERVICE PARTS LIST

BUL. 54-24-3509

ROTARY HAMMER

REVISED BUL.
54-24-3508

DATE
Jan '79

Catalog No. 5300

Starting
Serial No. 342-90400

WIRING INSTRUCTIONS
58-01-0511

Specify Catalog and Serial No. when ordering parts

10AMPS

FIG.	PART NO.	DESCRIPTION OF PART	NO. REQ.	FIG.	PART NO.	DESCRIPTION OF PART	NO. REQ.
1	31-44-0460	Right Handle Half	(1)	64	02-50-3230	Needle Bearing	(1)
2	06-81-4230	1/4-20x78 Pan Hd. Mach. Screw	(8)	65	06-97-4050	1/4 Lock Washer	(2)
3	43-84-0440	Pipe Handle Insert	(1)	66	06-75-3175	1/4-20x1-1/8 Skt. Hd. Screw	(2)
4	44-52-0150	Switch Mounting Pad	(1)	67	06-75-3050	1/4-20x3/4 Skt. Hd. Screw	(2)
5	06-65-1570	Roll Pin	(2)	68	06-97-4050	1/4 Lock Washer	(2)
6	44-52-0160	Switch Mounting Pad	(1)	69	28-02-0321	Side Handle Adapter	(1)
7	23-66-0506	Switch	(1)	70	28-14-1175	Gear Case	(1)
8	31-44-0470	Left Handle Half	(1)	71	42-50-0095	Shift Cam	(1)
9	06-55-1525	1/4-20 Hex Nut	(4)	72	34-40-1150	O-Ring	(1)
10	06-75-3620	1/4-20x4-1/2 Skt. Hd. Screw	(2)	73	34-80-1500	Retaining Ring	(1)
11	06-97-4050	1/4 Lock Washer	(2)	74	02-04-2535	Ball Bearing	(1)
12	06-55-3700	3/4-16 Hex Nut	(1)	75	34-60-1875	Retaining Ring	(1)
13	06-97-4350	13/16 Lock Washer	(1)	76	45-06-0201	Felt Spindle Seal (Two Halves)	(1)
14	06-81-8650	6-32x1/4 Rd. Hd. Sem	(4)	77	30-16-6055	Nose Cap	(1)
★15	44-66-5340	Cover Plate	(1)	78	06-57-5150	3/8-16 Lock Nut	(2)
16	06-83-2670	1/4-20x1/2 K.nrl. Set Screw	(2)	79	40-50-6402	Tool Retaining Spring	(2)
17	22-64-0080	Cord Set	(1)	80	06-75-3350	1/4-20x2 Skt. Hd. Screw	(2)
18	23-44-0100	Brush Retaining Screw	(2)	81	42-36-0750	Tool Retainer Bracket	(2)
19	43-44-0180	Brush Cap Gasket	(2)	82	44-86-0261	Tool Retainer	(1)
20	23-86-0075	Insulating Washer	(2)	83	45-88-0601	Washer	(2)
★21	22-22-1210	Brush Holder Assembly	(2)	84	44-66-0531	Tool Retainer Plate	(1)
22	22-18-0330	Carbon Brush Assembly	(2)	85	06-75-0600	3/8-16x1-3/4 Hex Hd. Screw	(2)
23	45-88-0490	Commutator End Washer (Neoprene)	(1)	86	44-66-0580	Tool Adapter Plate	(1)
24	45-88-5402	Flat Washer (Steel)	(1)	87	06-57-5000	1/4-20 Lock Nut	(2)
25	02-04-0970	Ball Bearing	(1)	88	43-76-0370	Depth Gauge Housing	(1)
★26	18-62-1105	120 Volt Field	(1)	89	06-75-2950	1/4-20x1/2 Skt. Hd. Screw	(1)
27	42-68-0360	Field Mounting Clamp	(2)	90	42-36-0970	Depth Gauge Bracket	(1)
28	45-88-5220	Washer	(2)	91	06-97-4050	1/4 Lock Washer	(3)
29	06-75-3175	1/4-20x1-1/8 Skt. Hd. Screw	(2)	92	06-75-3175	1/4-20x1-1/8 Skt. Hd. Screw	(3)
★30	16-62-1135	120 Volt Armature (Include Fig. Nos. 31 & 32)	(1)	93	06-97-4200	1/2" Lock Washer	(1)
31	34-60-1400	Snap Ring	(1)	94	06-55-3100	1/2-20 Hex Nut	(1)
32	22-84-0360	L. H. Fan Assembly	(1)	95	44-94-0230	Depth Gauge Rod	(1)
33	02-04-1640	Ball Bearing	(1)	96	02-50-7810	Needle Bearing	(1)
34	45-88-5405	Flat Washer (Steel)	(1)	97	32-75-2630	Spindle Gear	(1)
35	45-88-0500	Pinion End Washer (Neoprene)	(1)	98	45-06-0121	Spindle Seal	(1)
36	28-50-6075	Motor Housing (Includes Fig. Nos. 37 & 38)	(1)	99	34-40-1120	O-Ring	(2)
37	06-65-0630	3/16x1/2 Drivlok Pin	(1)	100	40-50-6403	Spindle Seal Spring	(1)
38	45-30-0110	Ball Bearing Retaining Slug	(1)	101	34-80-1000	Retaining Ring	(2)
39	45-58-0180	Spring Housing Stud	(1)	102	42-40-0370	Spindle Gear Bushing	(1)
40	44-86-0151	Ram Retainer	(1)	103	02-50-2423	Needle Bearing	(1)
41	40-50-6100	Ram Disc Spring	(6)	104	36-14-0051	Clutch Shaft	(1)
42	45-88-5415	Flat Washer	(1)	105	32-44-1301	Intermediate Gear	(1)
43	43-76-0202	Spring Housing Assembly (Includes Fig. No. 44)	(1)	106	45-88-0470	Clutch Washer	(1)
44	42-40-0272	Bushing	(1)	107	32-60-1030	Pinion Gear	(1)
45	34-40-2200	O-Ring	(1)	108	45-88-0480	Clutch Washer	(1)
46	45-88-5417	Flat Washer	(3)	109	45-88-5250	Flat Keyed Washer	(1)
47	02-80-1700	Thrust Bearing	(1)	110	34-80-1510	Retaining Ring	(1)
48	40-50-6000	Ram Spring	(1)	111	02-04-1015	Ball Bearing	(1)
49	44-82-0061	Ram	(1)	112	40-50-6200	Clutch Disc Spring	(4)
50	28-28-1401	Diaphragm (Incl. Fig. Nos. 51 & 52)	(1)	113	45-88-5255	Flat Washer	(1)
51	45-30-0110	Ball Bearing Retaining Slug	(1)	114	06-57-5200	3/8-24 L.H. Lock Nut	(1)
52	06-65-0630	3/16x1/2 Drivlok Pin	(1)	115	28-20-1101	Gear Case Cover (Includes Fig. Nos. 116 & 117)	(1)
53	06-97-4050	1/4 Lock Washer	(2)	116	12-98-6510	Instruction Plate	(1)
54	06-75-3350	1/4-20x2 Skt. Hd. Screw	(2)	117	06-81-8200	4-36x3/16 Rd. Hd. Sem	(2)
55	43-06-0110	Disc	(1)	118	06-97-4050	1/4 Lock Washer	(4)
56	02-50-4015	Needle Bearing	(1)	119	06-75-3050	1/4-20x3/4 Skt. Hd. Screw	(4)
57	02-50-4020	Needle Bearing	(1)	120	43-62-0230	Pipe Handle	(1)
58	40-50-6401	Cam Shaft Spring	(1)	121	43-62-0245	Handle Grip	(1)
59	02-02-0340	11/32 Steel Ball	(2)	122	45-96-0080	Clutch Adjusting Wrench (Not Shown)	(1)
60	42-50-0071	Cam	(1)	123	49-96-0085	3/16 Hex Key (Not Shown)	(1)
61	32-42-1310	First Intermediate Gear	(1)	★124	10-98-5985	Caution Label (not shown)	(1)
62	06-42-1200	Woodruff Key	(2)	125	06-81-8625	6-32x1/4 Ground Screw (Not Shown)	(1)
63	36-10-0701	Cam Shaft	(1)	★126	12-99-0011	Nameplate Blank (not shown)	(1)
				★127	06-85-0200	Nameplate Screw (not shown)	(2)

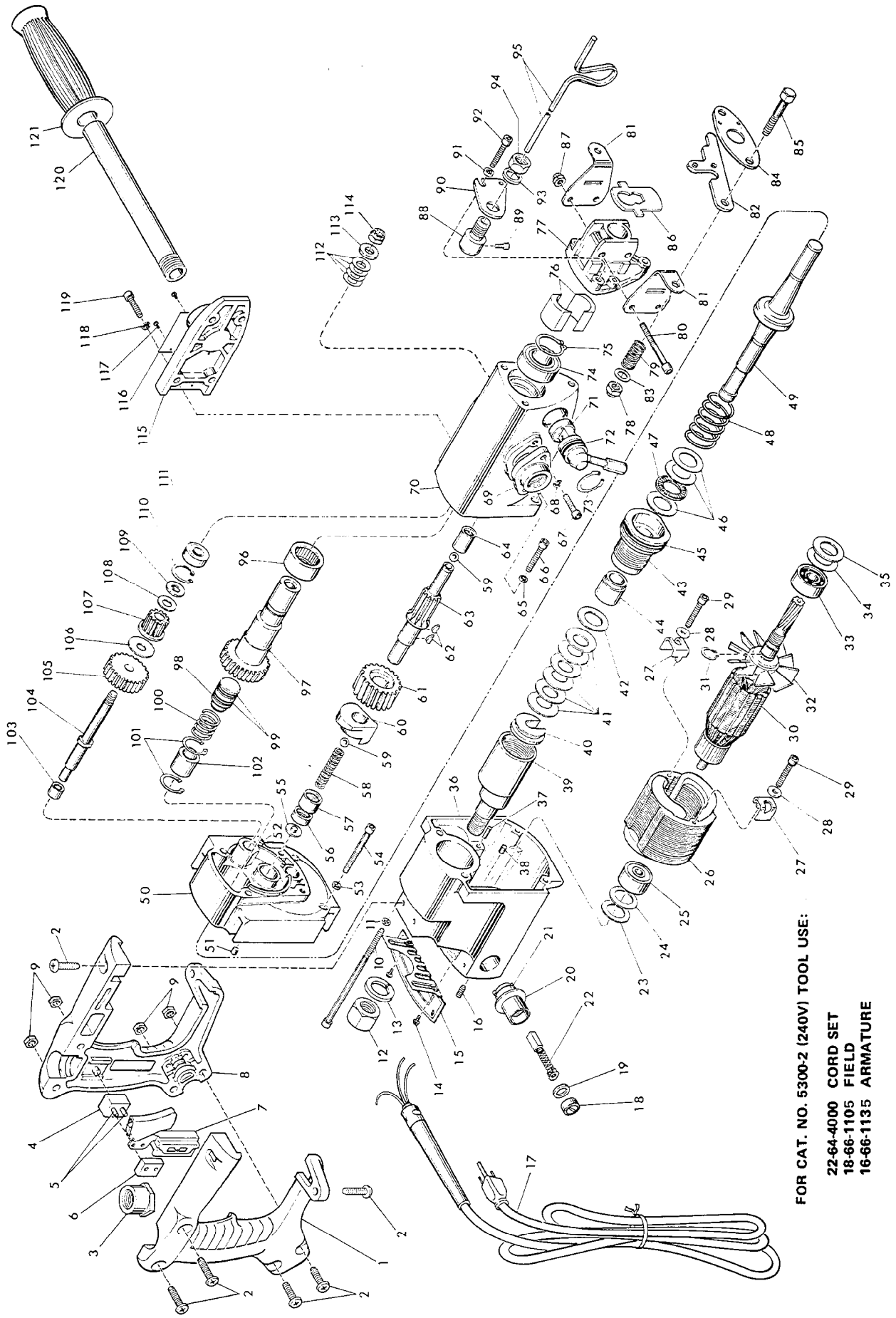

FOR CAT. NO. 5300-2 (240V) TOOL USE:

22-64-4000 CORD SET

18-66-1105 FIELD

16-66-1135 ARMATURE