



# SERVICE PARTS LIST

BUL. 54-22-9027

6" GRINDER

REVISED BUL. 6155-8 DATE FEB. '68

Catalog No. 5240-8

Starting Serial No. 155-4105

WIRING INSTR.

Both Model and Serial No. must be furnished to obtain correct parts.

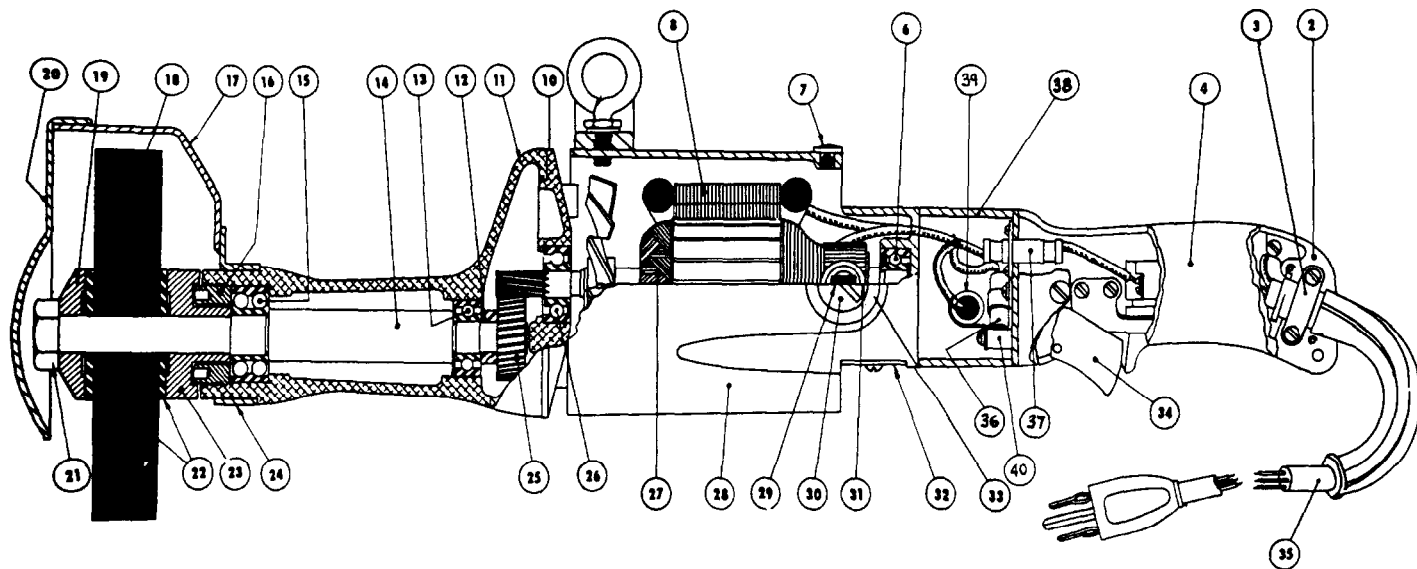

### ILLUSTRATED PARTS

FIG.	PART NO.	DESCRIPTION OF PART	FIG.	PART NO.	DESCRIPTION OF PART
2	28-44-1041	Handle (Switch Mounting Side)	23	43-34-0070	Inner Wheel Flange
3	28-17-0200	Cord Clamp Strap	24		Sold only as an Assembly
4	28-44-9081	Handle (Switch Cover Side)	25	32-75-2281	Spindle Gear
6	02-04-1070	Ball Bearing (Comm. End)	26	02-04-1140	Ball Bearing (Pinion End)
7	06-77-1400	Drive Screw Tool Rest Button	27	16-82-1460	Armature Assembly
8	18-82-1170	Field Assembly	28	14-38-0260	Eyebolt, Tool Rest, Motor Housing Assy.
10	28-28-1021	Diaphragm	29	22-18-0260	Carbon Brush Assemblies (2 per set)
11	28-50-7601	Spindle Housing	30	23-44-0065	Brush Ret. Cap Assy. (2per set)
12	45-36-0220	Spindle Gear Spacer	31	22-22-0130	Brush Holder Assembly (2)
13	02-04-1520	Ball Bearing (Inner)	32	44-66-0100	Commutator Cover Plate
14	38-50-3901	Spindle	33	22-24-0100	Brush Holder Bushing Steel (2)
15	02-20-1720	Ball Bearing (outer)	34	23-66-0250	Switch Assembly
16	44-40-0180	Bearing Lock Nut	35	22-64-0160	Cord Set
17	43-54-0120	6" Guard Assembly	36	22-23-3460	R.H. Condenser (.1 MFD)
18	49-92-3240	6x1x5/8 Hole Grinding Wheel (24 Grit)		22-33-3450	L.H. Condenser (.1 MFD)
19	43-34-0060	Outer Wheel Flange	37	22-33-6450	.01 MFD Condenser (2)
20		Sold only as an Assembly	38	28-50-8123	Radio Suppression Box
21	06-55-3250	5/8-11 Spindle Nut	39	22-33-4000	.22 MFD Condenser
22	45-88-0260	Rubber Flange Washers	40	45-36-0190	Spacer

### MISCELLANEOUS PARTS NOT SHOWN

PART NO.	DESCRIPTION OF PART	PART NO.	DESCRIPTION OF PART
12-98-3500	Name Plate (DWG No. 8)	06-97-2400	Lockwasher (4)
23-86-0130	Insulating Washers	06-81-8650	6-32x1/4 Rd.Hd. Condenser Mounting (6)
06-81-6100	No. 8-32x7/16 Fil.Hd. Cord Clamp Strap Sems (2)	06-81-8625	No. 6-32x1/4 Rd.Hd. Ground Wire Screw (Brass) (2)
06-81-7150	No. 10-24x1-3/8 Fil.Hd. Spindle Housing Screws (4)	06-81-5400	No. 8-32x5/16 Binder H.D. Switch Mtg. Sc. (2)
06-81-3750	No. 8-32x1 Oval Hd. Handle Cover Screw	06-81-8200	No. 4-36x3/16 Rd.Hd. Name Plate Sems (2)
06-81-3700	No. 8-32x7/8 Oval Hd. Handle Cover Screw (2)	06-81-8650	No. 6-32x1/4 Rd.Hd. Comm. Cover Plate Sc. (2)
06-81-8950	No. 8-32x2-1/4 Rd.Hd. Field Screws (2)	06-81-6950	No. 10-24x1/2 Fil.Hd. Tool Rest Sem (2)
06-83-2650	1/4-20x3/8 Hd'less Brush Holder Set Screws (2)	06-97-3200	No. 8 Kantlink Lockwasher
06-81-1625	No. 12-24x2-1/4 Fil.Hd. Switch Handle Screws (4)	06-97-3400	No. 10 Kantlink Lockwasher
06-77-0450	4x1/4 Rd.Hd. Driv-in Screw (2)		
06-97-1800	Shakeproof Washer (6)	12-98-5199	Warning Plate
06-81-0650	6-32x5/8 Fil.Hd. Condenser Mtg. Screw	23-16-0270	Insulator (2)