



SERVICE PARTS LIST

BULLETIN NO.
54-22-1002

SPECIFY CATALOG NO. AND SERIAL NO. WHEN ORDERING PARTS		REVISED BULLETIN 54-22-1001	DATE SEPT. '80
DIE GRINDER			
CATALOG NO. 5195	STARTING SERIAL NO. 525-10500	WIRING INSTRUCTION 58-01-0506	

14,500 R.P.M.
9 AMPS

FOR CAT. NO. 5195-2(240V) TOOL USE:

16-66-1202 ARMATURE
18-66-1037 FIELD
22-64-4000 CORD SET

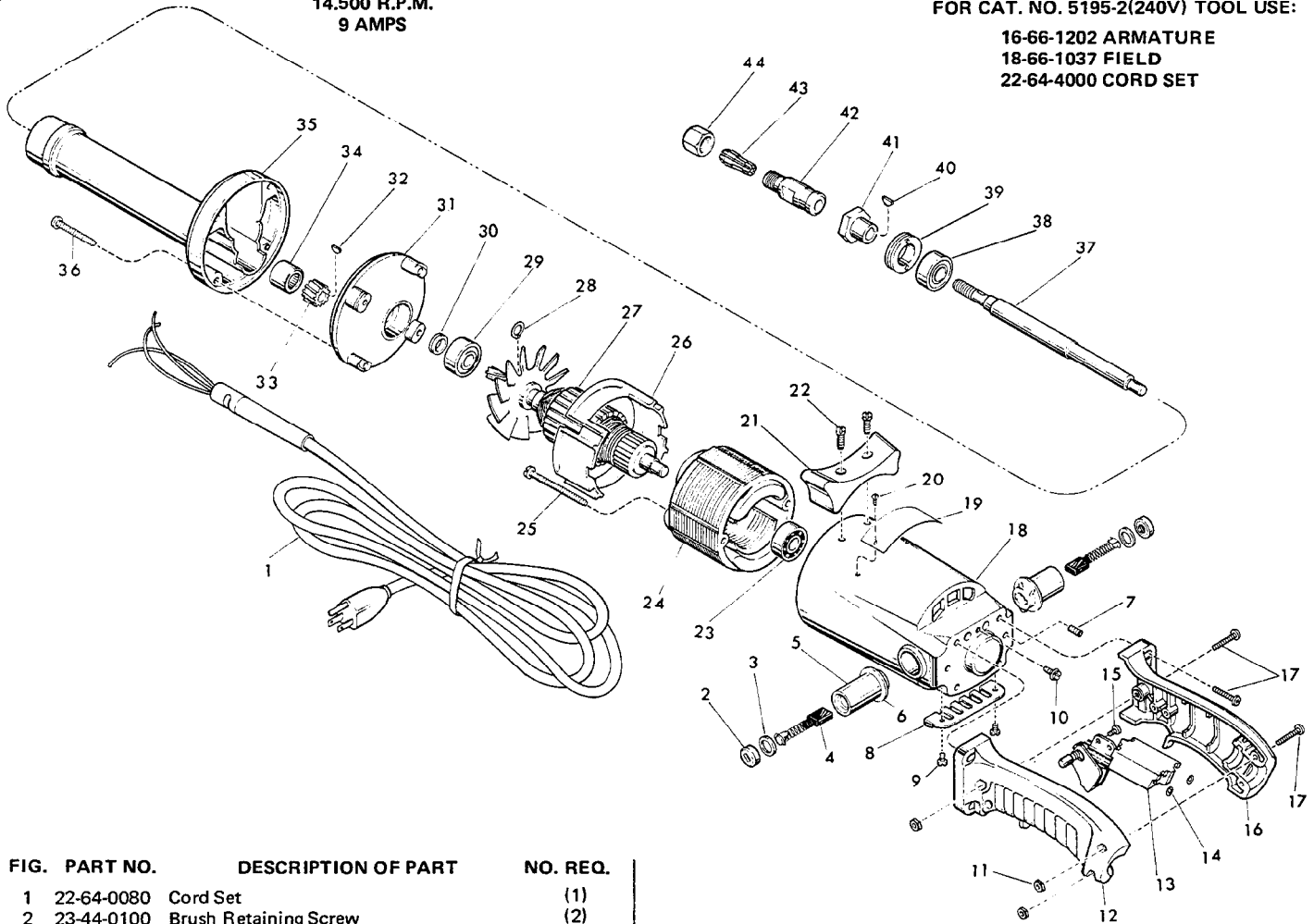

FIG.	PART NO.	DESCRIPTION OF PART	NO. REQ.
1	22-64-0080	Cord Set	(1)
2	23-44-0100	Brush Retaining Screw	(2)
3	43-44-0180	Brush Cap Gasket	(2)
4	22-18-0175	Carbon Brush Assembly	(2)
5	22-22-1231	Brush Holder Assembly	(2)
6	23-86-0075	Insulating Washer	(2)
7	06-83-2000	10-24x1/4 Set Screw	(2)
8	44-66-0230	Commutator Cover Plate	(1)
9	06-81-8650	6-32x1/4 Rd. Hd. Sem	(2)
10	06-81-8800	8-32x1/4" Rd. Hd. Sem	(1)
11	06-55-1000	10-24 Hex Nut	(3)
12	31-44-0590	Left Handle Half	(1)
13	23-66-0255	Switch	(1)
14	06-97-1800	Lock Washer	(4)
15	06-95-0215	8-18x1/2 Pan Hd. Thread Form Screw	(1)
16	31-44-0580	Right Handle Half	(1)
17	06-81-4207	10-24x7/8 Phillips Pan Hd. Screw	(7)
18	28-50-5101	Motor Housing	(1)
19	12-99-0032	Nameplate Blank	(1)
20	06-85-0200	Nameplate Screw	(2)
21	28-79-0321	Tool Rest	(1)
22	06-81-6950	10-24x1/2 Fil. Hd. Sem	(2)
23	02-04-0970	Ball Bearing	(1)
24	18-62-1037	120V Field	(1)
25	06-81-8950	8-32x2-1/4 Rd. Hd. Sem	(2)
26	31-05-0100	Baffle	(1)
27	16-62-1202	120V Armature (Includes Fig. No. 28)	(1)
28	34-60-0900	Retaining Ring	(1)

FIG.	PART NO.	DESCRIPTION OF PART	NO. REQ.
29	02-04-1270	Ball Bearing	(1)
30	45-28-0060	Grease Slinger	(1)
31	28-28-0981	Diaphragm	(1)
32	06-42-0450	Key No. 202.5	(1)
33	32-40-1750	Spindle Gear	(1)
34	02-50-3200	Needle Bearing	(1)
35	28-50-7701	Spindle Housing	(1)
36	06-81-7150	10-24x1-3/8 Fil. Hd. Sem	(4)
37	38-50-5100	Spindle Shaft	(1)
38	02-04-1200	Ball Bearing	(1)
39	44-40-0410	Bearing Lock Nut - L.H. Thread	(1)
40	06-42-0400	Key No. 202	(1)
41	43-34-0170	Collet Flange	(1)
★42	42-77-0080	Collet Body	(1)
★43	43-66-0975	1/4" Dia. Collet	(1)
★44	44-40-0435	Collet Nut	(1)
45	12-98-7066	Caution Plate (Not Shown)	(1)
46	49-96-4040	1/2" Open End Wrench (Not Shown)	(1)
★47	49-96-4090	11/16" Open End Wrench (Not Shown)	(1)
48	49-96-4075	1" Open End Wrench (Not Shown)	(1)
49	23-48-7378	3" Insulating Sleeve (Not Shown)	(2)