

MODEL 6512/130SQ, 500430

PARTS LEGEND

MODEL 6625/160SQ, 500440

1	500444	1	Silencer Cap	54	094742	1	Washer, .312 x.75 x.062	
2	404229	4	Socket Head Cap Screw, 1/4-20 x 2-1/4 (6512/130SQ)	55	500654	1	Piston Bumper	
	404367	4	Socket Head Cap Screw, 1/4-20 x 3-1/4 (6625/160SQ)	56	500434	2	Housing Plug, 1/2"	
3	002187	8	Lock Washer, 1/4-20	57	097748	1	Spring, Valve Pin	
4	091447	4	Flat Washer	58	097746	1	Valve Pin	
5	500487	4	Spacer, Silencer Cap	59	092174	1	O-Ring, Valve Body	
6	500416	1	Cap, Machined (6512/130SQ)	60	401958	1	Valve Body	
	500418	1	Cap, Machined (6625/160SQ)	61	500479	2	Flanged Bearing	
7	404325	4	Locknut, 8-32	62	500365	1	Rod, Work Contacting Element Actuation	
8	401955	3	Washer, 8-32	63	500445	1	Spring, Work Contacting Element Rod	
*	9	500485	1	O-Ring (-203)	→ 64	008388	1	Washer
10	500626	1	Shuttle Valve Assembly	65	500383	1	Retaining Ring	
→ 11	500946	1	Square Ring	66	500478	1	Side Handle Assembly Kit w/ tool	
12	091339	1	Spring, Shuttle Valve	67	095412	1	Washer, .376 I.D.	
13	009016	3	Socket Head Cap Screw, 5/16 x 1	68	500350	1	Magazine (6512/130SQ)	
14	095417	2	Lock Washer, 5/16		500351	1	Magazine (6625/160SQ)	
15	500443	1	Hanging Bracket	* 69	500520	2	Wear Strip	
16	500387	1	Cap Plug, 1/8 NPT	70	500633	1	Nail Cover	
17	500407	1	Main Valve Spring	71	404325	1	Lock Nut, 8-32	
18	500371	1	Retaining Ring	72	500632	1	End Cap, Magazine	
* 19	402961	1	O-Ring (-233)	73	500384	3	Socket Head Cap Screw, 8-32 x 1.25	
20	500340	1	Upper Valve Piston	74	500489	1	Button Head Cap Screw, 5/16-24 x 1.25	
21	500339	1	Seal, Main Valve	75	500441	2	Grip, Magazine	
* 22	401951	1	O-Ring (-126)	76	500435	2	Bushing, Grip	
* 23	091208	1	O-Ring (-032)	** 77	500446	2	Label, Danger	
* 24	500367	1	O-Ring (-035)	78	095411	4	Cap Screw, 1/4-20	
25	500341	1	Lower Valve Piston	79	500386	4	Bushing, Magazine	
26	500360	1	Post	80	500629	1	Follower Assembly	
→ ▲ 27	500630	1	Socket Head Cap Screw, 8-32 x.813	81	091825	1	Pin, Negator	
* 28	500369	1	O-Ring (-133)	82	091826	1	Drum, Negator	
29	091861	1	Lock Nut	83	091840	1	Negator Assembly	
30	092116	2	Washer	▲ 84	009037	2	Socket Head Cap Screw, 10-32 x 1/2	
* 31	500480	1	O-Ring (4 x 60 Metric)	85	004238	2	Lock Washer, No. 10	
32	500337	1	Piston	86	402094	2	Flat Washer, No. 10	
* 33	500373	1	Driver Blade (6512/130SQ)	* 87	500363	1	Lower Work Contacting Element (6512/130SQ)	
	500374	1	Driver Blade (6625/160SQ)		500375	1	Lower Work Contacting Element (6625/160SQ)	
34	500338	1	Sleeve Seal	88	500362	1	Intermediate Work Contacting Element	
35	500336	1	Sleeve (6512/130SQ)	89	500436	1	Spring, Work Contacting Element	
	500342	1	Sleeve (6625/160SQ)	90	402095	1	Nut Bar	
→*36	095409	1	O-Ring (-038)	91	500349	1	Nosepiece (6512/130SQ)	
37	500352	1	Bumper Plate		500344	1	Nosepiece (6625/160SQ)	
* 38	500376	1	Bumper	92	500358	1	Seal, Nose	
* 39	500357	1	Gasket, Cap	93	500361	1	Pin, Lockout	
40	404938	2	Label, Upper Housing	94	500422	1	Shear Block Assembly (6512/130SQ)	
41	500786	1	Nameplate, (6512/130SQ)		500423	1	Shear Block Assembly (6625/160SQ)	
	500787	1	Nameplate, (6625/160SQ)	95	403082	2	Washer	
* 42	500486	1	O-Ring (-234)	96	402738	1	Spring, Lockout	
* 43	500368	1	O-Ring (-042)	97	500372	1	Retaining Ring	
44	500343	1	Flange	98	095417	1	Lock Washer, 5/16	
45	500590	1	Roll Pin Assembly	99	034976	1	Nut, Flexlock, 5/16	
46	500490	1	Label, Hanger Bracket	100	026133	2	Roll Pin, 1/8 x 1	
47	500380	5	Lock Washer, 3/8	101	500640	2	SHCS 6-32 x 3/8"	
48	092171	5	Socket Head Cap Screw, 3/8 x 1	102	091569	2	Flexloc Nut 6-32	
* 49	091623	1	O-Ring (-011)	103	402079	1	Pin, Trigger	
50	500378	1	Housing Assembly	104	406006	1	Sequential Trigger Assembly	
51	405539	1	Label, Nail Size (6512/130SQ)	105	500421	1	Main Valve Assembly	
	405540	1	Label, Nail Size (6625/160SQ)	106	092048	1	O-Ring	
52	500522	1	Reducing Pipe Bushing	→107	500569	1	Handle and Core	
53	500432	1	Acorn Nut, 5/16-24	→108	500628	4	Roller	
				→109	402668	2	Retainer	
				→110	402743	2	Pin	

▲ Apply Loctite (Blue), Part No. 093500

* Denotes Normal Wear Item

** Make sure Danger Label (500446) is properly affixed. Replace if necessary. The labels are available at no charge through the Service Department.

→ Denotes New Change.

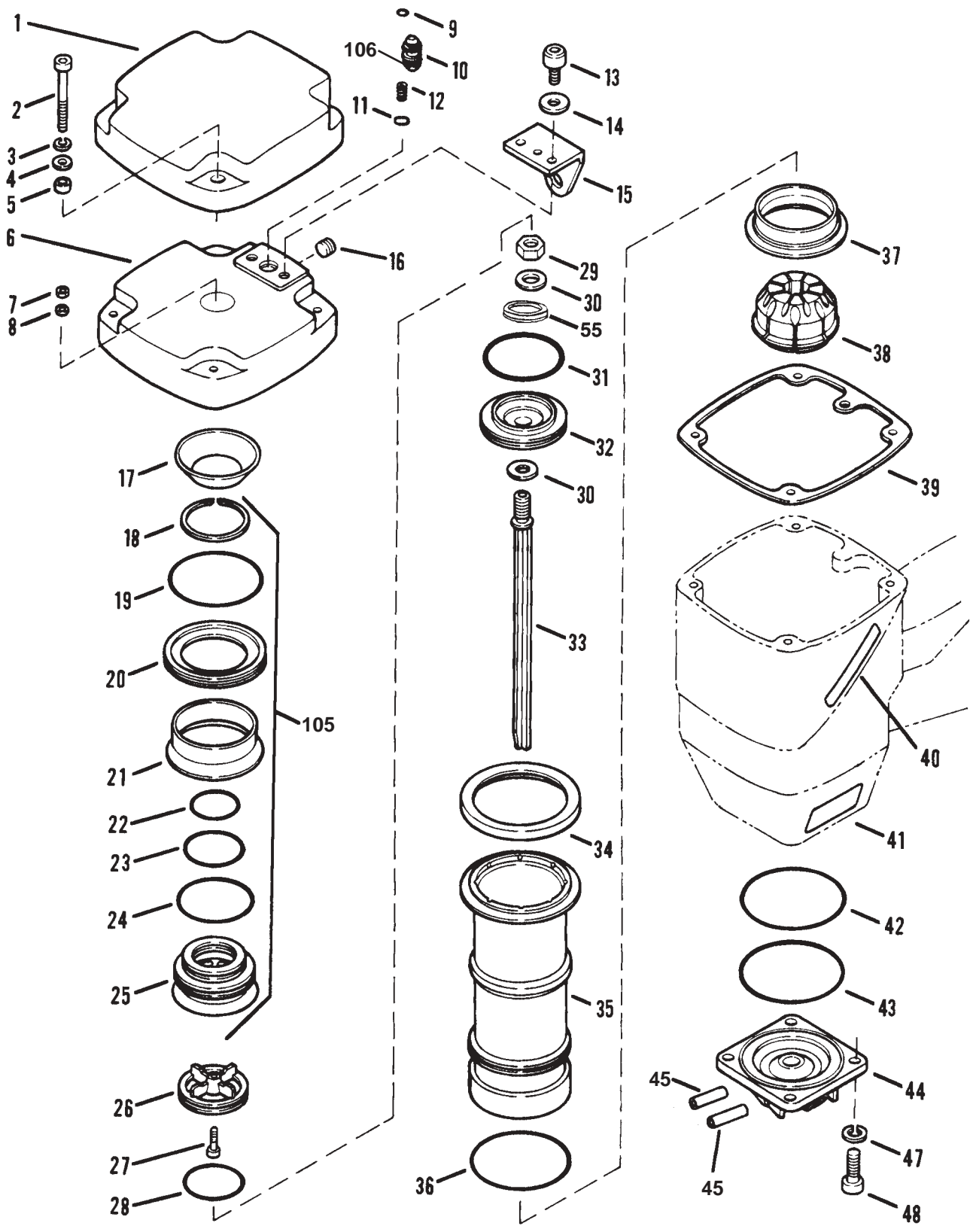

6512/130SQ

500430

6625/160SQ

500440

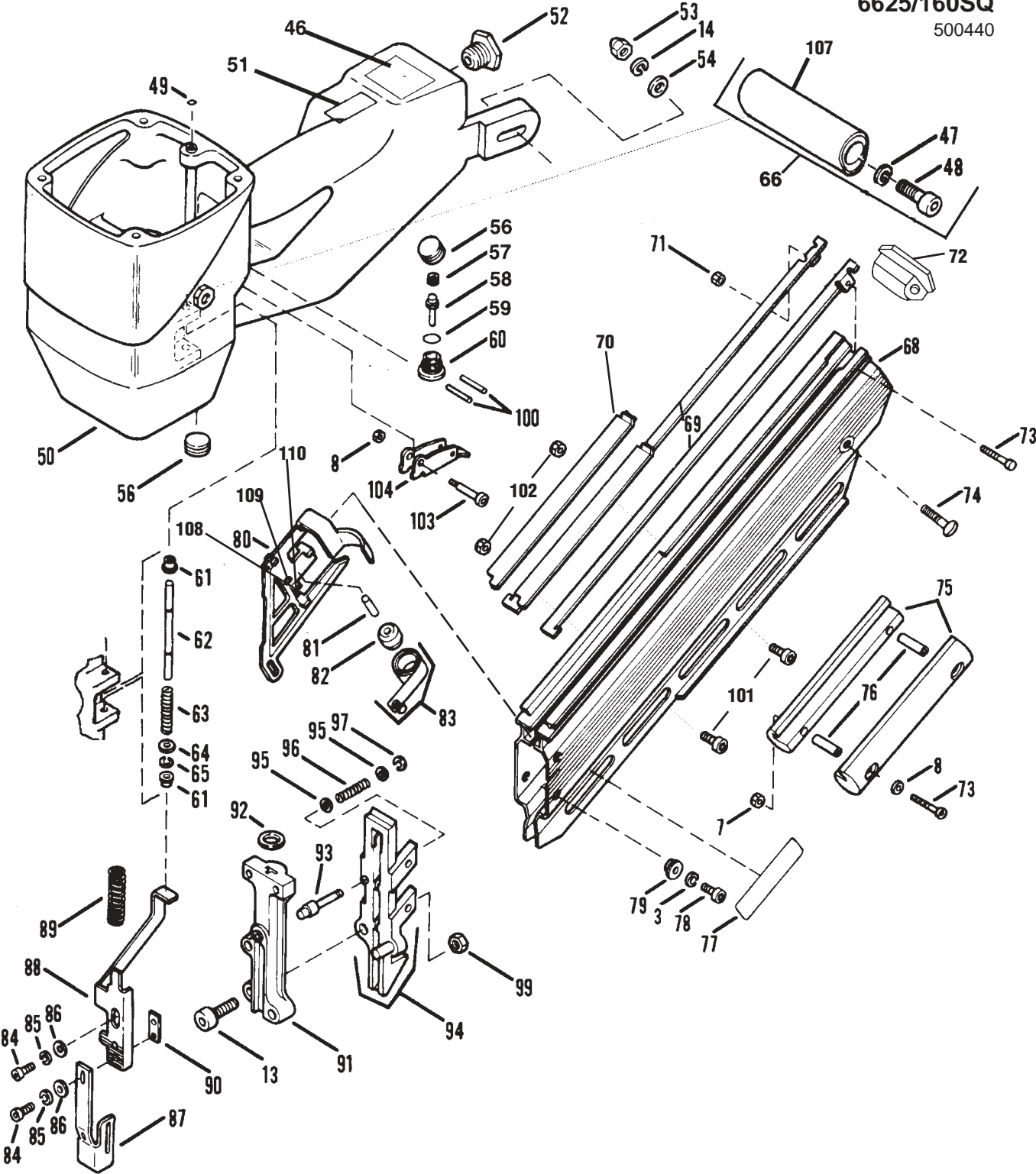

PARTS OFFERED AS ASSEMBLIES

500427 Cap Assembly (6512/130SQ) 500428 Cap Assembly (6625/160SQ)

Includes

6	500416	1	Cap
	500418	1	Cap
7	404325	1	Lockout Nut, 8-32
8	401955	1	Washer, 8-32
9	500485	1	"O" Ring
10	500626	1	Shuttle Valve Assembly
11	500946	1	Square Ring
12	091339	1	Spring Shuttle Valve
13	009016	2	Socket Head Cap Screw, 5/16 x 1
14	095417	2	Lock Washer, 5/16
15	500443	1	Hangind Bracket
16	500387	1	Cap Plug, 1/8 NPT
17	500407	1	Main Valve Spring
18	500371	1	Retaining Ring
19	402961	1	"O" Ring
20	500340	1	Upper Valve Piston
21	500339	1	Seal, Main Valve
22	401951	1	"O" Ring, Lower Valve Piston
23	091208	1	"O" Ring, Lower Valve Piston
24	500367	1	"O" Ring, Lower Valve Piston
25	500341	1	Lower Valve Piston
26	500360	1	Post
27	500630	1	Socket Head Capscrew
28	500369	1	O-Ring

500421 Main Valve Assembly

Includes

18	500371	1	Retaining Ring
19	402961	1	"O" Ring Upper Valve Piston
20	500340	1	Upper Valve Piston
21	500339	1	Seal, Main Valve
22	401951	1	"O" Ring, Lower Valve Piston
23	091208	1	"O" Ring, Lower Valve Piston
24	500367	1	"O" Ring, Lower Valve Piston
25	500341	1	Lower Valve Piston

500424 Piston Assembly (6512/130SQ) 500426 Piston Assembly (6625/160SQ)

Includes

29	091861	1	Nut
30	092116	1	Washer
31	500480	1	"O" Ring, Piston
32	500337	1	Piston
33	500373	1	Driver Blade (6512/130)
	500374	1	Driver Blade (6625/160)
55	500654	1	Piston Bumper

SAFETY INSTRUCTIONS

WEAR EYE AND HEARING PROTECTION

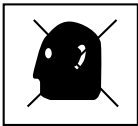

Always wear hearing protection and eye protection devices, including side shields when operating or working in the vicinity of a tool.



DO NOT EXCEED MAXIMUM RECOMMENDED AIR PRESSURE

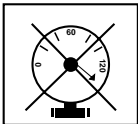

Operate the tool using only the recommended air pressure. Do not exceed the maximum air pressure marked on the tool. Be sure the air pressure gauge is operating properly and check it at least twice a day.

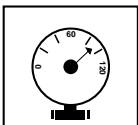

AIR CONSUMPTION CHART

