

PARTS LEGEND 3200/50-CP, 500303

1	013567	4	Socket Head Capscrew, 1-1/4 x 2-1/2"
2	002187	4	Lock Washer, 1/4"
3	404242	1	Air Diffuser
4	091447	4	Washer
▲5	006310	1	Socket Head Capscrew, #6-32 x 1/2"
→ 7	500324	1	Cap With Setscrew
8	402717	1	Conical Spring
9	404230	1	Retaining Ring
*10	091537	1	"O" Ring, Main Valve Assembly
11	404122	1	Upper Valve Piston
12	404055	1	Post, Main Valve
*13	404256	1	"O" Ring, Main Valve Post
*14	402723	1	"O" Ring, Piston
15	403582	1	Lock Nut, Gripco, 5/16-24
16	403563	1	Piston
*17	403802	1	Driver Blade - Carbide tip
	500701	1	Driver Blade (Europe only)
18	402725	1	Seal, Sleeve
19	405245	1	Sleeve
*20	402728	1	"O" Ring, Sleeve
*21	402729	1	"O" Ring, Sleeve
22	403854	1	Retaining Bumper
*23	403853	1	Bumper
*24	500325	2	Gasket, Cap
25	402701	1	Housing
26	404939	2	Logo, Housing
27	500695	1	Nameplate
28	402708	1	Gasket, Nose
29	405147	1	Lever, Trigger
30	405144	1	Trigger
31	500488	1	Grip Handle
32	005849	1	Roll Pin
33	402079	1	Pin, Trigger
34	404325	1	Stop Nut
35	026133	2	Roll Pin, 1/8" Dia. x 1" Lg.
36	404017	1	Magazine Bracket
37	004502	4	Socket Head Capscrew, #10-32 x 5/8"
38	092037	8	Flexloc Nut, #10-32
39	097748	2	Spring, Valve Pin
40	097746	1	Valve Pin
*41	092174	1	"O" Ring, Valve Body
42	401958	1	Valve Body
43	091591	1	"O" Ring, End Plug
▲44	401940	1	End Plug
45	091622	1	Reducing End Plug
46	403808	1	Nose
47	404106	1	Socket Head Capscrew, #10-32 x 2"
48	404054	1	Seal, Main Valve
▲49	091545	4	Socket Head Capscrew, 1/4 - 20 x 7/8"
50	404012	1	Holdback Claw
51	403551	1	Door
52	403558	1	Locator
53	404663	1	Spring, Work Contacting Element
*54	402031	1	"O" Ring
55	405234	1	Piston, Feed Claw
*56	092709	1	"O" Ring
57	096815	1	Spring
58	403572	1	Bumper, Feed Claw Piston
59	405233	1	Piston Guide
60	403573	1	Retaining Ring
61	402486	1	Retaining Washer
▲ 62	009037	2	Socket Head Capscrew, #10-32 x 1/2"
63	006057	2	Flat Washer, #10
*64	090927	1	"O" Ring, Main Valve
65	403807	1	Work Contacting Element
66	402488	1	Pivot Pin, Feed Claw
*67	402041	1	Torsion Spring, Feed Claw
68	403557	1	Feed Claw
69	405243	1	Flange Sleeve
**70	400658	1	Warning Label
71	404015	1	Cover, Magazine
72	402629	2	Washer
*73	403806	1	Debris Shield
74	403579	1	Roll Pin, 1/16" Dia. x 1/2" Lg.
75	403568	1	Cap, Post
76	402071	1	Extension Spring, Post
77	403543	1	Nail Plate Assembly
78	404731	1	Center Post, Outer
79	403580	1	Retaining Ring
80	403556	1	Center Post, Inner
81	005849	1	Roll Pin, 1/8" x 11/16" Lg.
82	404016	1	Magazine
83	404303	1	Socket Head Capscrew, #10-32 x 1 1/4"
84	404002	3	Grommet
85	006621	1	Socket Head Capscrew, #10 32 x 7/8"
*86	092775	1	"O" Ring, Main Valve
87	500327	1	Cap Storage
88	404361	1	Roll Pin, 1/8" x 1/2" Lg.
89	404243	4	Spacer, Diffuser
*90	092773	1	"O" Ring, Main Valve
91	404056	1	Lower Valve Piston
93	091732	1	Flexloc Nut 10-32
94	091966	1	O-Ring
95	403295	1	Spring, Compression
96	091541	1	"O" Ring, Cap
97	500328	1	"O" Ring, Cap

▲ Apply Loctite 242 (Blue) Part No. 093500

* Denotes normal wear items

** NOTE: Make sure Warning Label (400658) is properly affixed. Replace if necessary. Label available at no charge through Service Department.

→ Denotes new change.

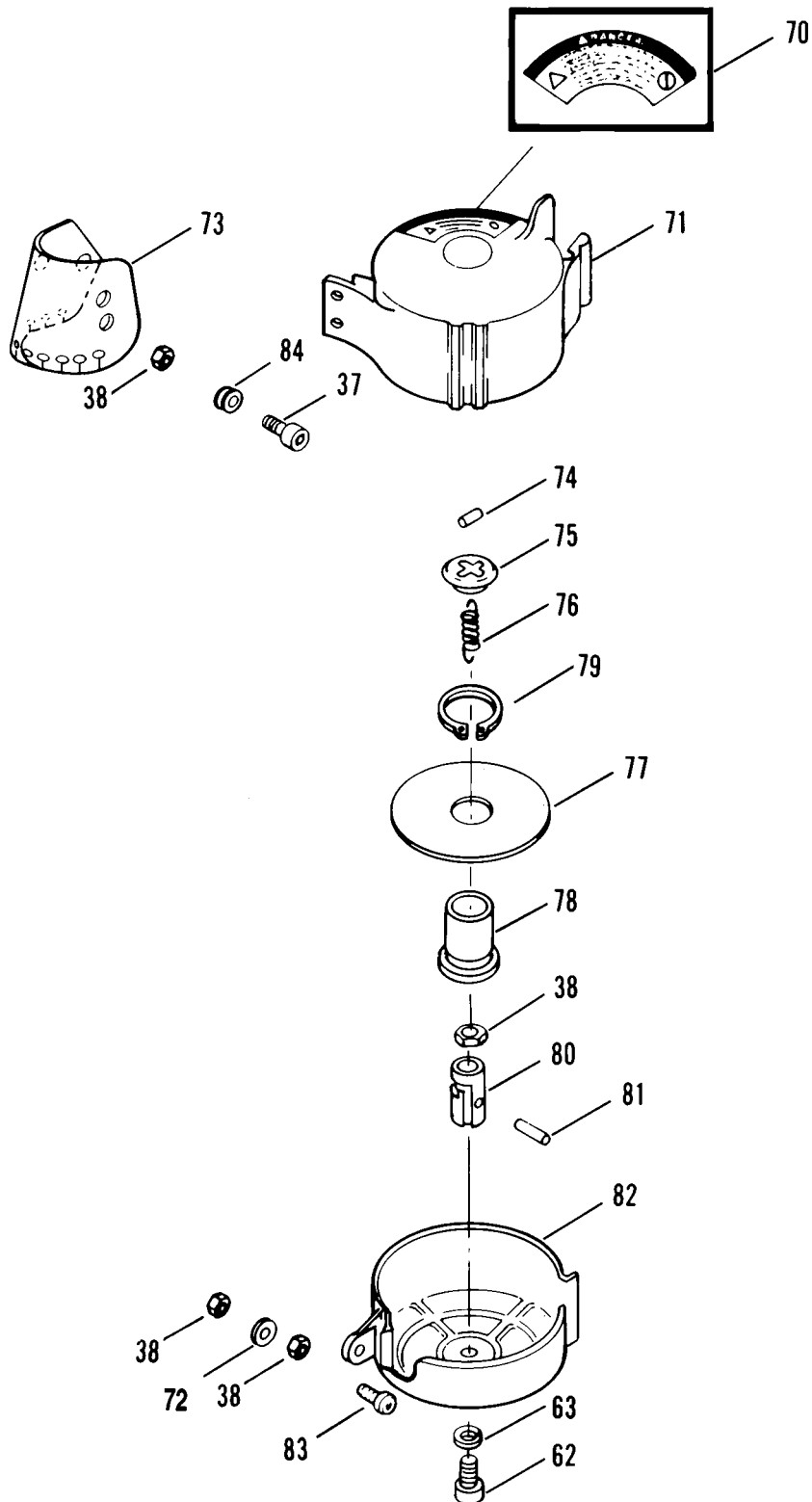

WARNING

All parts must be periodically inspected and replaced if worn or broken. Failure to do this can affect the tool's operation and present a safety hazard.

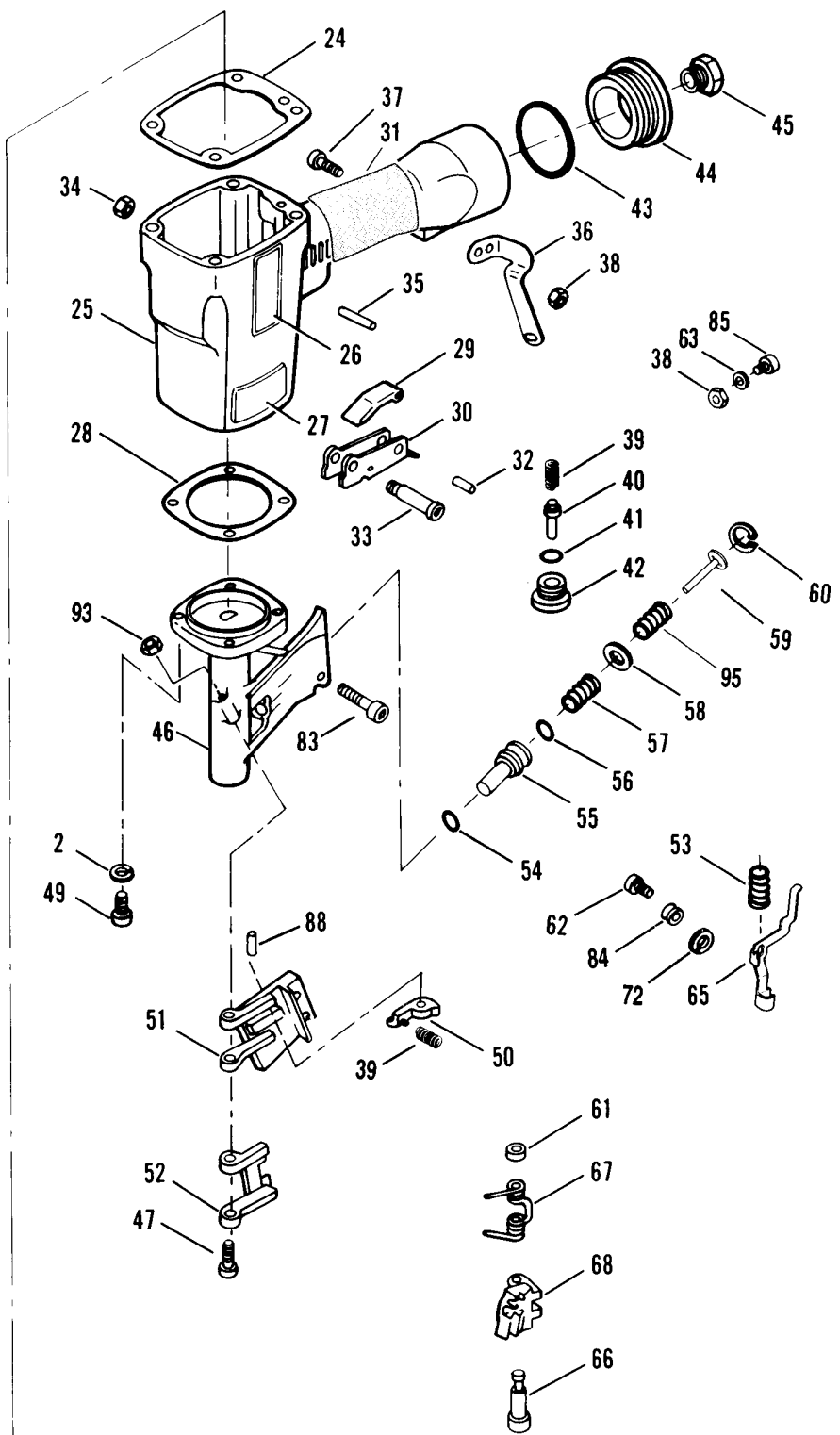
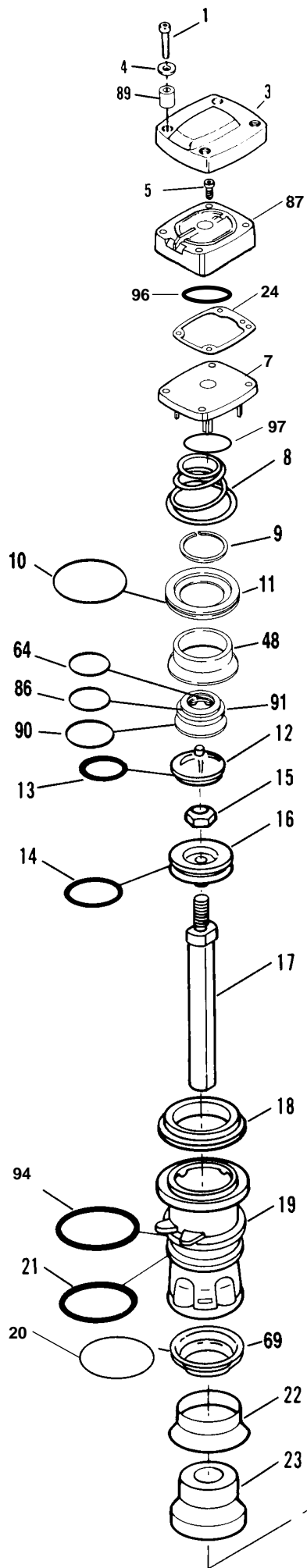

PARTS OFFERED AS ASSEMBLIES

402408 Trigger Assembly

Includes

29	405147	1	Lever, Trigger
30	405144	1	Trigger
32	005849	1	Roll Pin

404188 Main Valve Assembly

Includes

9	404230	1	Retaining Ring
*10	091537	1	"O" Ring, Main Valve Assembly
11	404122	1	Upper Valve Piston
48	404054	1	Seal, Main Valve
*64	090927	1	"O" Ring, Main Valve Assembly
*86	092775	1	"O" Ring, Main Valve Assembly
*90	092773	1	"O" Ring, Main Valve Assembly
91	404056	1	Lower Valve Piston

403804 Piston Assembly



500702 Piston Assembly (Europe Only)

Includes

*14	402723	1	"O" Ring, Piston
15	403582	1	Lock Nut, Gripco, 5/16-24
16	403563	1	Piston
*17	403802	1	Driver Blade
	500701	1	Driver Blade (Europe only)

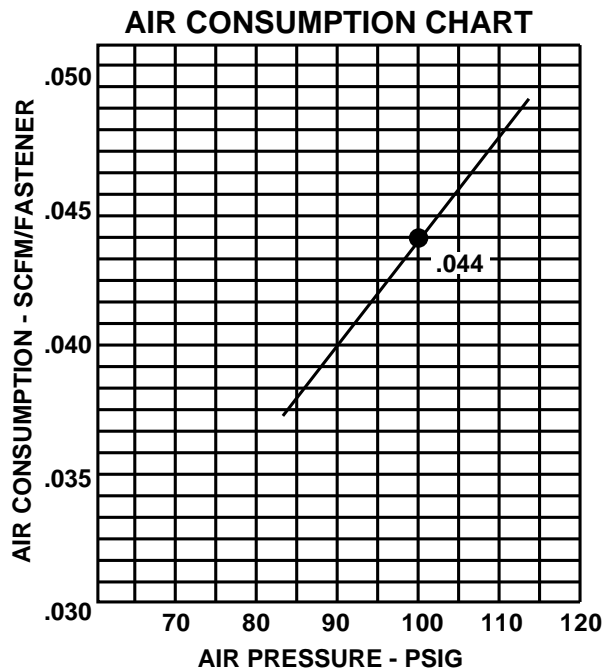

SAFETY INSTRUCTIONS

WEAR EYE AND HEARING PROTECTION



Always wear hearing protection and eye protection devices, including side shields when operating or working in the vicinity of a tool.



DO NOT EXCEED MAXIMUM RECOMMENDED AIR PRESSURE

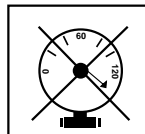

Operate the tool using only the recommended air pressure. Do not exceed the maximum air pressure marked on the tool. Be sure the air pressure gauge is operating properly and check it at least twice a day.

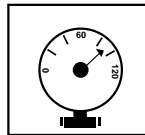

Never use any bottled air or gases such as oxygen to operate the tool since they could cause the tool to explode.