



SERVICE PARTS LIST

BULLETIN NO.
54-49-0160

SPECIFY CATALOG NO. AND SERIAL NO. WHEN ORDERING PARTS		REVISED BULLETIN	DATE
JOB SITE RADIO			Feb. 2003
CATALOG NO. 49-24-0200	STARTING SERIAL NO. 414A	WIRING INSTRUCTION 58-01-0160	

EXAMPLE:
Component Parts (Small #) Are Included
When Ordering The Assembly (Large #).

**BEFORE SERVICING,
SEE THE BACK PAGE OF THIS
BULLETIN FOR SERVICE NOTES**

FIG.	PART NO.	DESCRIPTION OF PART
1	12-20-3370	Service Nameplate Kit
2	22-09-1575	LCD PCB Assembly
7	22-64-0980	Cord
10	23-66-0740	Volume Control Switch
13	31-06-0130	Base
18	31-10-0370	LH Handle Support Mount
19	31-10-0375	RH Handle Support Mount
22	31-15-0725	LCD PCB Cover
23	31-15-2080	Battery Door
24	31-17-0420	Cord Wrap clamp
25	31-50-0835	LCD Housing Assembly
33	31-58-0610	Handle Cushion Ring
34	31-86-0250	Cord Wrap Washer
35	34-80-2025	Tube Stopper
38	42-09-1005	FM Antenna Assembly
42	42-38-0270	Cord Wrap Bumper - Right
43	42-38-0275	Cord Wrap Bumper - Left
44	42-42-0500	Tuner Button Assembly

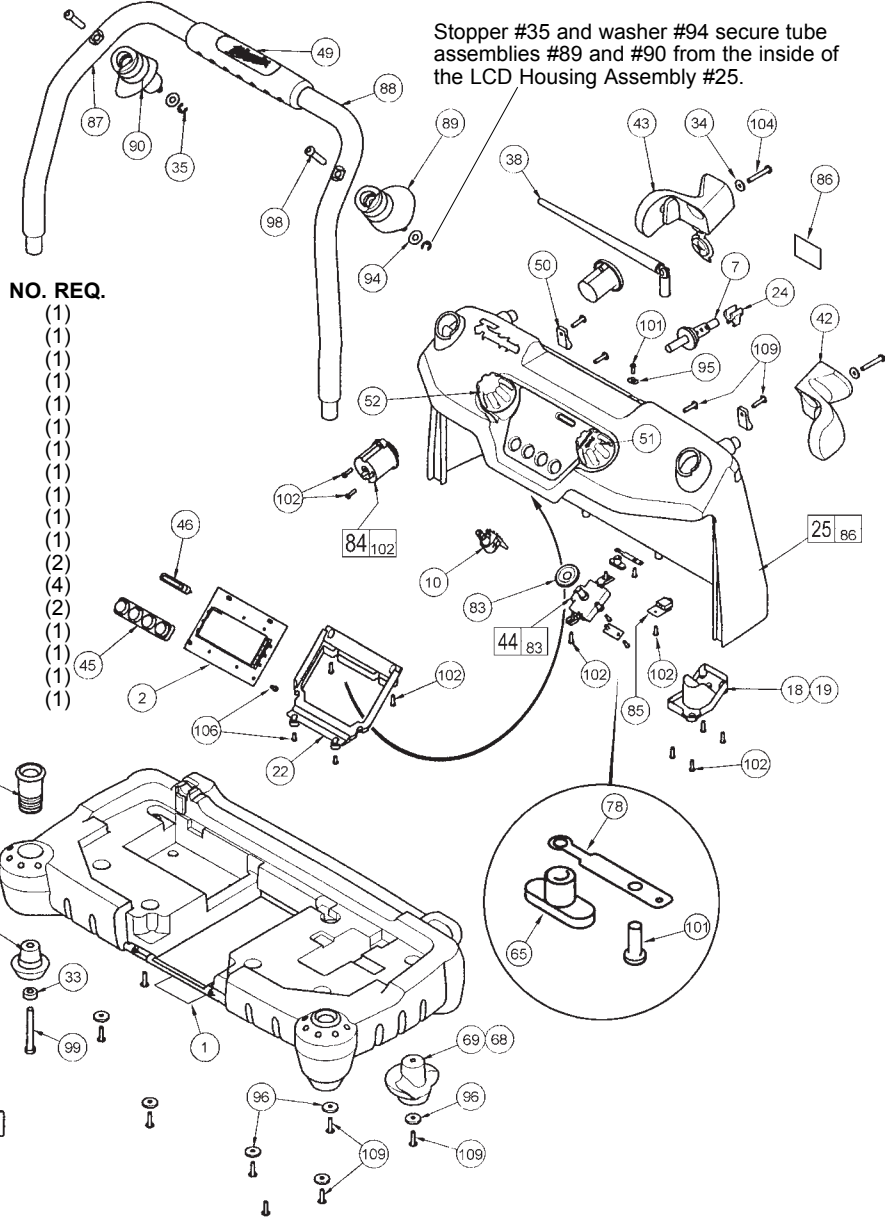

Stopper #35 and washer #94 secure tube assemblies #89 and #90 from the inside of the LCD Housing Assembly #25.

FIG.	PART NO.	DESCRIPTION OF PART	NO. REQ.
45	42-42-0520	4 Button Pad	(1)
46	42-42-0530	Button Pad - Clock	(1)
47	42-82-0100	Handle Cushion	(2)
49	43-62-1325	Handle Grip	(1)
50	43-74-0275	Back Bag Clip	(2)
51	43-98-0540	Tuner Knob	(1)
52	43-98-0545	Volume Knob	(1)
59	44-20-1075	Battery Door Latch Assembly	(1)
65	44-34-0290	FM Antenna Screw Mount	(1)
68	44-52-0765	Back Mounting Pad - Left	(1)
69	44-52-0770	Back Mounting Pad - Right	(1)
70	44-52-0780	Front Mounting Pad	(2)
75	-----	Battery Door Hinge	(2)
76	44-60-1365	Battery Door Lock Latch	(1)
78	44-66-1050	FM Antenna Plate	(1)
79	44-86-0290	Battery Door Spring Plate	(1)
81	45-06-0780	Door Seal	(1)
83	45-06-0850	Tuner Switch Seal	(1)
84	-----	12 Volt Socket Assembly	(1)
85	45-34-0160	Aux. Socket	(1)
86	45-56-3000	Hook and Loop	(1)
87	45-60-0630	Metal Handle LH Assembly	(1)

FIG.	PART NO.	DESCRIPTION OF PART	NO. REQ.
88	45-60-0635	Metal Handle RH Assembly	(1)
89	45-76-0440	Tube Assembly - Right	(1)
90	45-76-0445	Tube Assembly - Left	(1)
94	45-88-0980	Tube Washer	(2)
95	45-88-1600	Wire Washer	(1)
96	45-88-1625	Base Ring	(7)
97	05-85-0025	6 x 13 Hex Screw	(8)
98	05-85-0030	M6 x 30 Hex Screw	(2)
99	05-85-0035	M6 x 50 Hex Screw	(2)
101	05-88-0625	M3 x 8 Philips Screw	(4)
102	05-88-0660	3 x 10 Philips Screw	(31)
104	05-88-0680	4.0 x 28 Hex Ring Screw	(2)
106	05-88-0700	3 x 6 Philips Screw	(6)
107	05-88-0710	3 x 8 Philips Screw	(6)
109	05-88-0730	3.5 x 15 Hex Ring Screw	(17)
	42-16-0700	Tote Bag (Not Shown)	(1)

MILWAUKEE ELECTRIC TOOL CORPORATION
13135 W. LISBON RD., BROOKFIELD, WI 53005

FIG.	PART NO.	DESCRIPTION OF PART	NO. REQ.
3	14-46-1546	Speaker PCB Kit	(1)
4	-----	Transformer PCB	(1)
5	-----	Battery Contact Assembly	(1)
6	22-56-0780	Battery Connector	(1)
8	23-45-2000	5-1/4" Speaker	(2)
9	23-45-2100	Tweeter	(2)
11	23-81-0545	Transformer Assembly	(1)
12	31-01-1080	Milwaukee Logo - Molded	(1)

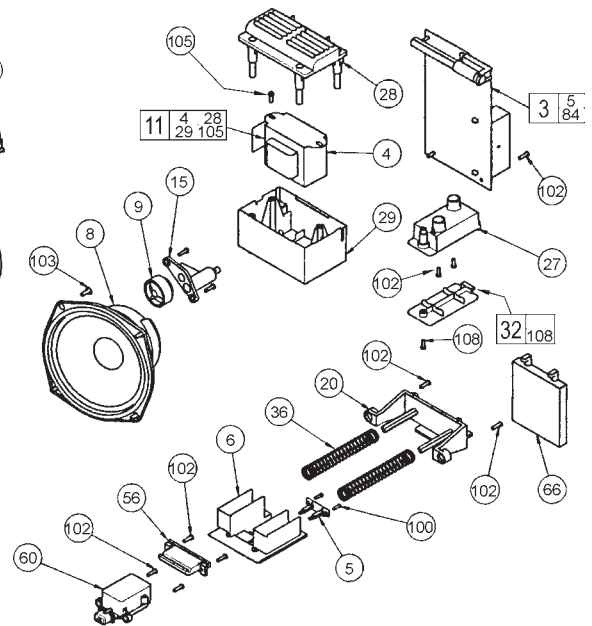
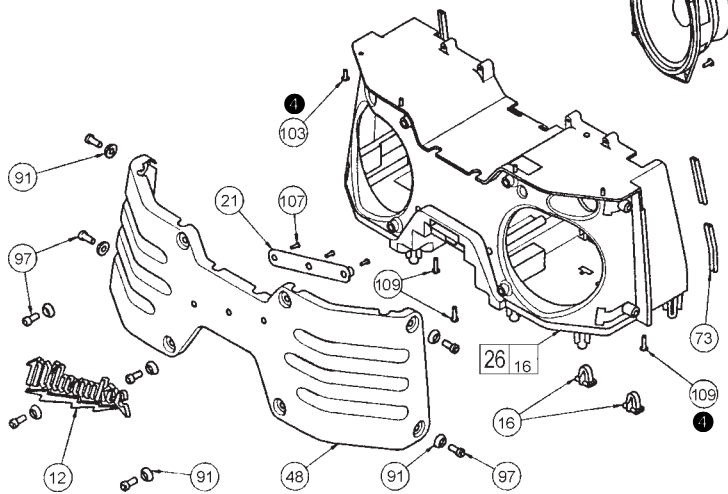

REMOVE FASTENERS IN THE ORDER THAT IS INDICATED (1, 2, 3, 4) TO SERVICE INTERNAL COMPONENTS.

FIG.	PART NO.	DESCRIPTION OF PART	NO. REQ.
14	31-10-0320	Tweeter Plate - Right	(1)
15	31-10-0325	Tweeter Plate - Left	(1)
16	31-10-0330	Speaker PCB Mount	(2)
20	31-10-0390	Battery Spring Retainer	(1)
21	31-12-0320	Logo Cap Plate	(1)
26	31-50-0996	Speaker Housing Assembly	(1)
27	31-50-1195	AA Battery Assembly	(1)
28	31-50-1560	Transformer Top Housing	(1)
29	31-50-1565	Transformer Bottom Housing	(1)
32	31-15-2095	AA Battery Lid Assembly	(1)
36	40-50-0670	Battery Cushion Spring	(2)
48	43-52-0080	Speaker Grill	(1)
56	44-20-0625	Door Lock Hinge	(1)
60	44-20-1045	Battery Lock Assembly	(1)
66	44-52-0750	Battery Cushion	(1)
73	44-52-0920	Foam Insulator	(1)
91	45-88-0880	Speaker Grill Washer	(8)
97	05-85-0025	6 x 13 Hex Screw	(8)
100	05-88-0600	2.6 x 8 Philips Screw	(2)
101	05-88-0625	M3 x 8 Philips Screw	(4)
102	05-88-0660	3 x 10 Philips Screw	(31)
103	05-88-0670	3.5 x 10 Hex Ring Screw	(12)
105	05-88-0690	3.5 x 15 Hex Ring Screw	(2)
108	05-88-0720	M3 x 8 Philips Screw	(1)
109	05-88-0730	3.5 x 15 Hex Ring Screw	(17)

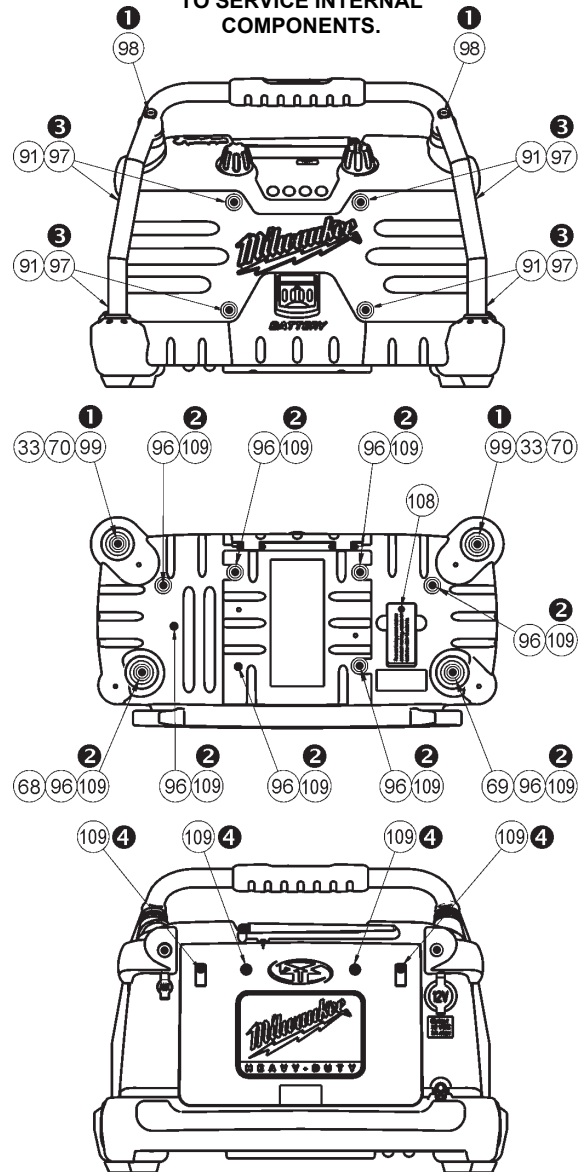

SAFETY NOTE:
Before opening the unit, disconnect all power sources (120 volt cord and/or battery pack and AA batteries) and turn on the power switch momentarily to discharge stored energy.

BASIC TROUBLESHOOTING

NOTE: Before opening the unit or soldering, disconnect ALL power sources. Turn the power switch "on" momentarily to discharge stored energy.

Radio operates on DC but not on AC:

1. Plug in radio and using a voltmeter, check for DC voltage across items #14 and #15 shown on the wiring diagram. (Approx. 15-22 Vdc).
2. If there is no voltage, change the Transformer Assembly (23-81-0545).
3. If voltage is present, continue to "All other electrical issues" shown below.

All other electrical issues

1. Disconnect the LCD Assembly (22-09-1575) from the Speaker PCB Kit (14-46-1546) by disconnecting items #11, #13 and #20 on the wiring diagram.
2. Plug a new LCD Assembly into the Speaker PCB Assembly and check for proper operation.
3. If the radio works, the LCD Assembly is bad. If the radio still does not function correctly, replace the Speaker PCB Assembly or Volume Control Switch.

NOTE: All screws should be HAND TIGHTENED. Do not over tighten screws. Over tightening screws may cause part warpage or damage.